

PAPERLESS  
CHART  
RECORDER

# OPERATING MANUAL



The default password  
for your new Paperless  
Recorder is

**123**

Version 3.0

# Table of Contents

<b>1 Introduction to Paperless Recorder .....</b>	<b>7</b>
<b>2 Instrument Description .....</b>	<b>7</b>
<b>2.1 Installation and Wiring .....</b>	<b>7</b>
<b>2.2 Unpacking.....</b>	<b>7</b>
<b>2.3 Location .....</b>	<b>7</b>
<b>2.4 Mounting.....</b>	<b>7</b>
<b>2.5 Preparation for Wiring .....</b>	<b>8</b>
2.5.1 WIRING GUIDELINES .....	8
2.5.1.1 INSTALLATION CONSIDERATIONS .....	8
2.5.1.2 AC POWER WIRING .....	9
2.5.1.3 WIRE ISOLATION/SEGREGATION .....	9
2.5.1.4 USE OF SHIELDED CABLE .....	9
2.5.1.5 NOISE SUPPRESSION AT THE SOURCE.....	10
2.5.2 SENSOR PLACEMENT (THERMOCOUPLE OR RTD) .....	11
<b>2.6 Wiring Connections .....</b>	<b>13</b>
2.6.1 AC POWER WIRING CONNECTIONS .....	14
2.6.2 Thermocouple Inputs .....	15
2.6.3 RTD Input (3-wire).....	15
2.6.4 Linear Inputs .....	15
2.6.5 OUTPUT CONNECTIONS.....	16
2.6.6 TRANSMITTER POWER SUPPLY .....	17
2.6.7 Digital Input Card Connections .....	21
2.6.8 Analog Output Card Connections .....	23
<b>2.7 Input Channels.....</b>	<b>24</b>
2.7.1 Onboard Channels.....	24
2.7.1.1 Onboard Analog Input Channels .....	24
2.7.1.2 Onboard Digital Input Channels .....	24
2.7.2 External Channels .....	25
2.7.3 Calculation Channels .....	25
<b>3 Start-up and Main Screen .....</b>	<b>26</b>
<b>3.1 Main Screen and Toolbar Overview .....</b>	<b>26</b>
<b>3.2 Login Procedure.....</b>	<b>28</b>
<b>4 Menu.....</b>	<b>33</b>
<b>4.1 Basic Configuration .....</b>	<b>33</b>
4.1.1 Authentication.....	33
4.1.1.1 Add User .....	34
4.1.1.2 View/Edit User.....	37
4.1.1.3 Enable Login.....	39
4.1.2 Communication.....	39
4.1.2.1 MODBUS Setting .....	40
4.1.2.2 Ethernet Settings .....	42
4.1.2.3 DNS Settings.....	43
4.1.2.4 FTP.....	44

4.1.2.4.1	FTP Settings .....	45
4.1.2.4.2	FTP Scheduling .....	46
4.1.2.5	Email .....	48
4.1.2.5.1	Email Settings .....	48
4.1.2.5.2	Schedule Email .....	50
4.1.2.5.3	Browser Application Permissions .....	53
4.1.3	Enable Help .....	53
4.1.4	Internal Memory Function .....	54
4.1.5	Languages .....	55
4.1.6	Temperature .....	56
4.1.7	Alarm Relays .....	57
4.1.8	Date and Time .....	59
4.1.9	Device Data .....	60
4.1.10	Memory Alarm Configuration .....	60
4.1.11	Operating Pause .....	62
4.1.12	Timer .....	63
4.1.13	Start-up Image .....	64
4.1.14	User Keys .....	64
<b>4.2</b>	<b>Channel configuration .....</b>	<b>65</b>
<b>4.3</b>	<b>Analog Output Configuration .....</b>	<b>89</b>
<b>4.4</b>	<b>Group Functions .....</b>	<b>91</b>
<b>4.5</b>	<b>Display configuration .....</b>	<b>97</b>
<b>4.6</b>	<b>Display settings .....</b>	<b>99</b>
<b>4.7</b>	<b>User Messages Entry .....</b>	<b>102</b>
<b>4.8</b>	<b>Batch Configuration .....</b>	<b>104</b>
<b>4.9</b>	<b>Report Configuration .....</b>	<b>108</b>
<b>4.10</b>	<b>Service configuration .....</b>	<b>111</b>
4.10.1	Hardware I/O Simulation .....	111
4.10.2	Update feature .....	113
<b>4.11</b>	<b>File Delete .....</b>	<b>114</b>
<b>4.12</b>	<b>Logout .....</b>	<b>115</b>
<b>4.13</b>	<b>Change Password .....</b>	<b>116</b>
<b>5 Display .....</b>		<b>117</b>
<b>5.1</b>	<b>Group .....</b>	<b>118</b>
<b>5.2</b>	<b>Combination Views .....</b>	<b>123</b>
Combination View (3 groups): .....		124
Combination View (2 Groups Top/Bottom): .....		124
Combination View (4 groups): .....		125
<b>5.3</b>	<b>Measurement Value Overview .....</b>	<b>125</b>
<b>5.4</b>	<b>Message Overview .....</b>	<b>126</b>
5.4.1	Alarm Log .....	127
5.4.2	User Messages .....	128
5.4.3	Device Messages .....	128
5.4.4	Interface Status Overview .....	129
5.4.4.1	MODBUS Status .....	130

5.4.4.2	FTP Status .....	131
5.4.4.3	Email Status .....	133
5.4.5	Device Information .....	133
<b>5.5</b>	<b>Analog Output Overview .....</b>	<b>134</b>
<b>5.6</b>	<b>Historic Data .....</b>	<b>136</b>
<b>5.7</b>	<b>Batch Display.....</b>	<b>140</b>
<b>5.8</b>	<b>Reporting Display .....</b>	<b>145</b>
<b>6</b>	<b>User Message .....</b>	<b>146</b>
<b>7</b>	<b>Shortcut Bar .....</b>	<b>147</b>
<b>7.1</b>	<b>Alarm Acknowledgement.....</b>	<b>147</b>
<b>7.2</b>	<b>USB.....</b>	<b>148</b>
<b>8</b>	<b>UserKey 1 and UserKey 2 .....</b>	<b>150</b>
<b>8.1</b>	<b>User Key FTP .....</b>	<b>150</b>
<b>8.2</b>	<b>User Key Email .....</b>	<b>153</b>
<b>8.3</b>	<b>User Key Screen Shot .....</b>	<b>154</b>
<b>8.4</b>	<b>User Key Batch Start/Stop .....</b>	<b>155</b>
<b>8.5</b>	<b>User Key Counter Reset.....</b>	<b>156</b>
<b>8.6</b>	<b>User Key Reset Cal .....</b>	<b>157</b>
<b>8.7</b>	<b>User Key Hide / Disp Scale .....</b>	<b>157</b>
<b>8.8</b>	<b>User Key Hide/ Disp Num .....</b>	<b>158</b>
<b>8.9</b>	<b>User Key Change Display .....</b>	<b>159</b>
<b>9</b>	<b>Browser Overview and Functionality .....</b>	<b>163</b>
<b>9.1</b>	<b>Start-up and Main Screen.....</b>	<b>163</b>
9.1.1	Main Screen Overview .....	163
9.1.2	Login Procedure.....	166
<b>9.2</b>	<b>Menu .....</b>	<b>168</b>
9.2.1	<i>Basic Configuration .....</i>	<i>168</i>
9.2.1.1	<i>Authentication .....</i>	<i>169</i>
9.2.1.1.1	<i>Log-In.....</i>	<i>170</i>
9.2.1.1.2	<i>Add User.....</i>	<i>177</i>
9.2.1.1.3	<i>View/Edit User .....</i>	<i>179</i>
9.2.1.1.4	<i>Enable Login .....</i>	<i>180</i>
9.2.1.2	<i>Communication Menu.....</i>	<i>181</i>
9.2.1.2.1	<i>MODBUS Settings.....</i>	<i>181</i>
9.2.1.2.2	<i>Ethernet Settings .....</i>	<i>182</i>
9.2.1.2.3	<i>DNS Setting .....</i>	<i>184</i>
9.2.1.2.4	<i>FTP Settings .....</i>	<i>185</i>
9.2.1.2.5	<i>FTP Scheduling .....</i>	<i>185</i>
9.2.1.2.6	<i>Email Settings.....</i>	<i>187</i>
9.2.1.2.7	<i>Schedule Email.....</i>	<i>188</i>
9.2.1.2.8	<i>Browser Application Permissions .....</i>	<i>189</i>
9.2.1.3	<i>Enable Help .....</i>	<i>190</i>
9.2.1.4	<i>Internal Memory Function .....</i>	<i>191</i>
9.2.1.5	Languages .....	191
9.2.1.6	Temperature .....	192

9.2.1.7	Alarm Relays .....	193
9.2.1.8	Date and Time .....	194
9.2.1.9	Device Data .....	195
9.2.1.10	Memory Alarm Configuration.....	196
9.2.1.11	Operating Pause .....	197
9.2.1.12	Timer .....	198
9.2.1.13	User Keys .....	199
9.2.2	Channel configuration .....	201
9.2.3	Analog Output Channel Configuration.....	217
9.2.4	Group Configuration .....	218
9.2.5	Display configuration .....	220
9.2.6	Display settings.....	221
9.2.7	User Messages Entry .....	223
9.2.8	Batch configuration .....	224
9.2.9	Report Configuration.....	226
9.2.10	Recorder Operation .....	227
9.2.10.1	Operations.....	227
9.2.10.2	Generate Message.....	229
9.2.10.3	Download Files.....	230
9.2.11	Service configuration.....	231
9.2.10.1	Hardware I/O Simulation .....	231
9.2.11	Display.....	233
9.2.11.1	Groups.....	233
9.2.11.2	Combination View.....	240
9.2.11.2.1	Combination View 1.....	241
9.2.11.2.2	Combination View 2.....	241
9.2.11.2.3	Combination View 3.....	242
9.2.11.2.4	Combination View 4.....	243
9.2.11.3	Measurement Value Overview .....	245
9.2.11.4	Message Overview .....	246
9.2.11.4.1	Alarms Log .....	247
9.2.11.4.2	User Messages Entry.....	248
9.2.11.4.3	Device Messages .....	248
9.2.11.4.4	Interface Status Overview .....	249
9.2.11.4.4.1	MODBUS Status.....	249
9.2.11.4.4.2	FTP Status.....	250
9.2.11.4.4.3	Email Status.....	251
9.2.11.4.5	Device Information.....	252
9.2.11.5	Historic Data .....	253
9.2.11.6	Batch Display.....	258
9.2.11.7	Reporting Display .....	261
9.2.12	Change Password .....	264
	By selecting this option the page below will be displayed.....	264
9.2.13	Logout .....	265
9.2.14	Miscellaneous Points .....	266
<b>9.2.14.1</b>	<b>Server Time out .....</b>	<b>266</b>

<b>9.2.14.2 Navigator .....</b>	<b>268</b>
<b>10 File Conversion tool .....</b>	<b>270</b>
<b>10.1 Introduction to File conversion tool .....</b>	<b>270</b>
<b>10.2 Using File conversion tool .....</b>	<b>270</b>
10.2.1 Hide .....	271
10.2.2 Settings .....	271
10.2.3 View log .....	272
10.2.4 Convert now .....	272
<b>11 Offline Configuration Tool.....</b>	<b>273</b>
<b>12 Appendix .....</b>	<b>278</b>
<b>12.1 APPENDIX A: RECORDER MODBUS/RTU SLAVE OPERATION.....</b>	<b>278</b>
12.1.1 Wiring Diagram/Pin Configuration of RS-485 Modbus connection .....	278
12.1.2 Modbus Address map Table .....	278

# 1 Introduction to Paperless Recorder

Paperless Recorder is a state-of-the-art industrial controller with data acquisition, recording and trending system. It has a set of real-time channels with universal inputs available at its back-end and another set of channels available when connected into super-ordinate MODBUS (RTU/TCP) network. It also supports an extensively configurable control mechanism using a set of directly available relays.

The Paperless Recorder comes with a wide range of networking features (such as E-Mail and FTP Transfer support) for sharing data, and supports remote access by a PC-Based Browsing Application, that is equipped to perform all the recorder operations from any location.

## 2 Instrument Description

### 2.1 *Installation and Wiring*

Read the instructions carefully which are mentioned below, before proceeding with installation and operation. It should be kept away from shock, vibration, and electromagnetic fields like motors or transformers. Installation should be performed only by the qualified personnel.

**CAUTION: The Instrument AC power input is specified in the model number and on the wiring label affixed to the back of the unit. Verify the AC power input required by the instrument prior to installation.**

### 2.2 *Unpacking*

If any damage been found while unpacking, the user should contact the local representative. The special packaging is suggested to retain for possible future requirement. Write the model number and serial number of the instrument on inner side of the front cover of this operation manual for future reference.

### 2.3 *Location*

Locate the instrument away from excessive moisture, oil, dust and vibration. Do not subject the instrument to operating temperatures outside of the 32° to 131°F (0° to 55°C) range.

### 2.4 *Mounting*

Figure 2.1 shows an installation view and physical dimensions for a panel mounted instrument. The panel where the instrument will be mounted must provide rigid support for the approximately 20 pound instrument. Adjacent instruments may be mounted within a minimum of 2 inches horizontally and 3 inches vertically, providing that proper panel support is supplied.

PANEL MOUNTING HARDWARE REQUIRED: (provided with instrument)

**PANEL MOUNTING:**

- 1) Cut panel opening to the dimensions illustrated in Figure 2.1.
- 2) Insert the instrument in the panel opening. Firmly fasten the instrument to the panel using the clamps provided.

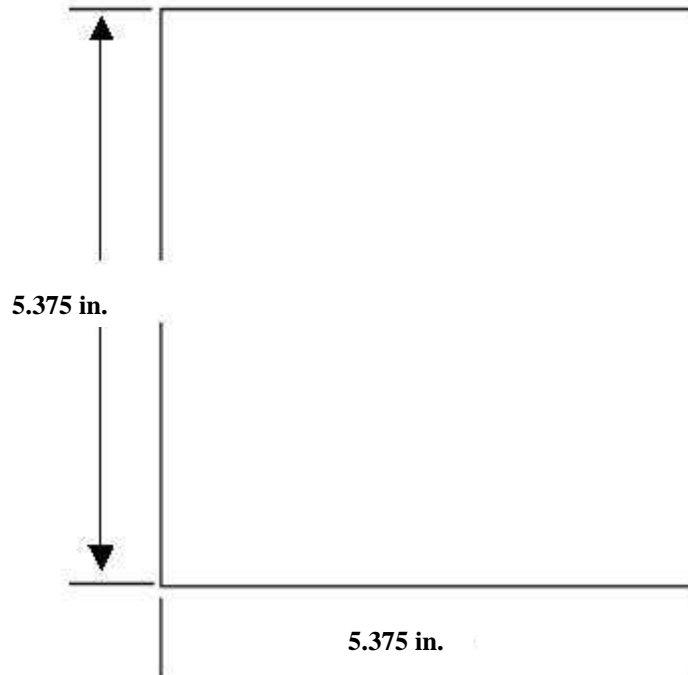

Figure 2.1

## **2.5 Preparation for Wiring**

### **2.5.1 WIRING GUIDELINES**

Electrical noise is a phenomenon observed in industrial environments. The following are guidelines that must be followed to minimize the effect of noise in an instrument.

#### **2.5.1.1 INSTALLATION CONSIDERATIONS**

Listed below are some of the common sources of electrical noise in the industrial environment:

- Ignition Transformers
- Arc Welders
- Mechanical contact relay(s)
- Solenoids

Before using any instrument near the devices listed, the instructions below should be followed:



1. If the instrument is to be mounted in the same panel as any of the listed devices, separate them by the largest distance possible. For maximum electrical noise reduction, the noise generating devices should be mounted in a separate enclosure.
2. If possible, eliminate mechanical contact relays and replace them with solid state relays. If a mechanical relay being powered by an instrument output device cannot be replaced, a solid state relay can be used to isolate the instrument.
3. A separate isolation transformer to feed only instrumentation should be considered. The transformer can isolate the instrument from noise found on the AC power input.
4. If the instrument is being installed on existing equipment, the wiring in the area should be checked to ensure that good wiring practices have been followed.

### **2.5.1.2 AC POWER WIRING**

#### **Earth Ground**

The instrument includes noise suppression components that require an earth ground connection to function. To verify that a good earth ground is being attached, make a resistance check from the instrument chassis to the nearest metal water pipe or proven earth ground. This reading should not exceed 100 ohms. Each instrument should have a dedicated earth ground. Do not chain-link multiple instrument ground wires.

#### **Neutral (For 115VAC)**

It is good practice to assure that the AC neutral is at or near ground potential. To verify this, a voltmeter check between neutral and ground should be done. On the AC range, the reading should not be more than 50 milli-volts. If it is greater than this amount, the secondary of this AC transformer supplying the instrument should be checked by an electrician. A proper neutral will help ensure maximum performance from the instrument.

### **2.5.1.3 WIRE ISOLATION/SEGREGATION**

The instrument is designed to promote proper separation of the wiring groups that connect to the instrument. The AC power wire terminals are located near the bottom of the instrument. Maintain this separation of the wires to ensure the best protection from electrical noise. If the wires need to be run parallel with any other wiring type(s), maintain a minimum of 6 inch space between the wires. If wires must cross each other, do so at 90 degrees to minimize the contact with each other and reduce cross talk. Cross talk is due to the Electro Magnetic Field emitted by a wire as a current passes through it.

### **2.5.1.4 USE OF SHIELDED CABLE**

Shielded cable helps eliminate electrical noise being induced on the wires. All analog signals should be run with shielded cable. Connection lead length should be kept as short as possible, keeping the wires protected by the shielding. The shield should be grounded at one end only. The preferred grounding location is at the sensor, transmitter or transducer.

### 2.5.1.5 NOISE SUPPRESSION AT THE SOURCE

Usually, when good wiring practices are followed, no further noise protection is necessary. Sometimes in severe electrical environments, the amount of noise is so great that it has to be suppressed at the source. Many manufacturers of relays/contactors/etc. supply “surge suppressors” which mount on the noise source.

For those devices that do not have surge suppressors supplied, RC (resistance-capacitance) networks and/or MOV (metal oxide varistors) may be added.

Inductive Coils – MOV’s are recommended for transient suppression in inductive coils connected in parallel and as close as possible to the coil. See Figure 2-2. Additional protection may be provided by adding an RC network across the MOV.

Contacts – Arcing may occur across contacts when the contact opens and closes. This results in electrical noise as well as damage to the contacts. Connecting a RC network properly sized can eliminate this arc.

For circuits up to 3 amps, a combination of a 47 ohm resistor and 0.1 microfarad capacitor (1000 volts) is recommended. For circuits from 3 to 5 amps, connect 2 of these in parallel. See Figure 2.3.

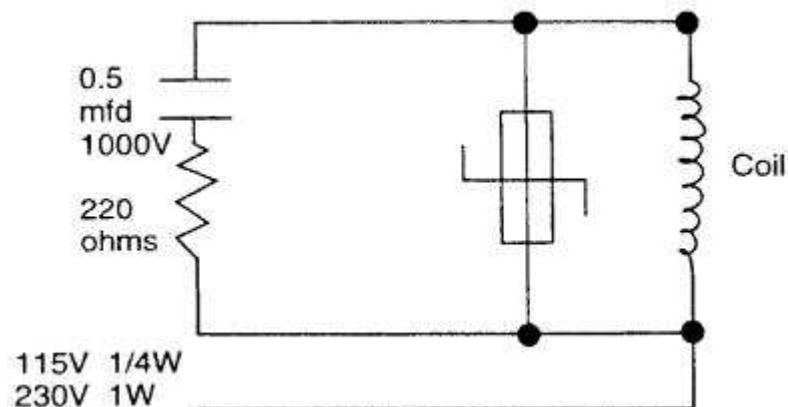

Figure 2.2

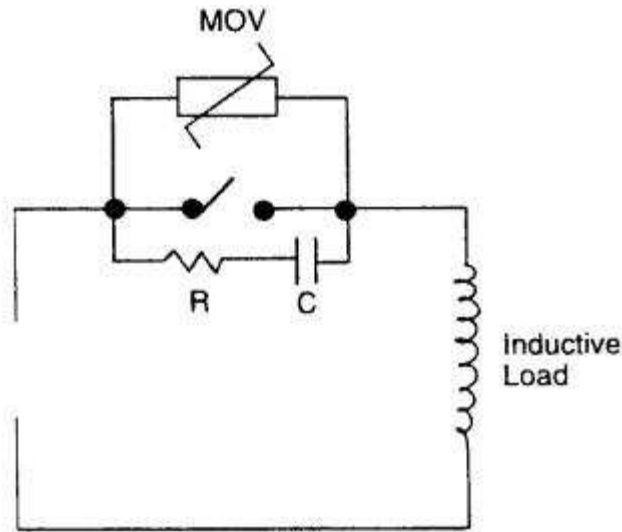

Figure 2.3

### 2.5.2 SENSOR PLACEMENT (THERMOCOUPLE OR RTD)

Thermocouple lead resistance should not exceed 300 ohms. If this is exceeded, instrument accuracy could be affected.

Two wire RTD's should be used only with lead lengths less than 10 feet.

If the temperature probe is to be subjected to corrosive or abrasive conditions, it should be protected by the appropriate thermo well. The probe should be positioned to reflect true process temperature:

In liquid media – the most agitated area.

In air – the best circulated area.

#### ***THERMOCOUPLE LEAD RESISTANCE***

Thermocouple lead length can affect instrument accuracy since the size (gauge) and the length of the wire affect lead resistance.

To determine the temperature error resulting from the lead length resistance, use the following equation:

$$T_{err} = TLe * L \quad \text{where; } TLe = \text{value from appropriate table below}$$

$$L = \text{length of lead wire in thousands of feet}$$

Temperature error in °C per 1000 feet of Leadwire									
AWG No.	Thermocouple Type:								
	J	K	T	R	S	E	B	N	C
10	.68	1.71	.76	2.05	2.12	1.15	14.00	2.94	2.53
12	1.08	2.68	1.21	3.30	3.29	1.82	22.00	4.68	4.07
14	1.74	4.29	1.95	5.34	5.29	2.92	35.00	7.44	6.37
16	2.74	6.76	3.08	8.30	8.35	4.60	55.50	11.82	10.11
18	4.44	11.00	5.00	13.52	13.65	7.47	88.50	18.80	16.26
20	7.14	17.24	7.84	21.59	21.76	11.78	141.00	29.88	25.82
24	17.56	43.82	19.82	54.32	54.59	29.67	356.50	75.59	65.27

TABLE 2.1

Temperature error in °C per 1000 feet of Leadwire									
AWG No.	Thermocouple Type:								
	J	K	T	R	S	E	B	N	C
10	.68	1.71	.76	2.05	2.12	1.15	14.00	2.94	2.53
12	1.08	2.68	1.21	3.30	3.29	1.82	22.00	4.68	4.07
14	1.74	4.29	1.95	5.34	5.29	2.92	35.00	7.44	6.37
16	2.74	6.76	3.08	8.30	8.35	4.60	55.50	11.82	10.11
18	4.44	11.00	5.00	13.52	13.65	7.47	88.50	18.80	16.26
20	7.14	17.24	7.84	21.59	21.76	11.78	141.00	29.88	25.82
24	17.56	43.82	19.82	54.32	54.59	29.67	356.50	75.59	65.27

TABLE 2.2

Example:

A paperless recorder is to be located in a control room 660 feet away from the process. Using 16 AWG, type J thermocouple, how much error is induced?

$$T_{err} = TLe * L$$

$$TLe = 4.93 \text{ (}^\circ\text{F/1000 ft) from Table 2.2}$$

$$T_{err} = 4.93 \text{ (}^\circ\text{F/1000 ft) * 660 feet}$$

$$T_{err} = 3.3 \text{ }^\circ\text{F}$$

### RTD LEAD RESISTANCE

RTD lead length can affect instrument accuracy, since the size (gauge) and length of the wire affect lead resistance.

To determine the temperature error resulting from the lead length resistance, use the following equation:

$$T_{err} = TLe * L$$

RTD

where; TLe = value from Table 2.3 if 3 wire RTD or Table 2.4 if 2 wire

L = length of lead wire in thousands of feet

AWG No.	Error °C	Error °F
10	+/- 0.04	+/-0.07
12	+/- 0.07	+/-0.11
14	+/- 0.10	+/-0.18
16	+/- 0.16	+/-0.29
18	+/- 0.26	+/-0.46
20	+/- 0.41	+/-0.73
24	+/- 0.65	+/-1.17

TABLE 2.3 3-Wires RTD

AWG No.	Error °C	Error °F
10	+/- 5.32	+/-9.31
12	+/- 9.31	+/-14.6
14	+/- 13.3	+/-23.9
16	+/- 21.3	+/-38.6
18	+/- 34.6	+/-61.2
20	+/- 54.5	+/-97.1
24	+/- 86.5	+/-155.6

TABLE 2.4 2-Wires RTD

Example:

An application uses 2000 feet of 18 AWG copper lead wire for a 3 wire RTD sensor. What is the worst case error due to this lead wire length?

$$T_{err} = TLe * L$$

$$TLe = +/- .46 (°F/1000 ft) \text{ from Table 2.3}$$

$$T_{err} = +/- .46 (°F/1000 ft) * 2000 ft$$

$$T_{err} = +/- 0.92°F$$

## 2.6 Wiring Connections

All wiring connections are typically made to the instrument at the time of installation. Connections should be made at the terminal blocks, using 16 gauge wires maximum, refer Figure 2-4.

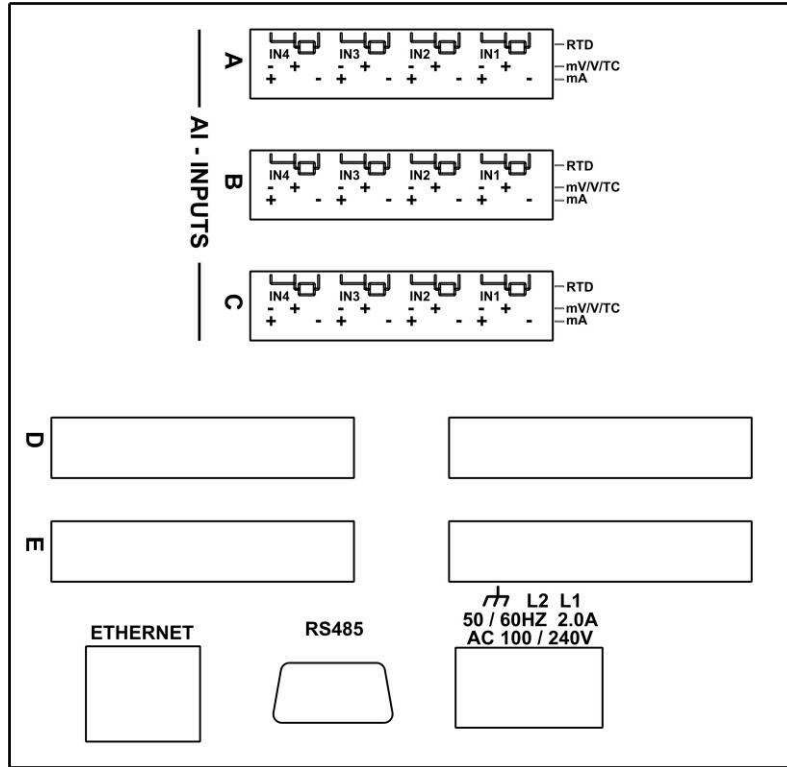

Figure 2.4

### 2.6.1 AC POWER WIRING CONNECTIONS

**WARNING:** Avoid electrical shock. AC power wiring must not be connected at the source distribution panel until all wiring connections are completed.

#### Power Input Connections

AC powered instruments operate from a 100 to 240 V (+/- 10%) 50/60Hz supply. Power consumption is 75W. Connect the line voltage (hot and neutral) as illustrated via a two-pole isolating switch (preferably located near the equipment) and a 2.5 amp anti-surge fuse. If the instrument has relay outputs with contacts carrying mains voltage, it is recommended that the relay contacts supply should be switched and fused in a similar manner, but should be separated from the instruments AC supply.

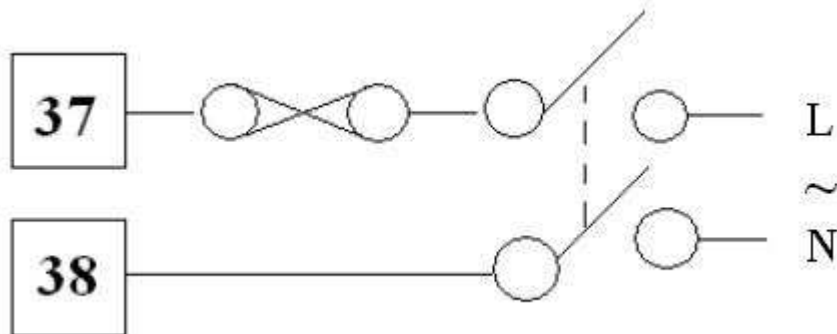

Figure 2.5

## 2.6.2 Thermocouple Inputs

The correct type of extension lead wire/compensation cable must be used for the entire distance between the Loop Module connector and the thermocouple; correct polarity must be observed throughout and joints in the cable should be avoided. If the thermocouple is grounded, this must be done at one point only.

**Note:** Do not run thermocouple cables adjacent to power-carrying conductors. If the wiring is run in a conduit, use a separate conduit for the thermocouple wiring. If the thermocouple is grounded, this must be done at one point only. If the extension lead is shielded, the shield must be grounded at one point only.

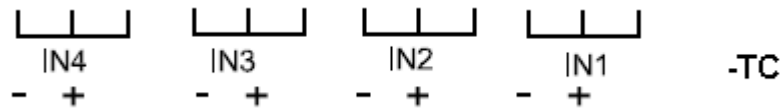

Figure 2.6

## 2.6.3 RTD Input (3-wire)

The extension leads should be copper and the resistance of the wires connecting to the resistance element should not exceed  $50\Omega$  per lead (the leads should be of equal resistance). For three wire RTDs, connect the resistive leg and the common legs of the RTD as illustrated. For a two wire RTD, a wire link should be used in place of the third wire (shown by dotted line). Two wire RTDs should only be used when the leads are less than 3 meters long. Avoid cable joints.

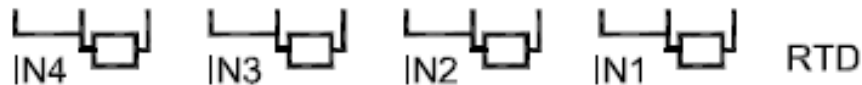

Figure 2.7

## 2.6.4 Linear Inputs

Linear DC voltage, milli-volts or milliamp input connections are made as illustrated. Carefully observe the polarity of the connections.

### Volts and milli-volts inputs

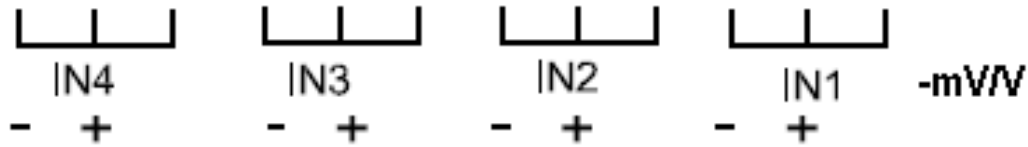

Figure 2.8

**Milliamp inputs**

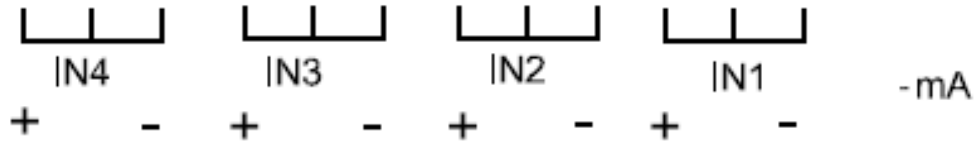

Figure 2.9

**2.6.5 OUTPUT CONNECTIONS**

**Relay Outputs**

The relay outputs are Single pole Single throw and are rated at 2A resistive 120/240VAC.

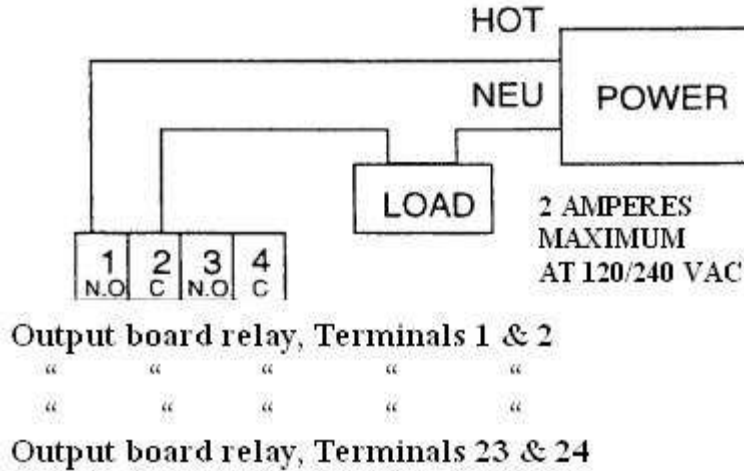

Figure 2.10

**SPST Relay Output**

Connections are made to relays 1 through 12 as shown. Terminal connections are made to output board Driver 1 through 12.





**Current Output**

Connections are made to current outputs A through D as shown. Each current output is programmable as either 4 to 20 mADC or 0 to 20 mADC. Each output must be assigned to the desired function. Terminal connections are made using Input 1 through Input 3. Current outputs will operate up to 650 ohms maximum load.

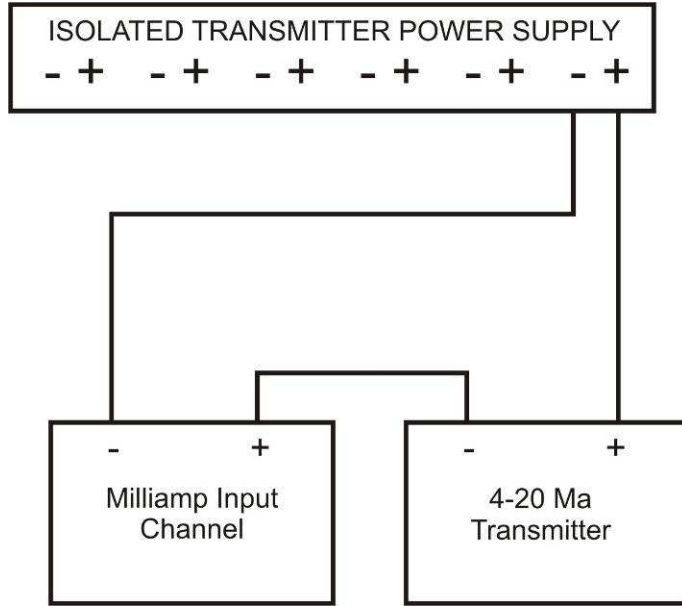

Figure 2.14

**2.6.6 TRANSMITTER POWER SUPPLY**

Isolated transmitter power supplies may be supplied in either a six or twelve count board configuration. Each set of terminals should only be used to provide loop voltage to a single 4-20 mA transmitter.

Wiring is as follows:



Relay pin details

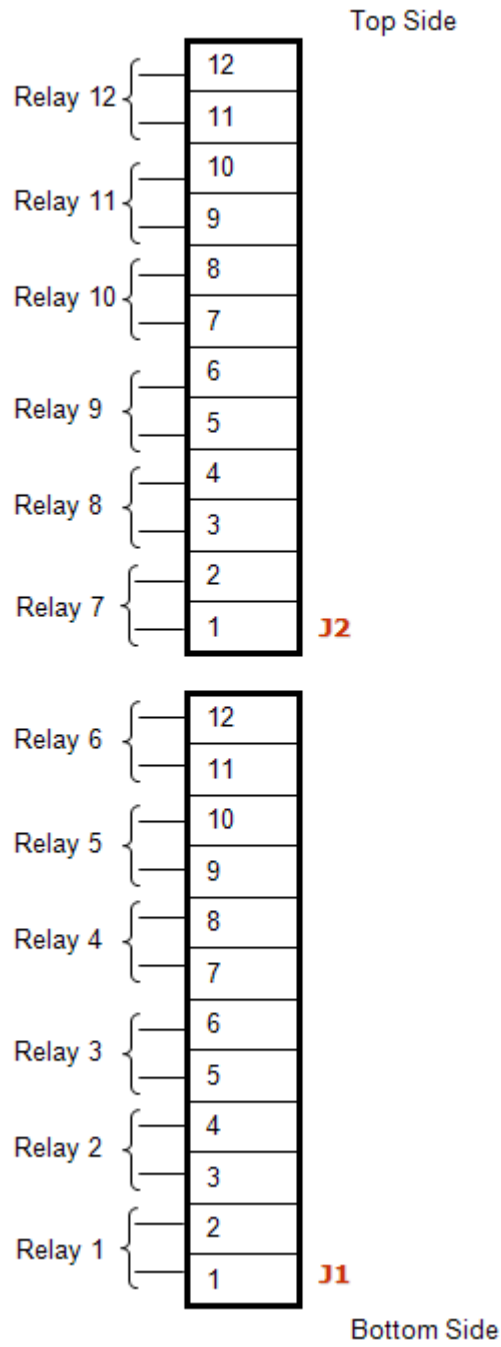
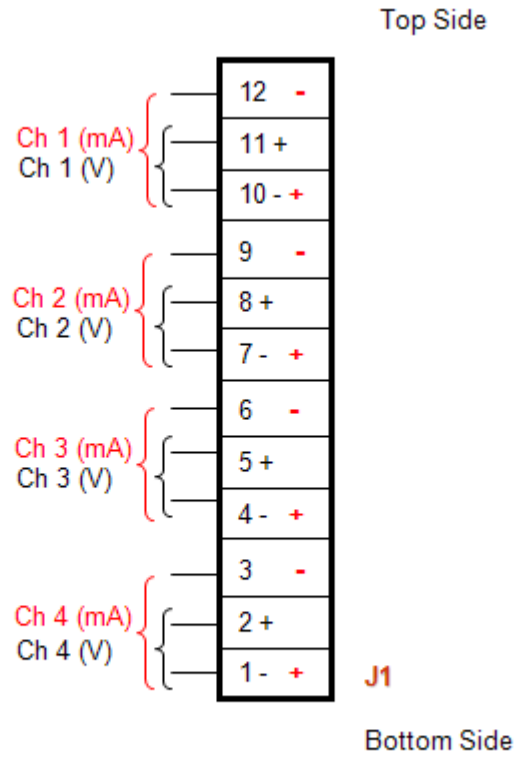

Figure 2.14(a)

Analog Input pin details



Texts in Red - Current

Figure 2.14(b)

### 2.6.7 Digital Input Card Connections

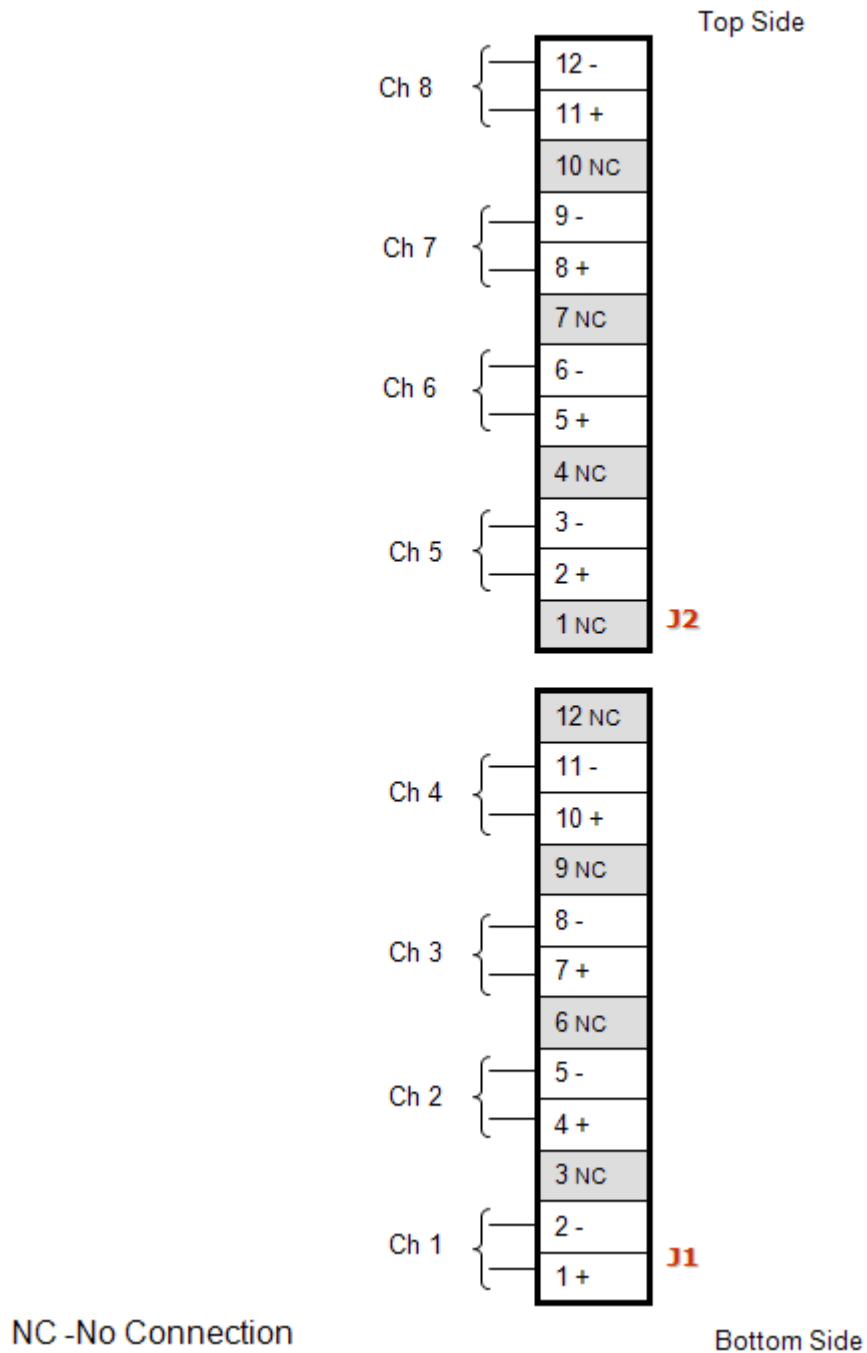

Figure 2.15

**Voltage input:**

According to above DI card pin configuration,

- If input voltage is -3V to 5V then Recorder will consider as Logic Low.
- If input voltage is 5V to 10V then Recorder will consider as Logic Low or Logic High.
- If input voltage is greater than  $> 10V$  then Recorder will consider as Logic High.

### 2.6.8 Analog Output Card Connections

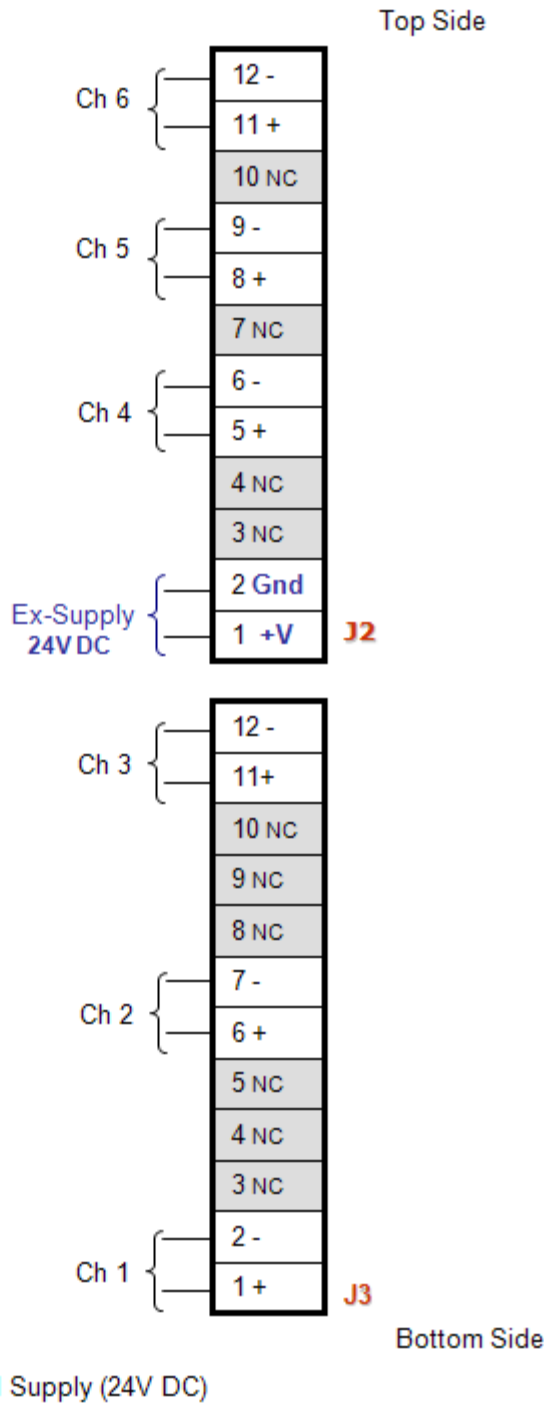

Figure 2.16

**Note:** Using AO card with external Power supply, connect all the jumpers between pin 2 and 3 instead of pin 1 and 2.

The analog output card will have 6 (Six) channels. Each channel output can be either 0-20mA or 4-20mA. The channels are individually isolated. Isolation required is 500Veff. The card has to be powered by the recorder supply.

## **2.7 Input Channels**

### **2.7.1 Onboard Channels**

All the channels (Analog and Digital input) that are directly available with the Paperless Recorder are called the On-Board Channels.

#### **2.7.1.1 Onboard Analog Input Channels**

The Recorder can support up to 12 universal Analog input On-Board channels (Recorder supports 3 AI cards). The actual number of input channels available however depends upon the number and type of input cards present with it. An input card can be 'single input', 'dual input' or 'quad input' type. The Recorder comes with any combination of Input cards up to a maximum of three input cards at a time. To use each of these On-Board Analog inputs for different types of Analog input signals (i.e., voltage ranges, current ranges, TC or RTD ranges), they must first be configured for the corresponding type. If not, the values displayed/recorded may be un-predictable. For configuration details, see channel configurations (section 4.2). 'On-Board channel 1' shall always be 'Input 1' of 'input card 1' and all subsequent available inputs shall be given progressive on-board channel numbers.

#### **2.7.1.2 Onboard Digital Input Channels**

The Recorder can support maximum 8 On-Board Digital Input channels. The Recorder comes with maximum of 1 Digital Input card. To use each of these On-Board Digital Inputs (i.e. counter input, 1:1, Operating pause), they must first be configured for the corresponding type. If not, the values displayed/recorded may be up-predictable. For configuration details, see channel configurations (section 4.2).

NOTE: The Instrument shall not launch in a normal fashion and shall get halted with an error message in any of the following cases:

1. If the number of output Relay cards found is more than 1.
2. If the number of Analog output cards found is more than 1.
3. If the number of Analog input cards found is more than 3.
4. If the number of Digital input cards found is more than 1.
5. If there is a failure in Opening COM port for scanning of On-Board Channels (Failure to Open LCM Port)



6. If there is a failure in Opening COM port for scanning of External RTU Channels (Failure to Open External Port)

### 2.7.2 External Channels

External Channels enable the Recorder to get data values from other slave devices, when Recorder is configured as Master in a MODBUS (RTU or TCP) network. The Recorder supports a maximum of 12 external channels. Of the total available external channels, each channel can be individually configured as an 'External MODBUS RTU' channel or an 'External MODBUS TCP' channel, depending on whether the interface chosen between the Recorder and the Slave device is RS-485. The Interface Type (TCP or RTU), IP Address of Slave device (if TCP is selected as the interface), the MODBUS Slave Address, the parameter register address and the number of words to read (starting from the given parameter address) are configurable for each channel individually. The serial port settings for External MODBUS RTU channels can be done in the MODBUS Settings Dialog Box. It is assumed that a 1-word standard process value is present at the register address provided in the respective external channel's configuration, and a status word is present at the immediate next address (if the number of words to be read is specified as two). Status word may be used to pass sensor break information for the associated external channel from slave device to Recorder. Sensor break bit must be present in BIT position 2 of the status word as shown in the figure below. BIT value of 1 indicates sensor break.

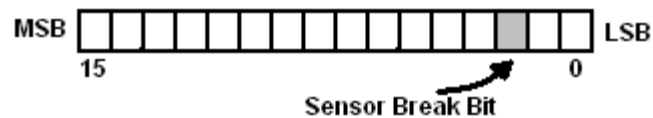

Figure 2.15 (Sensor Break Bit)

### 2.7.3 Calculation Channels

The Recorder supports a maximum of 12 calculation channels. These are calculated channels (non-physical) derived from the external and/or On-Board Channels. The user can define the mathematical formula that must be used to compute the value of a calculation channel. This may be set individually for each calculation channel. Other channels might be used as a part of the formula. E.g.: calculation channel 1 may be defined with the formula: Ch1 + Ch26. For details of configuring calculation channels, see channel configurations.

Usage of mathematical expression must ensure that the expressions do not become invalid at any point during the run. As an example, if the expression is (Sqrt (AI 1)) i.e. this calculation channel reports square-root of present value of Onboard channel 1 and at some point, Onboard channel 1 has a negative value (say -10.00), then the expression shall become invalid. In such a case Recorder shall indicate an indefinite value represented as Zero. Similarly for On-Board Digital Channel 1 has a value (say -10), then expression log (-10) shall become invalid. In such a case Recorder shall indicate an indefinite value represented as zero. But if at any point any of the

channel receives invalid indefinite input either from externally given input or expression including such channels Recorder shall indicate an indefinite value represented as 'NAN'.

### 3 Start-up and Main Screen

Recorder starts with the boot-up screen shown in figure 3.1 and it will be displayed for 5seconds. Start-up image can be changed using Basic Configuration → Start-up Image menu (Ref. section 4.1.14).

Note: if recorder is powered off when recording is ON or software is upgraded then it will take more than 5 seconds.

#### 3.1 Main Screen and Toolbar Overview

Once the system is ready, the following screen appears

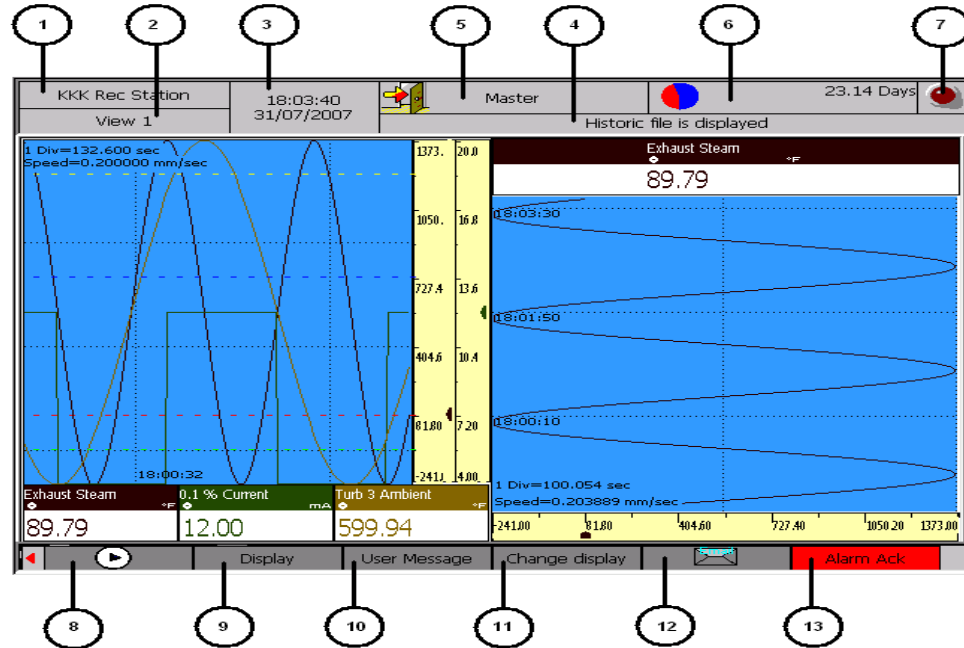







Figure 3.2: Main Screen

In the above figure 3.2

- 1 Displays the *recorder name* that is configured in the basic configuration. Recorder name can be changed by using device configuration dialog.
- 2 Displays currently displayed *group name* or *view name* and so on, depends on the user selection.
- 3 Displays current *date and time* with selected date format in date and time settings dialog.
- 4 User Message (Last message, Ref Section 4.6) entered by the user will be displayed here, if the text is longer than the display length it will scroll across.

- 5 *Login Status*: Toggles from  to  depending on the login status.
- 6 Displays the *remaining memory* in days or hours, depending on the option the user has configured in the Memory alarm configuration dialog. The memory icon will be updated depending on the memory usage. In the Memory icon  Blue color indicates Remaining memory and Red color indicates used memory.
- 7 *Channel Alarms Indicator*: When no alarm present no symbol is displayed. When an alarm is triggered a flashing red indicator (bulb) will be displayed as follows. 
- 8 *Start /Stop*: Toggles the recording status from Start to Stop and vice versa.  
 -Start  - Stop
- 9 *Display*: Used to change the display view of the recorder. For more details [refer to section 5](#).
- 10 *User message*: Opens a window where a pre-defined message or user-defined message can be selected. For more details [refer to section 6](#).
- 11 and 12 display *user keys*, that can be assigned in the user key option. The table below shows the icons for the available user key options in the recorder. [Refer to section 8](#).



Icon	Description
 FTP	FTP
	E-mail
	Hide/Display Scale
	Screen shot

Table 3.1: Icon Description

13 '*Alarm acknowledgement*': This option is added to the shortcut bar only when an alarm is triggered. The Alarm Indicator in the status bar goes away, when the alarm is acknowledged using this key. For more details [refer to section 7](#).

14 *Menu* (Not shown in Fig. 3.2): In this option the user can view the menu. For more details refer to section 4.

The following dialog as shown in fig. 3.3 will be displayed when there is a mismatch between the configuration of recorder and available hardware.

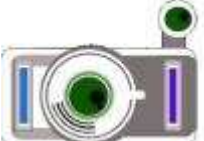
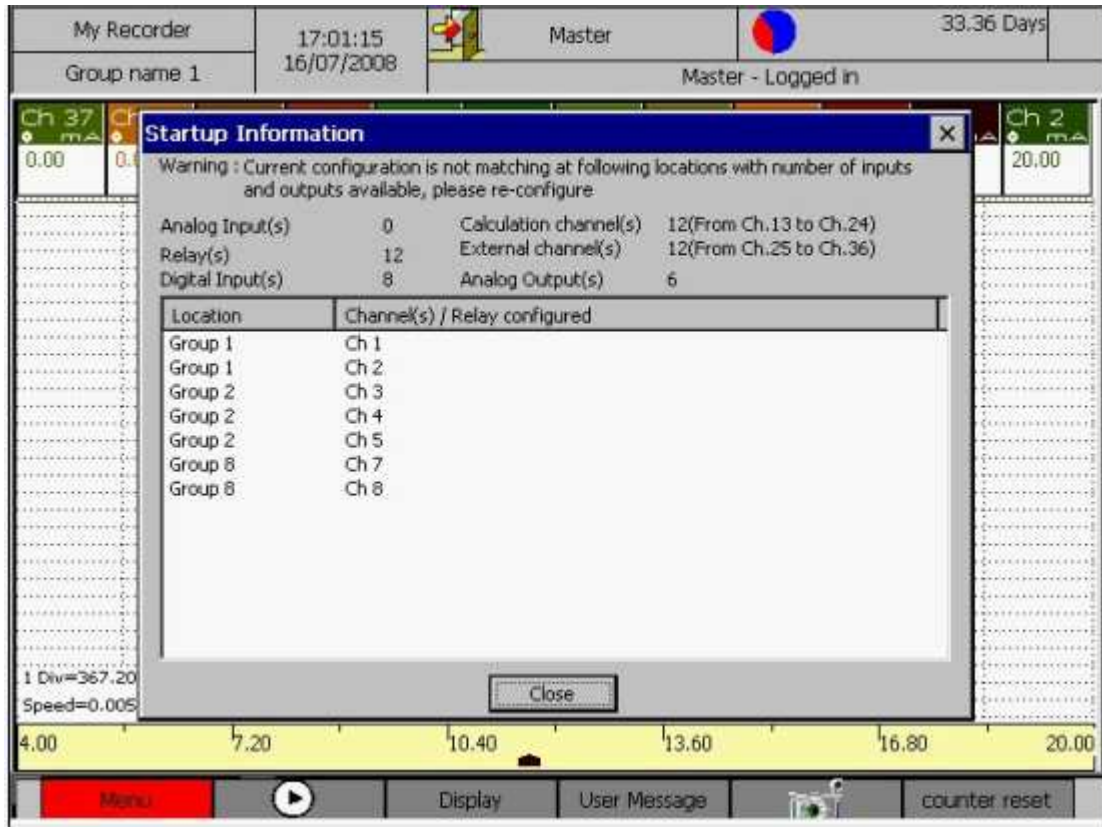

Figure 3.3: Startup Intimation Dialog

### 3.2 Login Procedure

The main menu can be accessed only when the login is deactivated in authentication option of the basic configuration menu (Ref. Section 4.1.1.3). Or if login is activated the user will be prompted to login as shown in the figure 3.4 below.

Note: By default Enable Login factory settings will set to disable state for the first boot of the device. From the subsequent login device will boot according to configuration.

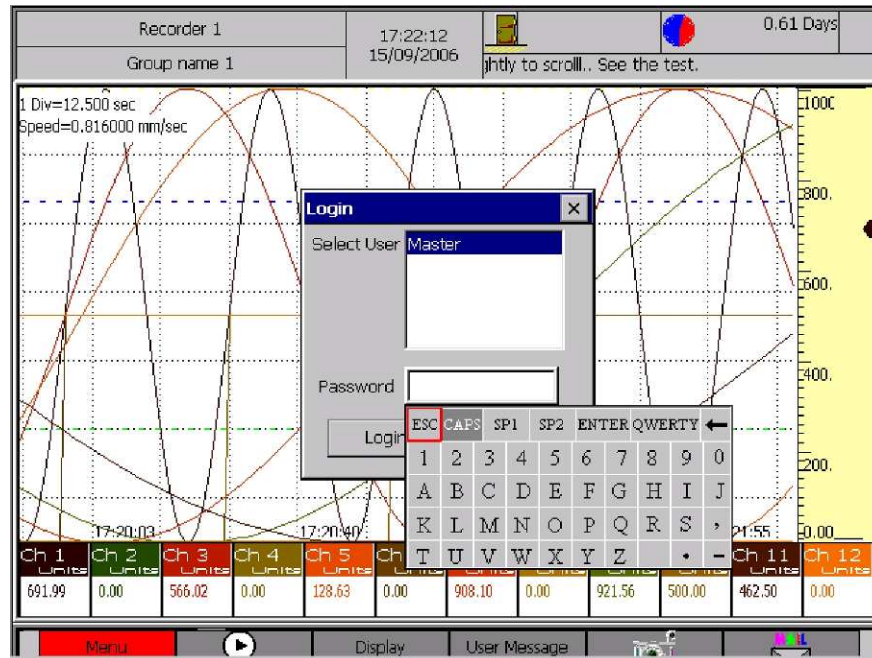

Figure 3.4: User List

This screen will display the list of users, which are configured via the configuration menu (Ref. Section 4.1.1). Here the user can turn the operating unit to scroll through the user list and press to select the username. After selecting the user name, the cursor will move to the Password. Pressing the knob again will open a keyboard where the password can be entered. Use scroll through the characters and press to confirm the character. After entering the password select ENTER to accept the password and ESC to cancel Entered password.

If the password is going to expire in 2days the following dialog will appear.

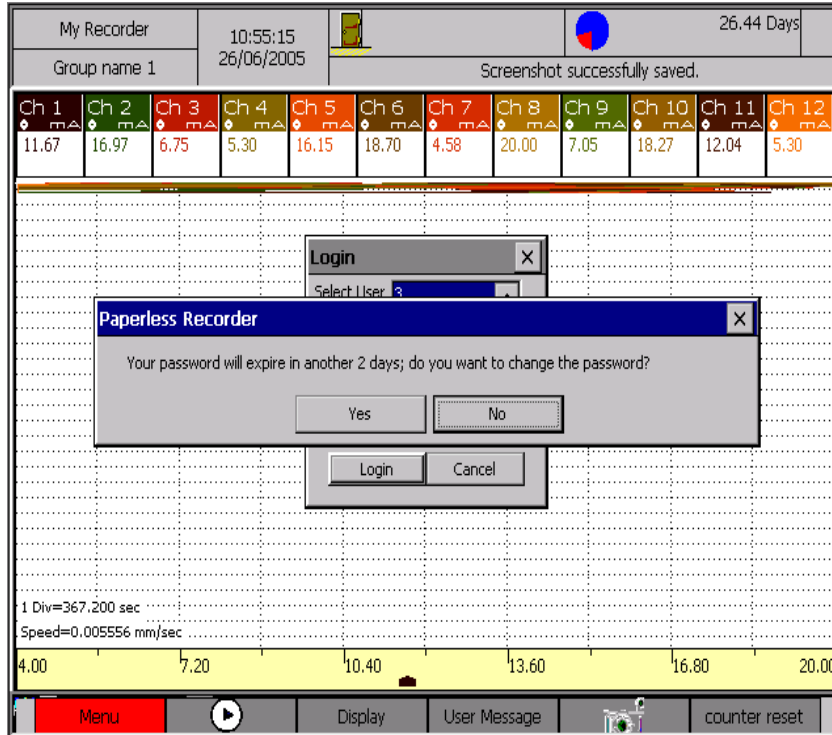

Fig:3.4.1 Login Dialog

If the password is going to expire in 1 day the following dialog will appear.

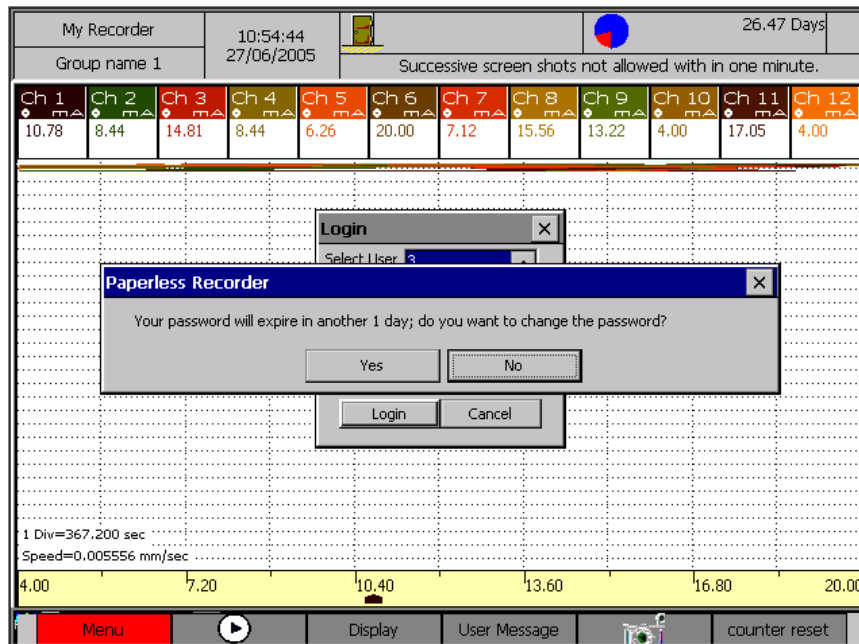
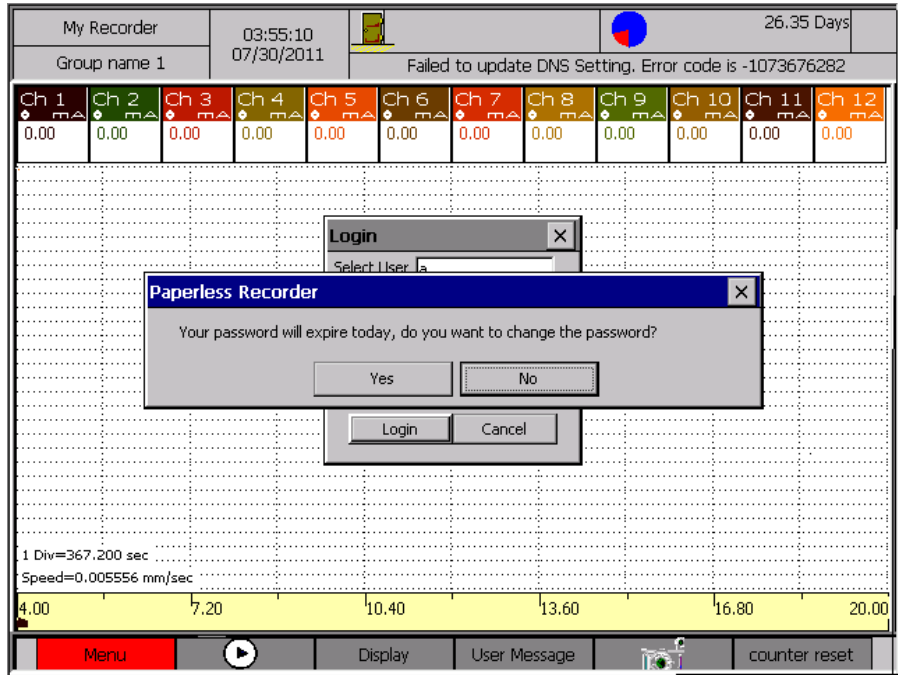

Fig:3.4.2 Login Dialog

On the password expired date.



If the password got expired then the following dialog will appear.

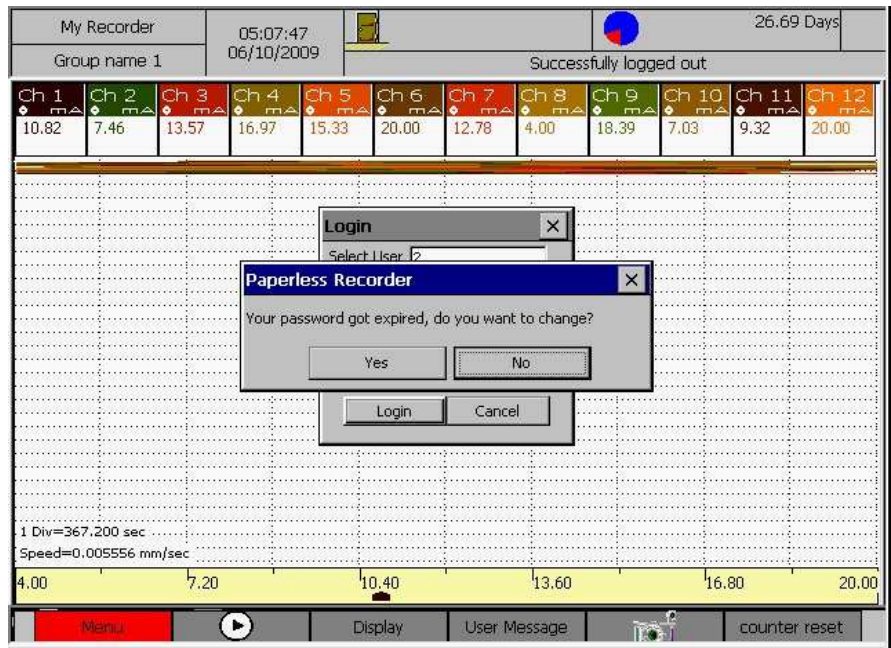

Fig:3.4.3 Login Dialog

Rotate the knob and press “Yes” which displays “Change Password” dialog as shown below. Press “No” if the user doesn’t want to change the pass word. If the expiry period 1day or 2 days user can login without change in password also. If expiry period is over user can not login until changing

the password. And this pass word initializing time and Date will be taken as starting time and date for the next expiry period calculation (time and date at which password got changed/expiry period of user is changed from No expiry to any period). If the operating pause time over then this dialog will disappear without logging in.

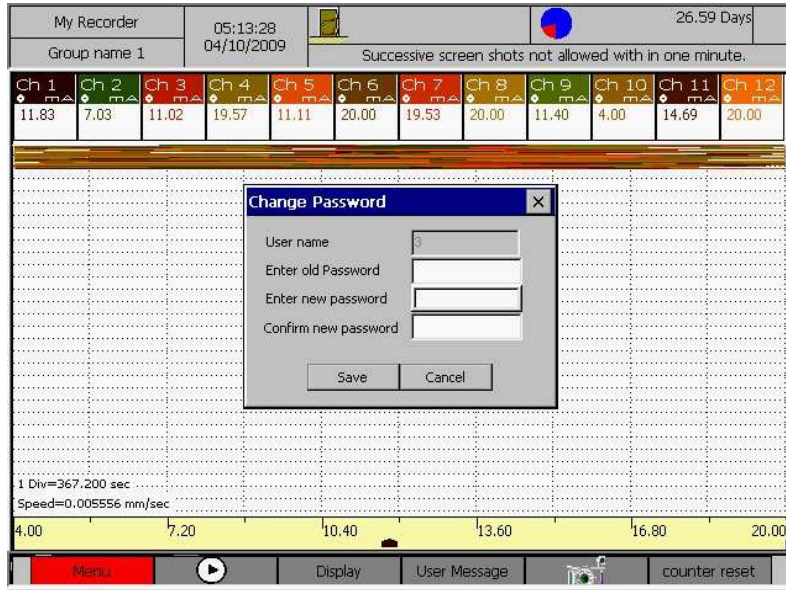

Fig:3.4.4 Change Pass word Dialog

After a successful login, the following screen (Figure 3.5) will come up with the logged in user name in the status box and login icon showing the open door.

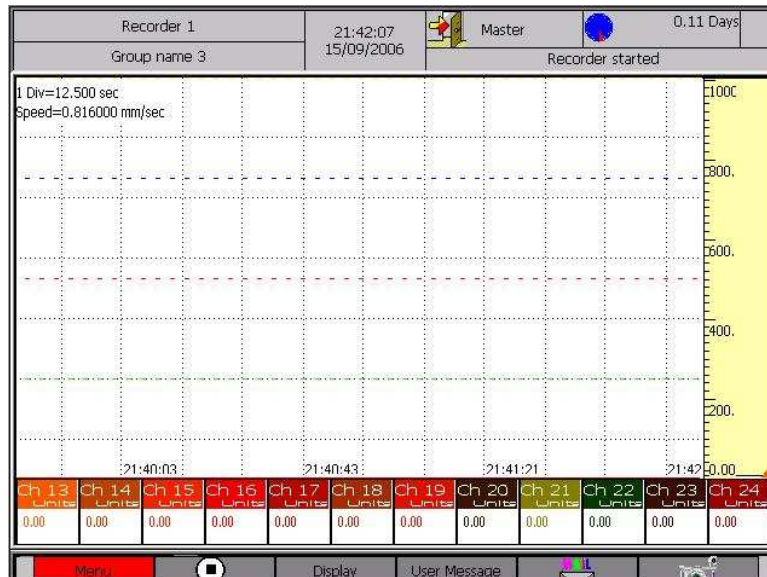

Figure 3.5: Screen after successful login



## 4 Menu

**Note:** Using ESC (Long press) of encoder key, user can back up a level the Menu with out using any of the menu option.

### 4.1 Basic Configuration

The basic configuration menu is shown below

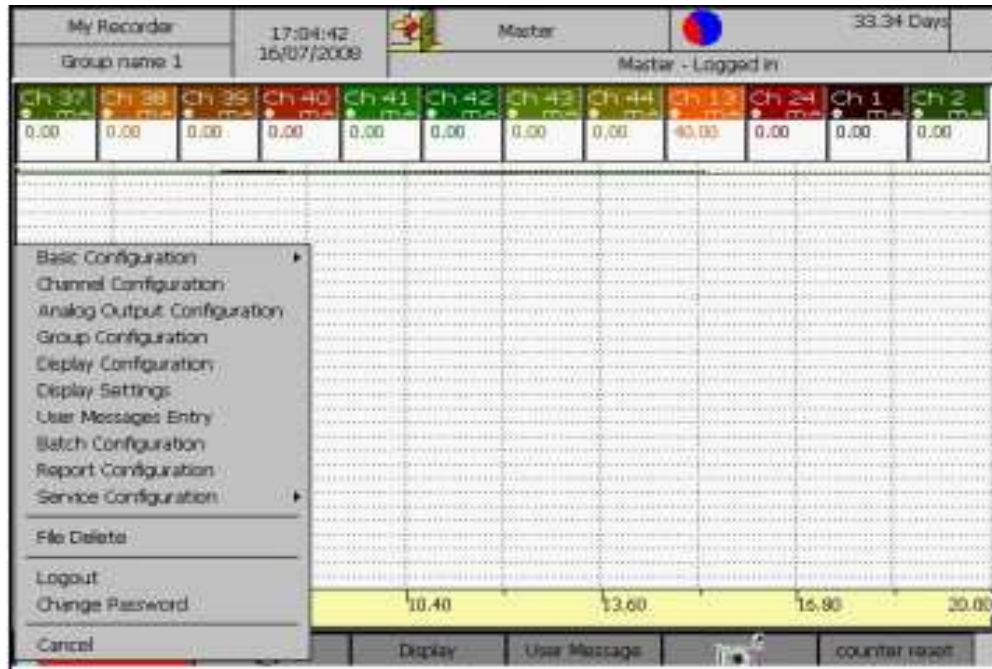

Figure 4.1: Basic Configuration Menu

Procedure: Select the Menu→ Basic Configuration option

#### 4.1.1 Authentication

The Authentication option of the Basic Configuration provides the options for adding, deleting and viewing a user. It also provides the option for enabling/disabling the login control. If the *Enable Login* is enabled, this 'Authentication' option will be available only for the master and a user with Level 6 permissions.

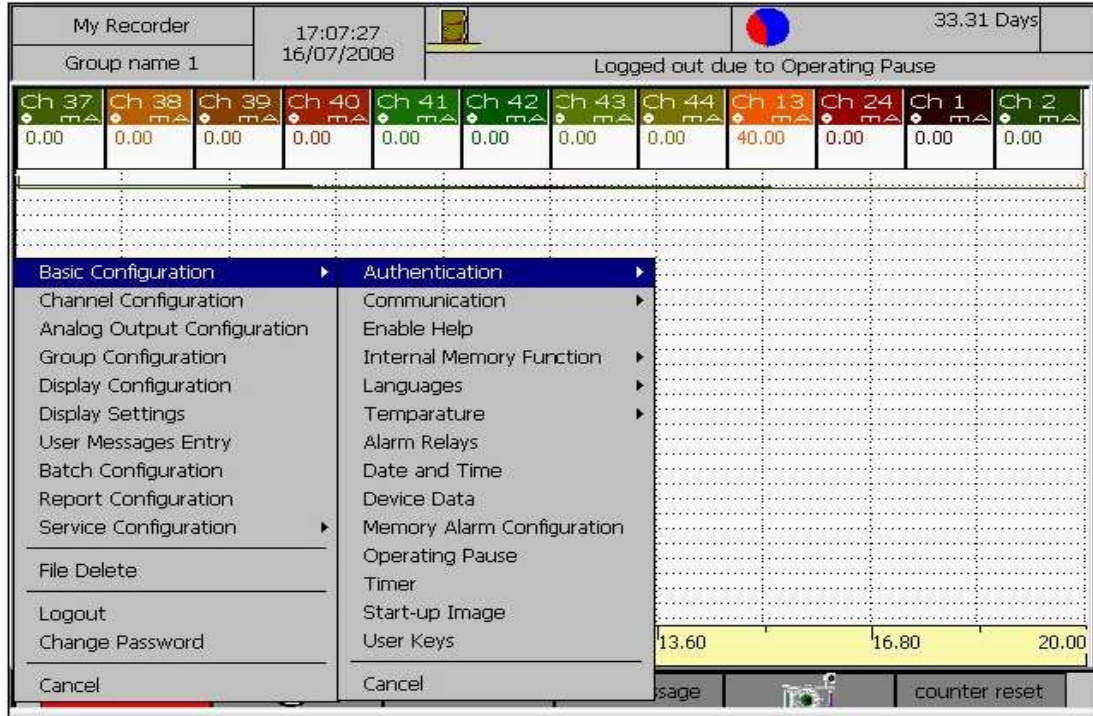

Figure 4.2 : Authentication

#### 4.1.1.1 Add User

A user can be added in the recorder by entering the user name and password and selecting a Permission Level as shown in figure 4.3 the permissions allowed for each level are shown in this screen. Only a master user or a user with permission level 6 can add, delete or view users.

**Username:** A login name to access the recorder (1 to 16 characters, A to Z, a to z and \_ are allowed for the username field).

**Password:** Password for the login name to access the recorder (1 to 8 characters, ‘;’, ‘&’ and ‘+’ not allowed).

**PassWord Expiry:** User can be given different Pass word expiry periods for the user. Password setting time will be taken as starting time for expiry period calculation. It can be 3 months/6 months/9 months /12 months as expiry periods and “No Expiry” if the user don’t want any expiry period.

**Permission level:** Users can be assigned to different permission levels of recorder access.

Permission levels shall be as follows:

- Level 1: Viewing Displays and toggling numeric display and scale, if User keys are assigned for ‘Hide/Display Numeric’ or ‘Hide/Display Scale’.
- Level 2: Viewing all menus and Operation
- Level 3: Viewing all menus, operation and Data Read Out
- Level 4: Viewing all menus, operation, Data read out and Configuring

- Level 5: Viewing all menus, Operation, Data Read Out, Configuring and Deleting Files
- Level 6: Viewing all menus, Operation, Data Read Out, Configuring, Delete Files, Firmware Download and Add or delete user.

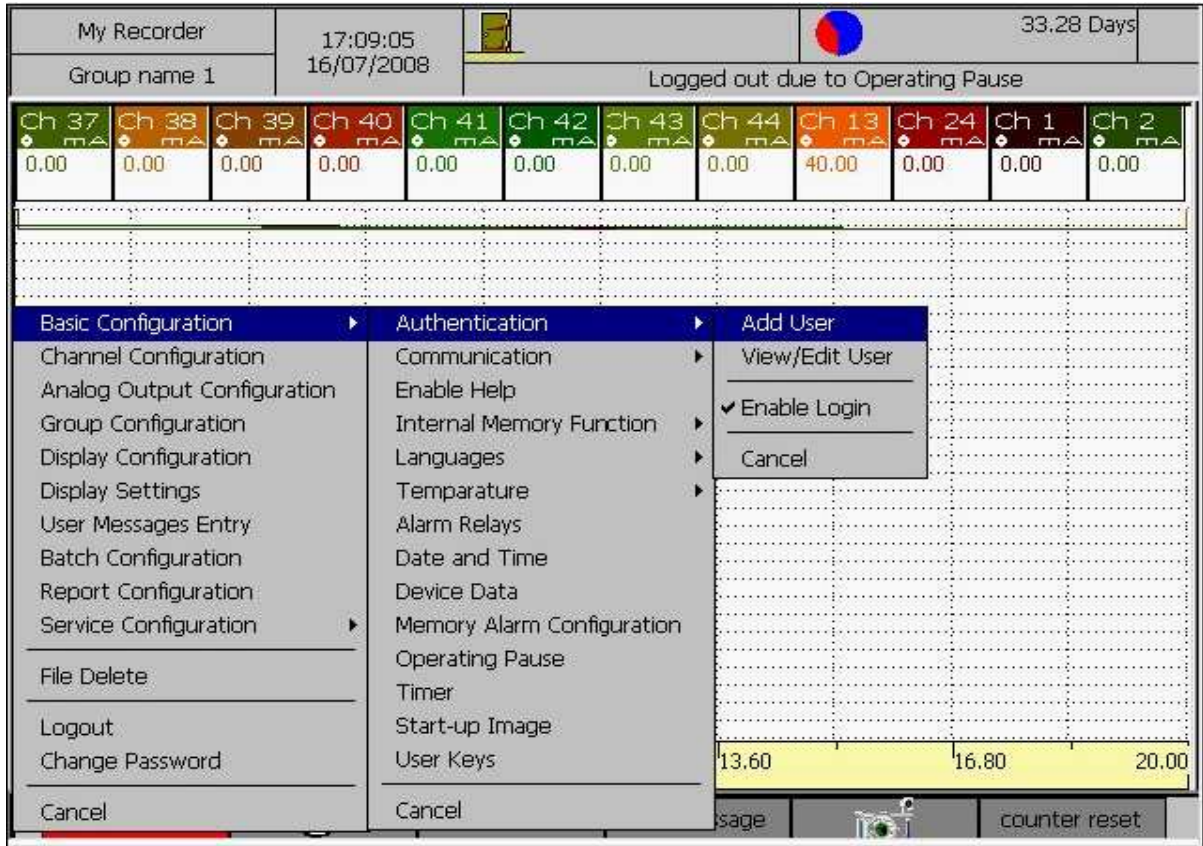

Figure 4. 3: Add User

Description for each option for each permission level is as follows.

- Viewing Displays: User shall be allowed to view all the displays, which shall be available in the 'Display' menu bar.
- Viewing all menus: User shall be allowed to view all the displays and configuration menus.
- Operation: the following operations shall be available to user.
  - Recorder start/stop
  - Generating User Message
  - Alarm acknowledgement
  - Screen dump
  - Batch start/stop
  - Hide/Display numeric value
  - Hide/Display scale
  - Reset Calculation
- Data Read Out: User shall be allowed to download/Upload the following types of files over FTP, E-Mail and USB.
  - Historic data files

- Batch files
- Report files
- Screen shot files
- Configuration: User shall be allowed to configure the recorder.
- Delete files: User shall be allowed to delete the files from recorder memory.
- Firmware Download: User shall be allowed to download the firmware.

Procedure:

1. Select the Menu→ Basic Configuration→ Authentication→ Add User option.
2. Now press the knob to get the below shown figure 4.4.

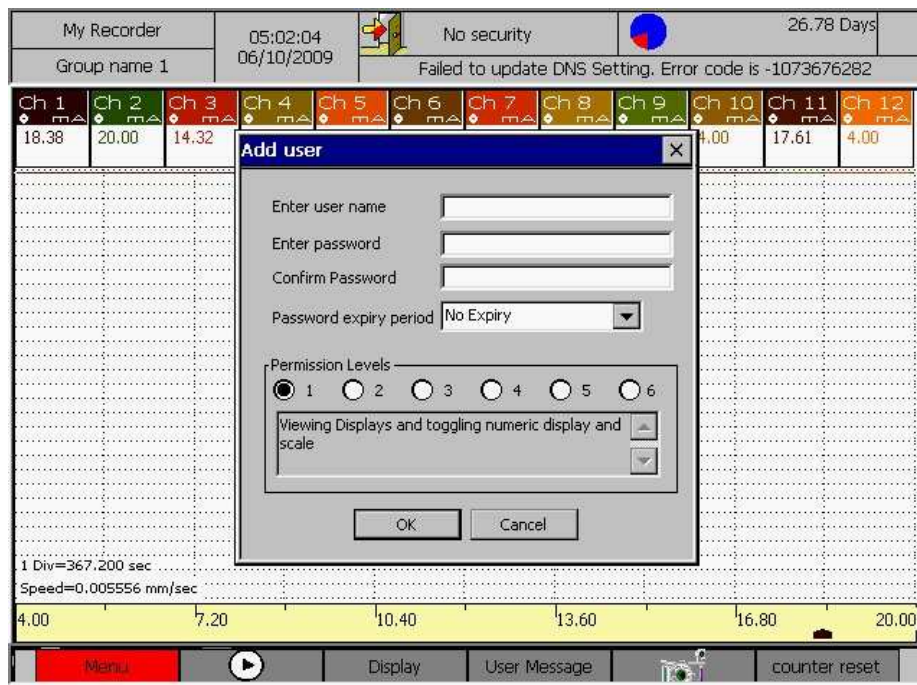

Figure 4. 4: Add User (Contd)

3. Rotate the knob to select the “Enter user name” box and then press the knob to get the onscreen keyboard. Enter the user name and select ENTER in the keyboard to confirm the user name entered.
4. Enter the password and confirm password box in the similar way as explained above.
5. Rotate the knob to the next field which is “Pass Word Expiry Period” combo box. And select password Expiry period for the user.
6. Select the permission level by rotating and pressing the knob.

7. Again rotate the knob to select the OK button. Once the OK button highlighted press the knob to add the user.

**Note: The recorder can have up to 12 users (including master).**

#### **4.1.1.2 View/Edit User**

The view user option provides the list of users from which a user can be selected.

Password Expiry Period:

User can change the password expiry period in this dialog. The expiry period can be 3 months/6 months /9 months /12 months or No Expiry if the user doesn't want any pass word expiry period. Master can only permission to change its own expiry period.

Procedure:

1. Select the Menu→ Basic Configuration→ Authentication→ View/Edit User option
2. Rotate and press the knob to select the user among the generated user's list.
3. Rotate the knob to select OK, DELETE, SAVE or CANCEL. Press the knob to perform the required operation once the corresponding button is highlighted.

Note:

1. User "Master" cannot be deleted.
2. User "Master" permission level cannot be changed.

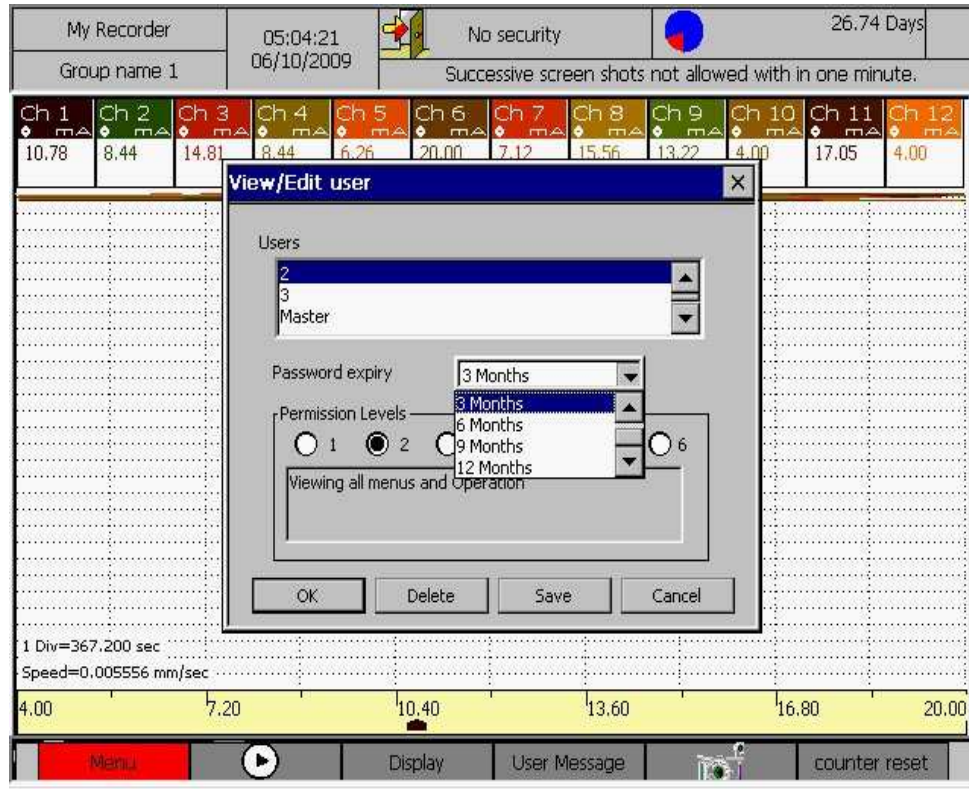

Figure 4. 5: View User

### 4.1.1.3 Enable Login

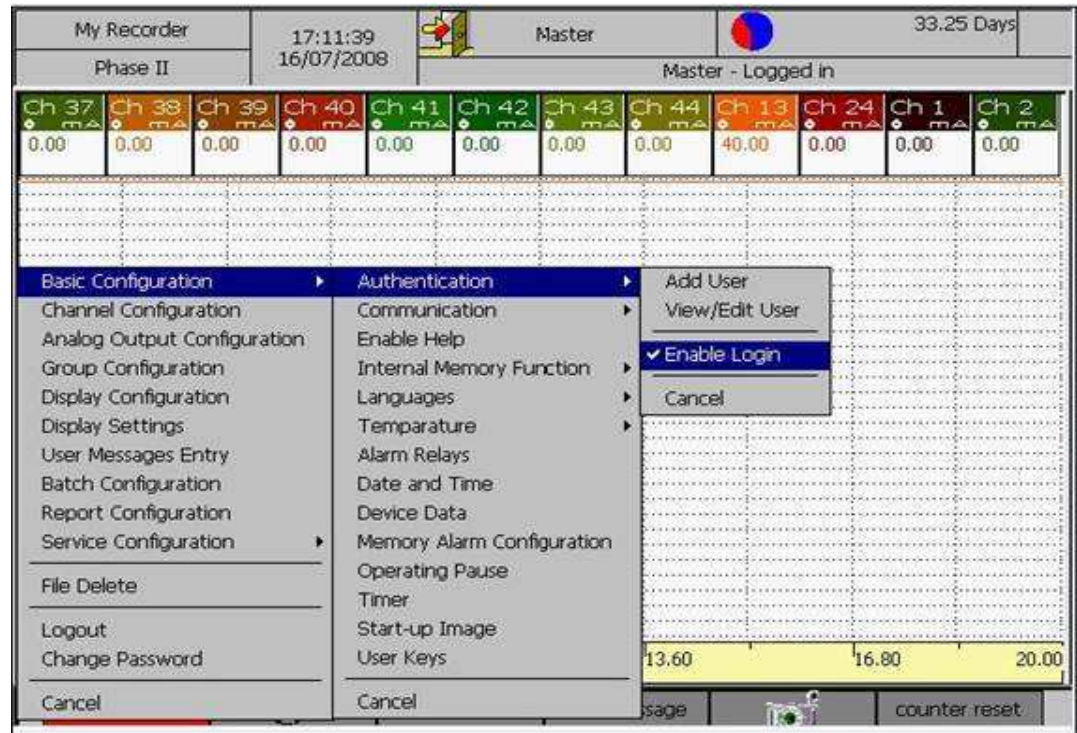

Figure 4. 6: Enable Login

The enable login option allows the user to enable the login process. If “Enable Login” option has a check mark before it, the login window is enabled and vice versa. In case ‘login process’ is disabled, only the master can enable it. In that case, pressing the ‘Enable Login’ Menu item will be followed by a prompt to enter the master password. Enabling the login process will only be confirmed after the correct password has been entered, after which the main screen (group display) will be displayed.

Procedure :

1. Select the Menu→ Basic Configuration→ Authentication→ Enable Login Option
2. Press the knob to check/uncheck the logon option.

**Note:** By default Enable Login is disabled.

### 4.1.2 Communication

This option in the “communication” menu allows the user to configure the MODBUS settings, Ethernet settings, DNS settings, FTP settings, Email settings and Browser application permissions.

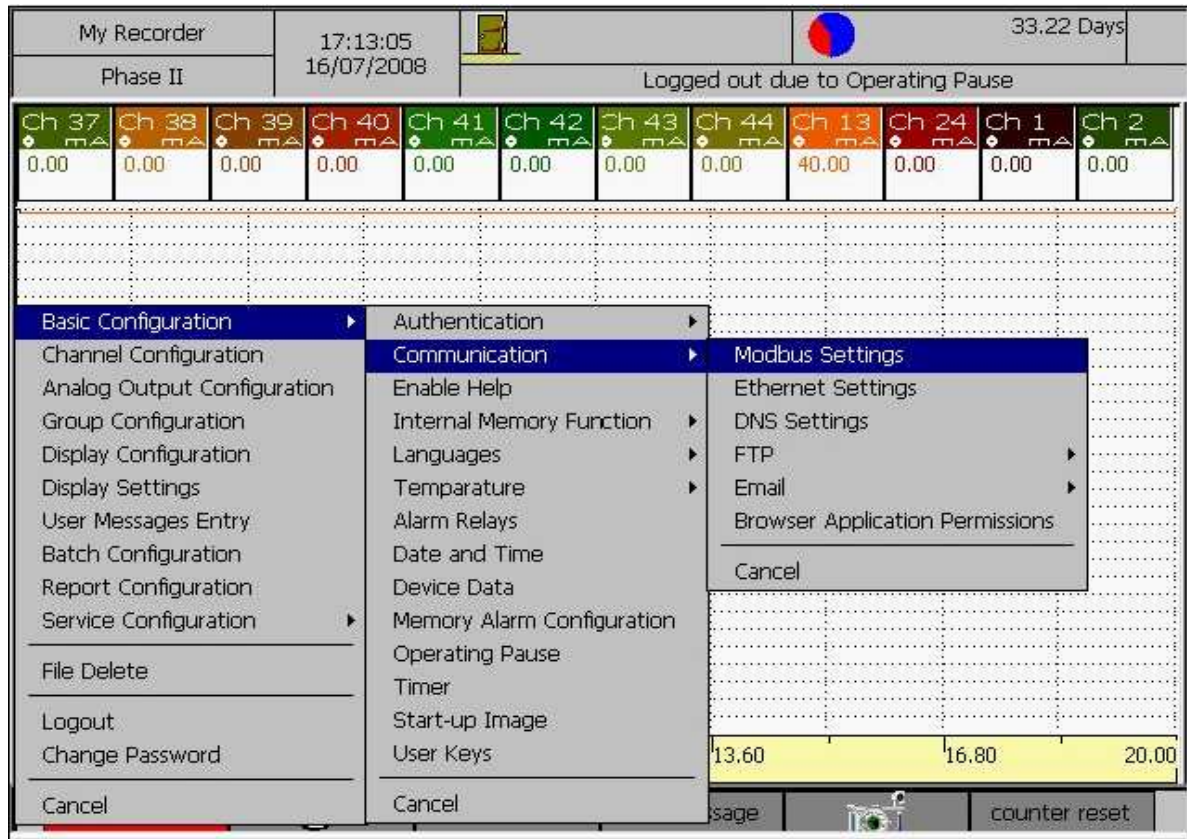

Figure 4. 7: Communication

#### 4.1.2.1 MODBUS Setting

This option allows the user to configure the MODBUS/RTU port by specifying the Baud rate, parity, data length, stop bits and mode of MODBUS operation i.e., Master or Slave. In the Master mode, the external MODBUS/RTU channels of the recorder get enabled, and it queries process values from other slave devices in the MODBUS/RTU network. When recorder is a Master in the MODBUS/RTU network, it need not have an address for itself, so the Slave Field is disabled. If Slave Mode is selected, Operator must specify a slave address for Recorder.

Procedure:

Select the Menu→ Basic Configuration→ Communication→ MODBUS Setting option. The *Modbus Settings* Dialog Box comes up, with default focus on *Baud Rate* field.

**Baud Rate:** Recorder supports standard baud rates of 9600, 19200, 38400, 57600 and 115200. Press the knob to drop down the list of all the available baud rates. Rotate the Knob to select the desired baud rate. Again Press to confirm the selected baud rate. Again rotate the knob to move to the next field.

**Data Length:** Recorder supports two data lengths-7 bits per frame or 8 bits per frame. Press the knob to drop down the list of all the available data length options. Rotate the Knob to select the



desired data length. Again Press to confirm the selected data length. Again rotate the knob to move to the next field.

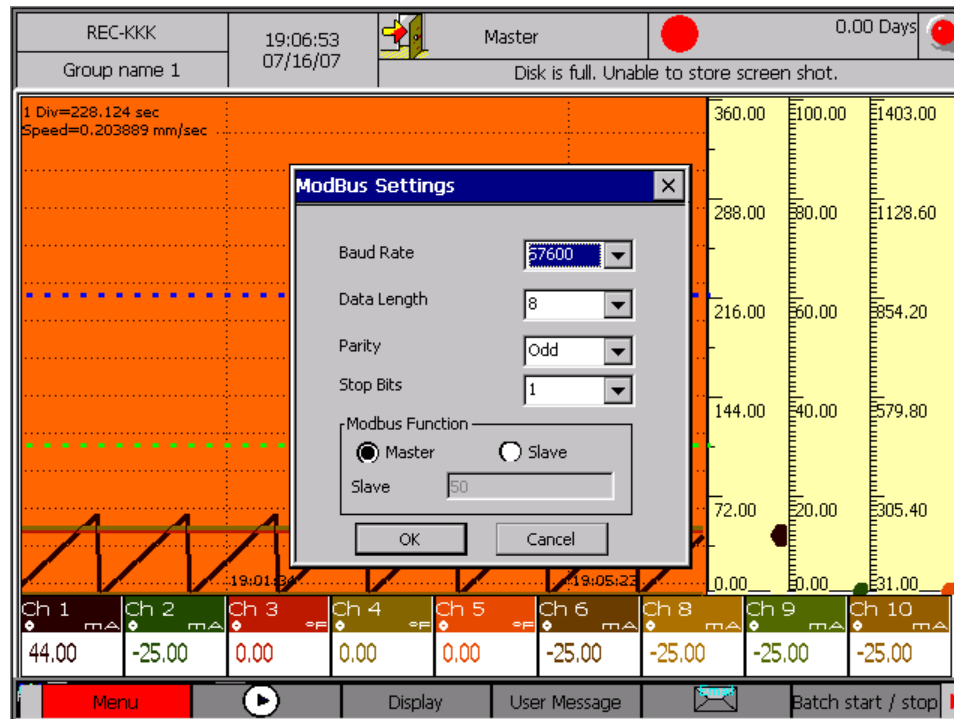

Figure 4. 8: MODBUS Setting

**Parity:** Recorder supports three types of parity checks for serial data framing-Even, Odd and None. Press the knob to drop down the list of all the available parity options. Rotate the Knob to select the desired parity. Again Press to confirm the selected parity. Again rotate the knob to move to the next field.

**Stop Bits:** Recorder provides two options for number of Stop Bits for serial data framing-one or two. Press the knob to drop down the list of all the available stop bits options. Rotate the Knob to select the desired number of stop bits. Again Press to confirm the selected number of stop bits. Again rotate the knob to move to the next field.

**ModBus Function:** Recorder may be configured as Master in the MODBUS/RTU network, or as Slave. Recorder must be configured as Master, if external MODBUS/RTU channels have to be operational, so that recorder queries process values every 1 second to fetch data from slaves in the network. If recorder is configured as Slave, it cannot fetch data for the MODBUS/RTU channels. Instead, Recorder behaves as a MODBUS /RTU slave with a specified address, to which external Master in the network can post MODBUS/RTU queries as per the addressing scheme specified in the Recorder MODBUS/RTU Address Map. All the important Recorder parameters are available in the Recorder's MODBUS/RTU Address Map (Refer 11.1 RECORDER MODBUS/RTU ADDRESS MAP for details). Rotate the knob to select 'Master' or 'Slave'. If Slave is selected,

Edit box to enter recorder slave address gets enabled. Rotate the knob to go to the edit box and using the virtual keyboard, enter the slave address that can be anything between 1 through 254.

Again turn the knob to move to OK or CANCEL. Press the knob on OK to confirm your changes and press CANCEL to exit from the Modbus Settings dialog without saving your changes.

#### 4.1.2.2 Ethernet Settings

The Ethernet settings have to be entered in order to use the Ethernet communication functionality of the recorder. The setting can be done via DHCP or it can be entered directly by selecting the 'Specify IP Address' option. If DHCP is selected none of the parameters have to be entered.

The parameters to be entered are:

1. **IP Address:** It consists of four numerical values (0 to 255), each separated by a DOT (.) For example, 192.168.6.214. If the IP address of the device is not set the browser tool can't be able to establish the connection. While using the browser tool if the IP address of the device is changed then, the browser will stop working.
2. **Subnet Mask:** Format of the Subnet mask is same as the IP Address. This address identifies the network in which recorder is situated.
3. **Gateway:** This address identifies the router, which is used to communicate with the other network. Gateway address format is same as IP address.

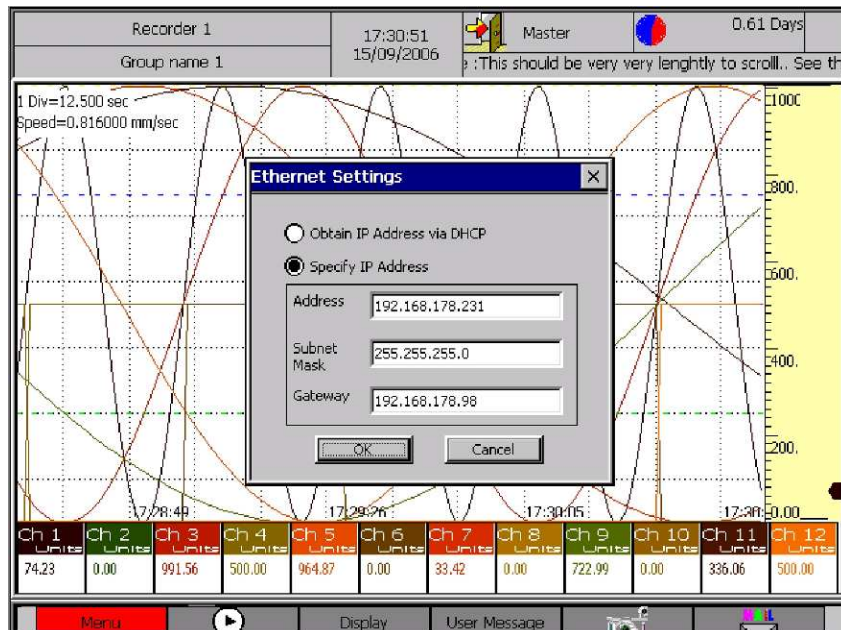

Figure 4. 9: Ethernet Setting

Procedure:

1. Select the Menu option in the short cut bar.
2. Select the Basic Configuration submenu.
3. In Basic Configuration submenu select the Communication submenu.
4. Select Ethernet settings in the Communication submenu and the dialog box shown in figure 13 will be displayed.
5. By default the option to obtain the IP Address via DHCP is enabled. If the recorder cannot obtain an IP Address from the DHCP server or locate a DHCP Server, it will check for a DHCP server every 5 minutes until a server is located.
6. To disable the default option turn the knob until the next option comes into focus. Press the knob to select that option.
7. Then turn the knob until the focus shifts to the Address box. Press the knob for the keyboard to be displayed. Enter the IP address.
8. Turn the knob until the focus shifts to the Subnet mask box. Enter the Subnet mask as described above.
9. Enter the Gateway as described above. After entering the values rotate the knob until the focus shifts to the 'OK' button.
10. To save the settings click on the 'OK' button, else click on the 'Cancel' button.

#### **4.1.2.3 DNS Settings**

DNS translates the domain name to IP address. To set the DNS you have to enable DNS and enter the following details:

1. **DNS Server Setting:** Up to two sever IP address can be entered (primary and secondary). If primary is down the secondary server will search the domain name and IP address.
2. **Host Name:** Recorder's host name. It can be up to 25 characters in length.
3. **Domain Name:** It's the network name to which recorder belongs. It can be up to 50 characters in length.
4. **Domain Suffix:** If the IP address of the domain name is not found on the DNS server then the domain name specified in primary and secondary of the domain suffix is searched.

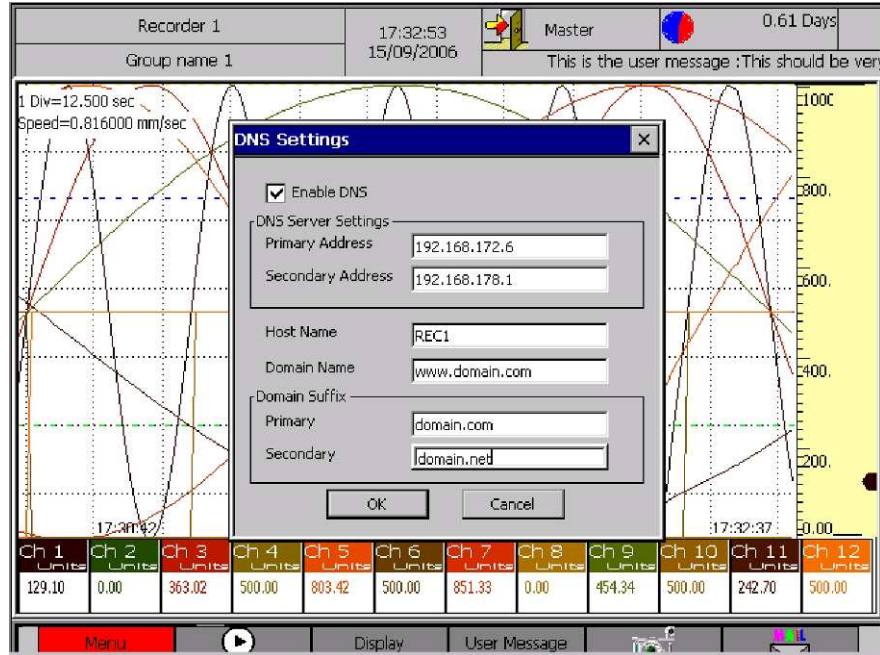

Figure 4. 10: DNS Setting

#### Procedure

1. Select the Menu→ Basic Configuration→ Communication→ DNS Settings option.
2. Go to primary address of the DNS server setting by rotating the knob and press the knob to get the keyboard. Enter the IP address for primary DNS server.
3. Follow the above procedure to enter the secondary server address.
4. Rotate the knob for the Host name. You can enter an alphanumeric name using the keyboard.
5. Enter the domain name and primary-secondary domain suffix using the above procedure.
6. To activate and save the settings go to “OK” and press the knob.

#### 4.1.2.4 FTP

This option allows you to configure the recorder as a FTP Client as well as configure automated FTP uploads.

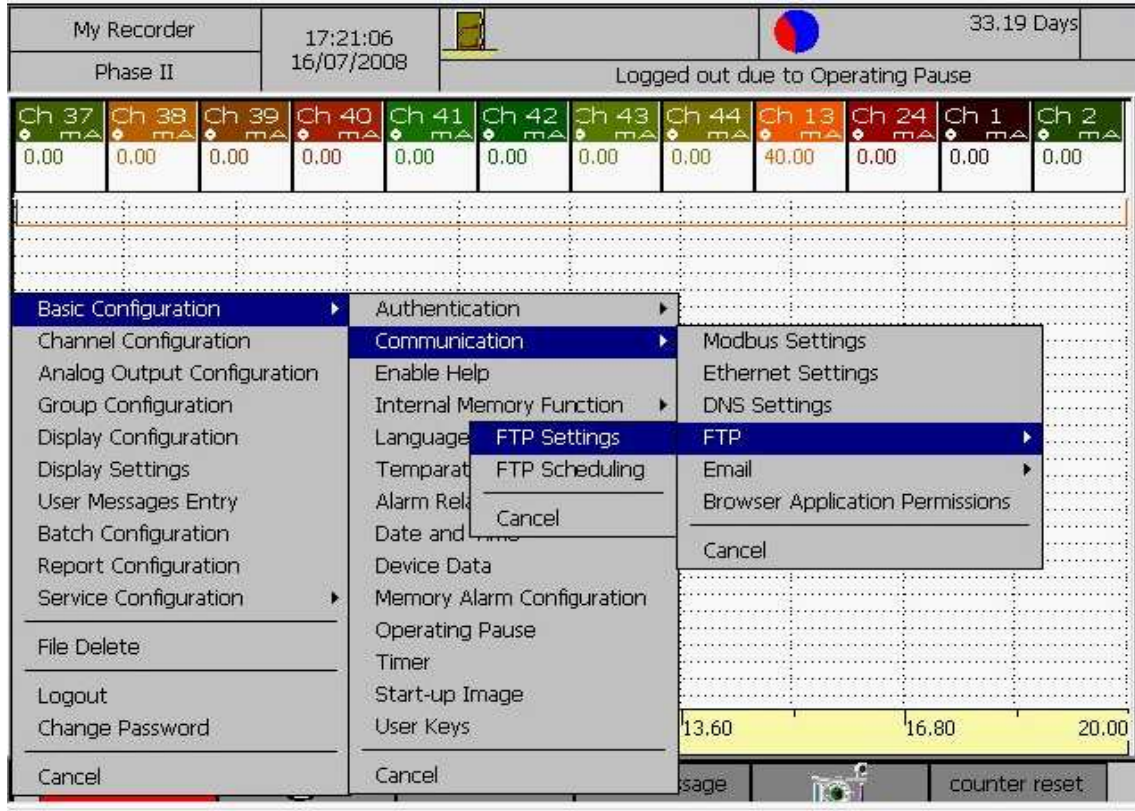

Figure 4. 11: FTP

#### 4.1.2.4.1 FTP Settings

1. **FTP Server Address:** It is a four number address ( 0 to 255) each separated by a DOT (.).
2. **Login Name:** Login name to access FTP. It can be an alphanumeric. It should be an existing log name, i.e. the login name, password and the corresponding account should be created in the FTP Server before using it. It can be 16 characters long.
3. **Password:** Password required accessing the FTP Server. It can be 10 characters long.
4. **Port Number:** Port number can range from 1 to 65535. The default port number is 21.
5. **PASV:** To be checked if the router is having a firewall.
6. **Directory:** Home directory in the FTP Server. The files will be uploaded to the home directory. If a directory other than the home directory is specified, that directory will be created in the root directory in the FTP Server. If a path is provided then all the directories specified in the path, which doesn't exist, will be created. The directory name can be up to 255 characters long. When the path is specified, the directories/folders should be separated by '\'. For e.g.:- DanCon\PaperlessRecorder\
7. **Test:** Allows you to test the settings by connecting to the FTP Server using the Login Name and Password provided. You can also upload files to the directory specified in the

Directory field. Test and User Key FTP are similar. For more information refer User Key – FTP.

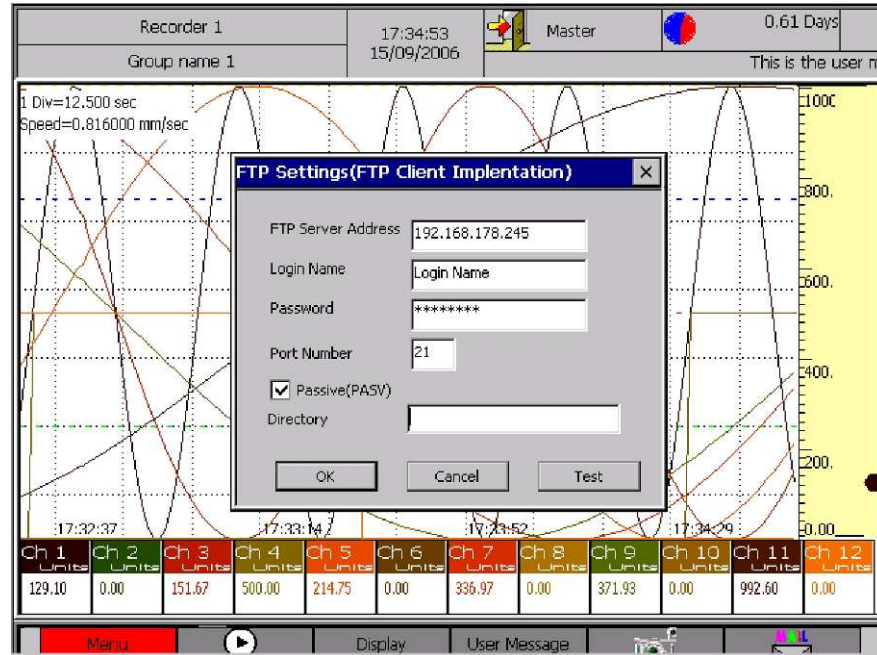

Figure 4. 12: FTP Setting

Procedure:

1. Select the Menu→ Basic Configuration→ Communication→ FTP→ FTP Setting option.
2. Rotate the knob to go to the FTP server address and press the knob for the keyboard. Enter the IP address using the onscreen keyboard.
3. Use the above-explained procedure to enter the login name, password, port number and directory name.
4. Rotate the knob and select OK and press the knob to activate and save the settings.
5. To test the settings click on the ‘Test’ button.

#### 4.1.2.4.2 FTP Scheduling

To schedule a file upload via FTP this option is used. To schedule the file upload

1. Select the data type/file type to upload. Available file types are Historic Data (Historic Group Files), Screen Shots, Batch Files and Reports. You can select any combination of these file types to upload. If no Data types are selected, there will be no FTP uploads.
2. Select the time settings as any of the following: -

- Fixed Time – It is to upload the file every day at a fixed time. The Hours value ranges from 0-23 and the Minutes value ranges from 0-59. Neither of these boxes should be left empty. At least a value of zero is to be entered.
  - Interval - This option is to upload files after a specified time interval.
  - Selected Days – This option is to upload files on the checked days.
3. Check this option to upload files when an alarm occurs.
  4. Check this option to delete files that have been successfully uploaded to the FTP Server.

The recorder uploads the files to the home directory specified in the FTP Settings. If all the files in the recorder have already been uploaded, No FTP Upload shall take place when the scheduled time is reached. The same is the case for upload on alarm.

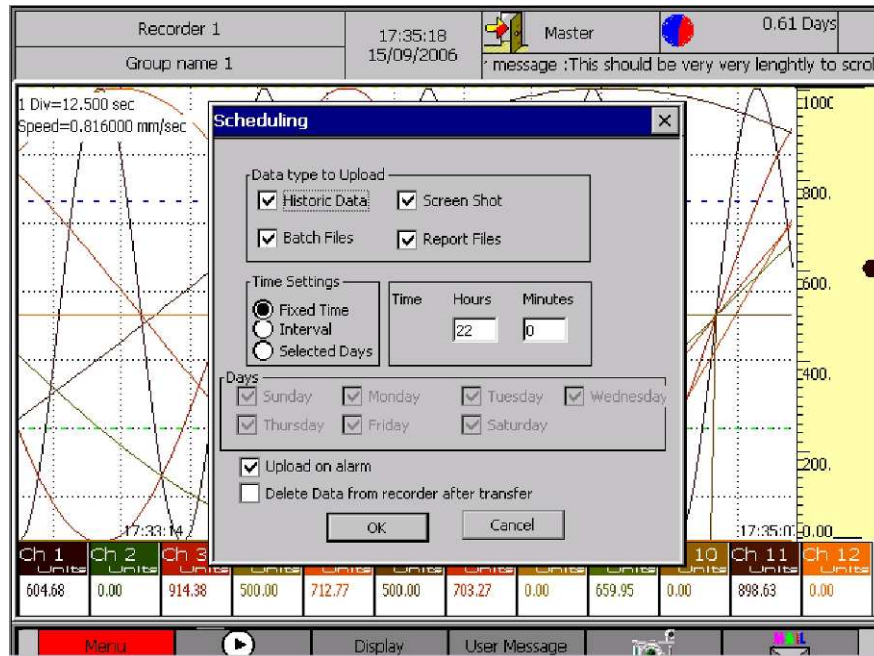

Figure 4. 13: FTP Scheduling

Procedure :

1. Select the Menu→ Basic Configuration→ Communication→ FTP→ FTP Scheduling option
2. Select the data type to upload by rotating and pressing the knob.
3. Schedule the FTP upload using the time setting section.
4. Enter the values for Hours and Minutes using the keyboard.
5. Check 'Upload on alarm' to upload files when there is an alarm.

Note: In case of alarm occurring more than once in a minute, files will be uploaded after one minute if they are available.

6. Check 'Delete data from recorder after transfer' if you want to delete the files that has been successfully uploaded to the server.
7. To activate and save the settings click on the 'OK' button else click on the 'Cancel' button.

#### 4.1.2.5 Email

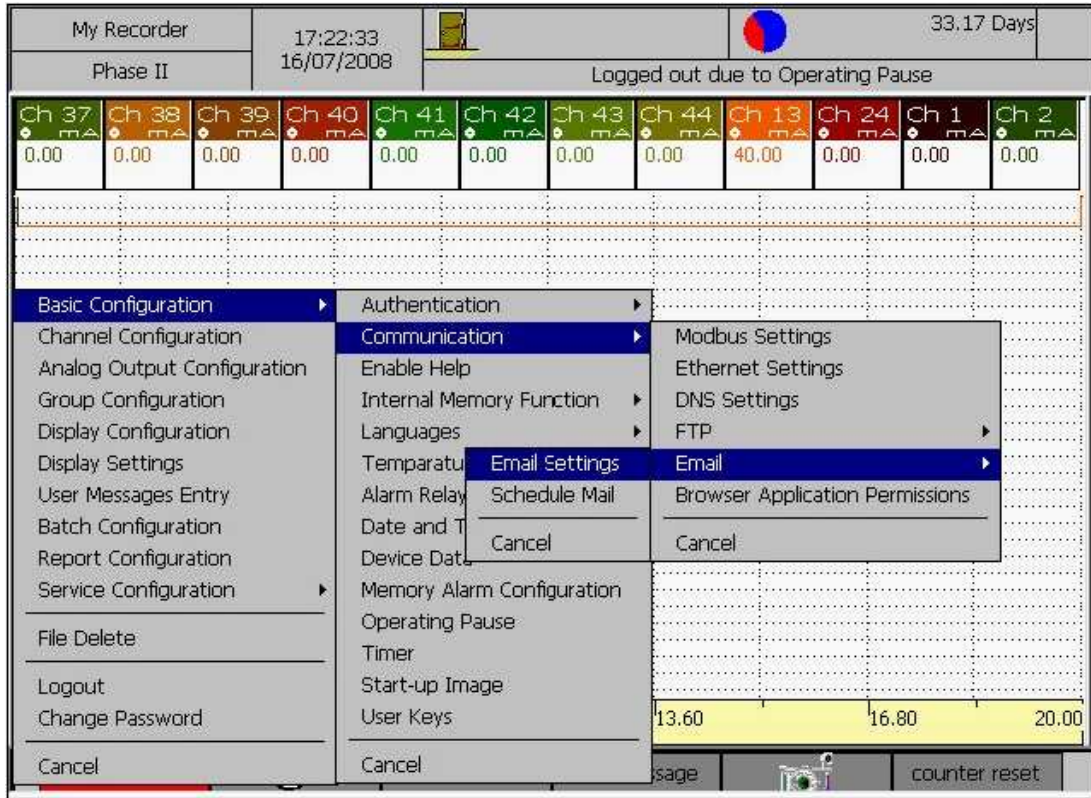

Figure 4. 14: E-mail

This option allows you to configure the recorder for sending automated e-mails. As well as to send emails from the User –Keys in the 'Short Cut Bar'.

##### Procedure

1. Select the Menu→ Basic Configuration→ Communication→ Email option

##### 4.1.2.5.1 Email Settings

These settings allow Recorder to send e-mails.



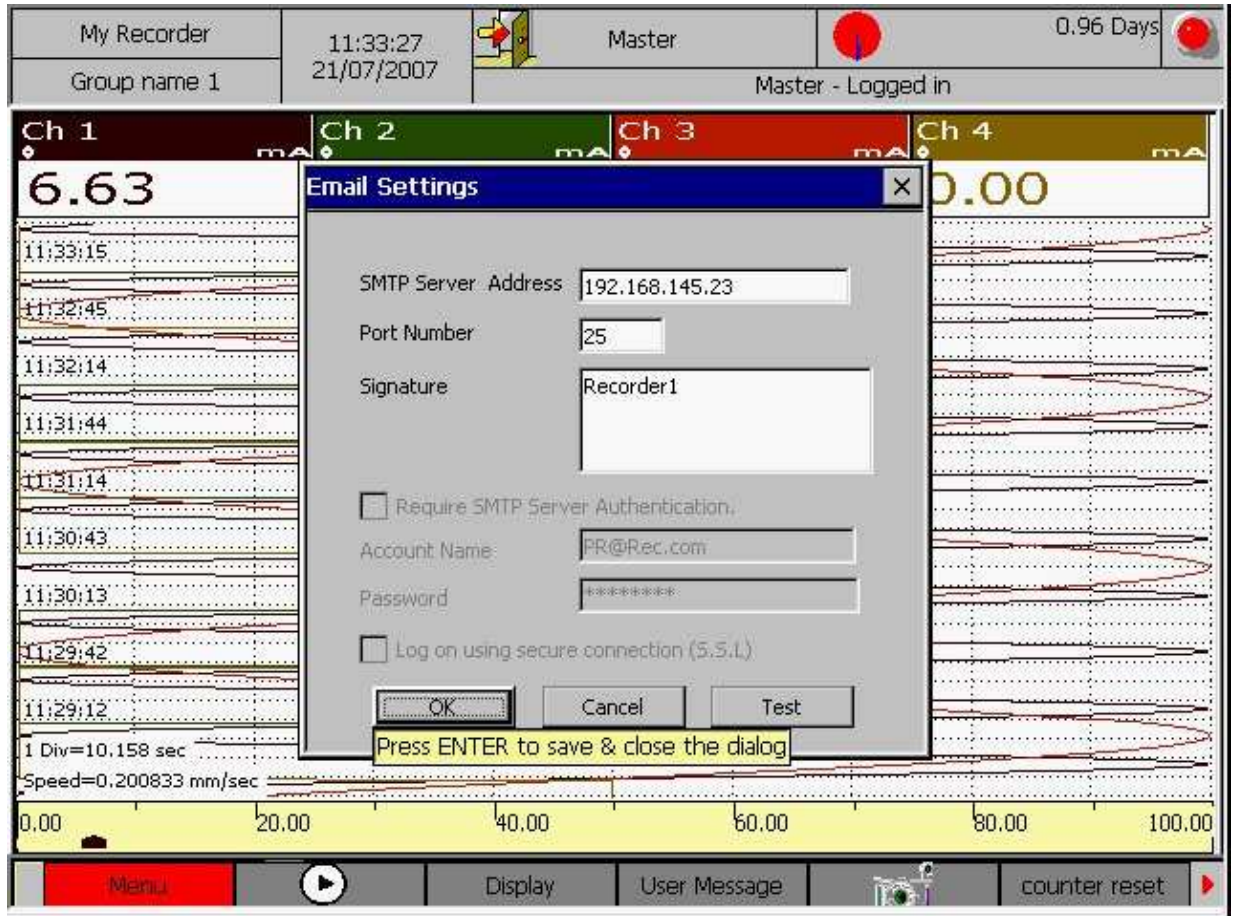

Figure 4. 15: E-mail Setting

1. **SMTP Server Address:** IP address of the SMTP server/ Mail server. Default IP address is 1.1.1.1.
2. **Port Number:** Port Number that is to be used for communicating with the server. Default value is 25.
3. **Signature:** String that is to be added at the end of the e-mail message, as the Signature of the recorder. The signature can be up to 25 characters long.
4. **Account Name:** Account name or login name that is to be used when connecting to the SMTP Server. The account name can be up to 16 characters long.
5. **Password:** Password that is to be used when connecting to the SMTP Server. The password can be up to 10 characters long.
6. If the SMTP Server requires authentication select the **'Require SMTP Server Authentication'** option.

7. To enable Secure Socket Layer (S.S.L) check the option '**Log on using secure connection (S.S.L)**'.
8. '**Test**' button allows you to test the settings by sending an email to any valid e-mail id. Attachments can also be added to this e-mail. The test button is similar to the User Key – Email. Refer to User Key – Email for more information.

Settings 4 to 8 are not available in the current version of the recorder.

Procedure :

1. Select the Menu→ Basic Configuration→ Communication→ Email→ Email Setting option.
2. Rotate the knob to go to SMTP Server Address box and press the knob to get the onscreen keyboard. Enter the IP address using the keyboard displayed on the screen.
3. Similarly enter Port Number, Signature, Account Name and Password.
4. Rotate the knob to set it to OK button and press the knob to activate and save the setting.
5. To test the setting click on the 'Test' button. This button has to be clicked before clicking on the 'OK' button. Subsequent method of sending an email via TEST BUTTON and EMAIL USER KEY are both similar. Refer description for EMAIL USER KEY for further details.

#### **4.1.2.5.2 Schedule Email**

This option allows you to schedule an automated email.

1. **Recipient Address:** Recipient's mail Id is to be entered here. Up to 5 addresses can be entered each separated by a comma (.). The total number of characters acceptable in this field is 250.
2. **Subject:** Subject of the e-mail. In the case of alarms, for identification purpose the text 'Email on Alarm:' is added to the subject. The total number of characters acceptable in this field is 25.
3. **Message:** Message of the e-mail. The total number of characters acceptable in this field is 100.
4. **Data Type:** The file types that is to be sent as attachments with the email. The file types are Historic Data (Group Historic Files), Batch Files Standard Report and Screen Shot. If no file types have been selected for emailing, no emails will be sent.
5. **Time Setting:** The time at which the mail is to be sent. This has the following options: -
  - Fixed Time, i.e., the email is to be sent every day at the specified time. The Hours values range from 0-23 and Minutes value range from 0-59.

- Interval, i.e., the email is to be sent every time the specified time interval is over.
  - Selected Days, i.e. the email is to be sent only on the checked days.
6. If the 'Email on Alarm' option is checked, e-mail with attachments is sent when an alarm occurs.
- Note: In case an alarm occurs more than once in a minute only one email will be sent.
7. If “**Delete data from recorder after transfer**” is checked, the files that have been sent as attachments with the e-mail are deleted if the email is successfully sent.
8. ‘**Maximum attachment size allowed via schedule**’: This option is to specify the maximum file size that the recorder can send as attachments. The recorder can send up to 6 MB as attachments. The recorder can send up to 10 files as attachment with an email. This number depends on the file size. For example if each file has a size of 2 MB and if ‘**Maximum attachment size allowed via schedule**’ is specified as 6MB, then the email will have only 3 attachments.

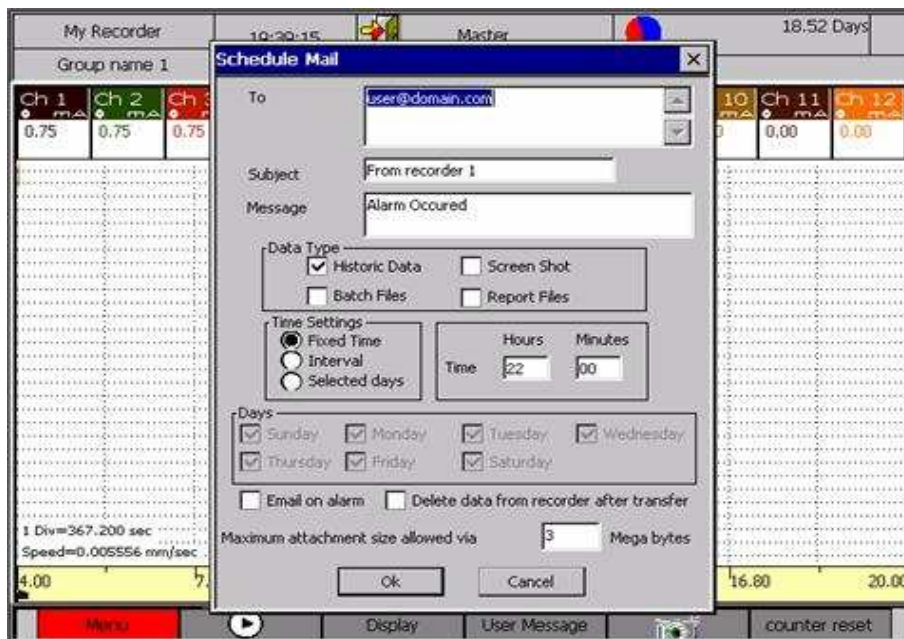

Figure 4. 16: E-mail Scheduling

In the case of automated emails if there are no files to send, then no emails will be sent. If all the files in the recorder have been sent as attachments in the previous emails then no new emails shall be sent. For each email successfully sent there will be entries in the email log. Like wise for each failure there will be entries in the email log.

**Note:** If more than 10 files (Historic files, Report files, Batch files) in recorder memory and Email is scheduled for “Fixed Time” or “Interval” or “Selected days” then Recorder sends more than one mail to corresponding ID.

Procedure:

1. Select the Menu→ Basic Configuration→ Communication→ Email→ Schedule mail option.
2. Rotate the knob until the “**To**” box is highlighted. Press the knob to display the keyboard on the screen. Enter the recipient email Ids using the keyboard.
3. Similarly enter the subject and message using the onscreen keyboard.
4. Rotate the knob until the first data type ‘Historic Data’ is highlighted. Press the knob to check, else rotate the knob to the next option.
5. Rotate the knob to enter the time setting section. Rotate the knob till the required setting is highlighted. Press the knob to select. For ‘Fixed Time’ and ‘Interval’ values are to be provided in the Hours and Minutes boxes respectively. Neither of these boxes can be left empty; at least a zero is to be entered. Rotate the knob to check the days for ‘Selected Days’.
6. Check ‘Email on Alarm’ if e-mail is to be sent on an alarm.
7. Check ‘Delete data from recorder after transfer’ if files are to be deleted from the recorder after successfully sending them as e-mail attachments.
8. Specify the size limit for attachments in the ‘**Maximum attachment size allowed via schedule**’ box using the keyboard displayed on the screen.
9. Click on the ‘OK’ button to save the new settings, else click on ‘Cancel’ button.

### 4.1.2.5.3 Browser Application Permissions

This option in the communication allows the user to enable/disable various 'Browser Application' options as shown in the figure 4.17.

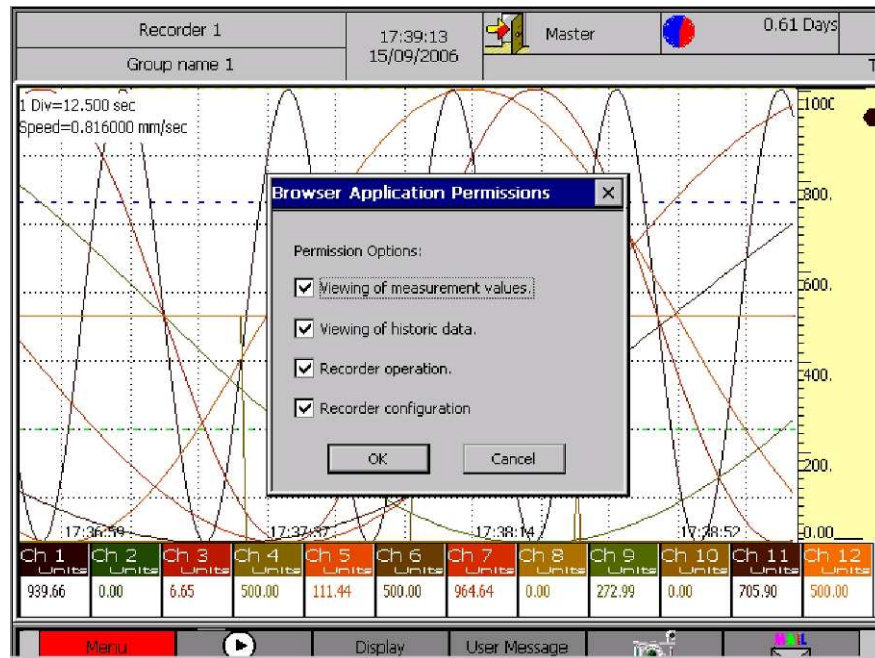

Figure 4. 17: Browser Application Permissions

Procedure:

1. Select the Menu→ Basic Configuration→ Communication→ Browser Application Permissions option
2. Select the desired options by rotating and pressing the knob.
3. Rotate the knob to either select the OK or CANCEL button. Once the desired button is highlighted press the knob to confirm or cancel the changes.

### 4.1.3 Enable Help

Select the Menu→ Basic Configuration→ Enable Help option.

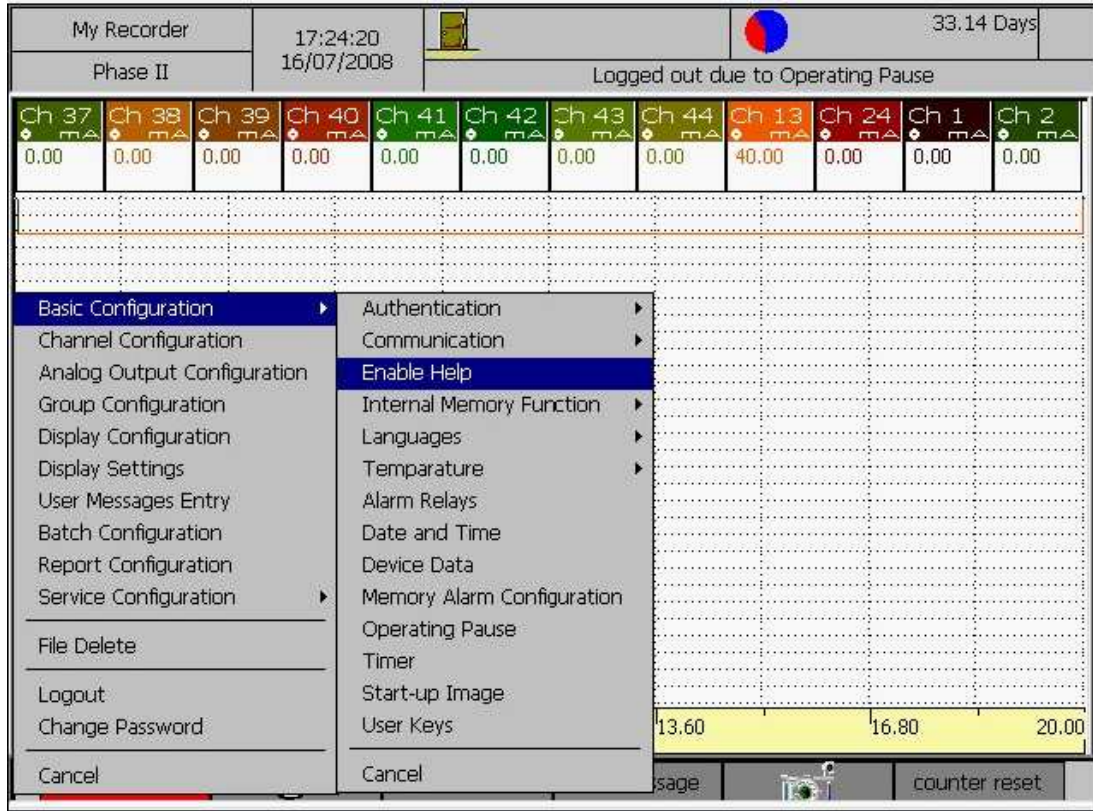

Figure 4. 18: Enable Help

This option allows the user to enable/disable the Help Function.

If Help is enabled then, for each and every dialog the help message will be displayed for 5 seconds.

#### 4.1.4 Internal Memory Function

The memory operation of the recorder can be configured as:

- 1) FIFO (First in first out): In this configuration when the memory is full the older data will get replaced by the new ones and the recording operation won't get stopped, but the top status bar will indicate that the memory is full.
- 2) Stop Recording When Full: In this configuration the recording will automatically stop as soon as the memory gets full.

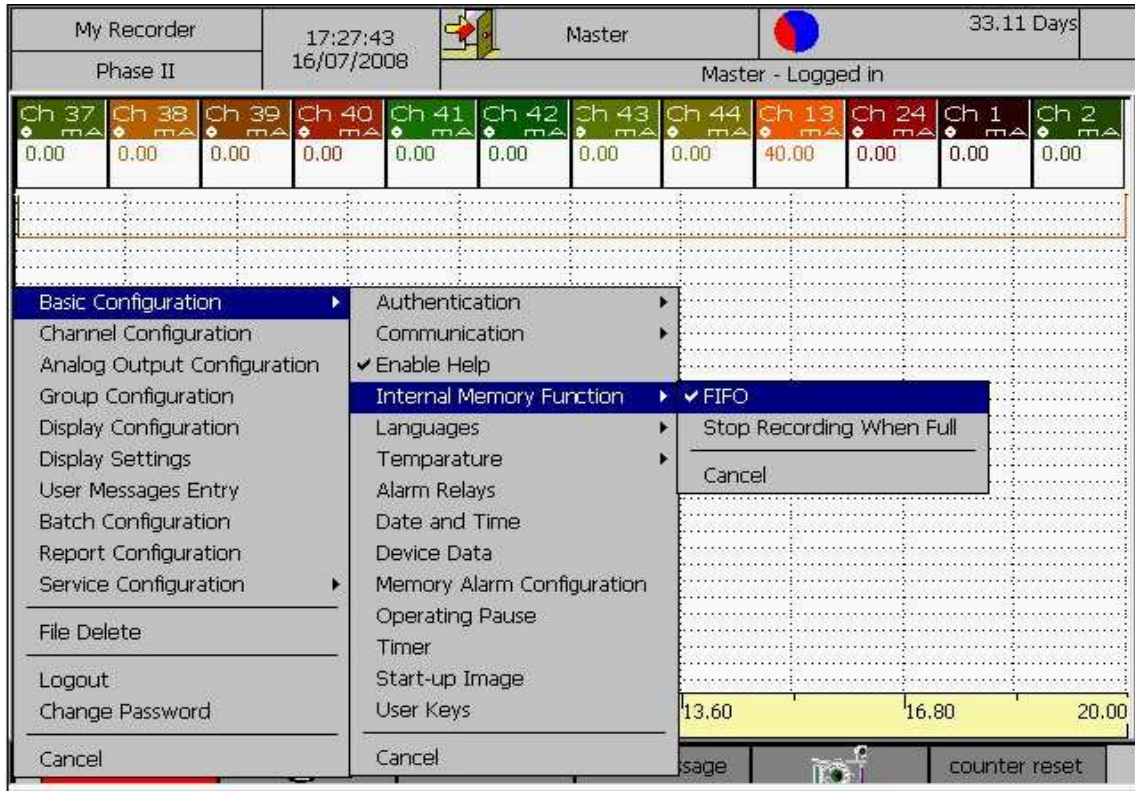

Figure 4. 19: Internal Memory Function

Procedure:

1. Select the Menu→ Basic Configuration→ Internal Memory Function→ FIFO/Stop Recording When Full

#### 4.1.5 Languages

Language for the recorder can be selected using this option. Currently, Recorder supports only English as its operating language.

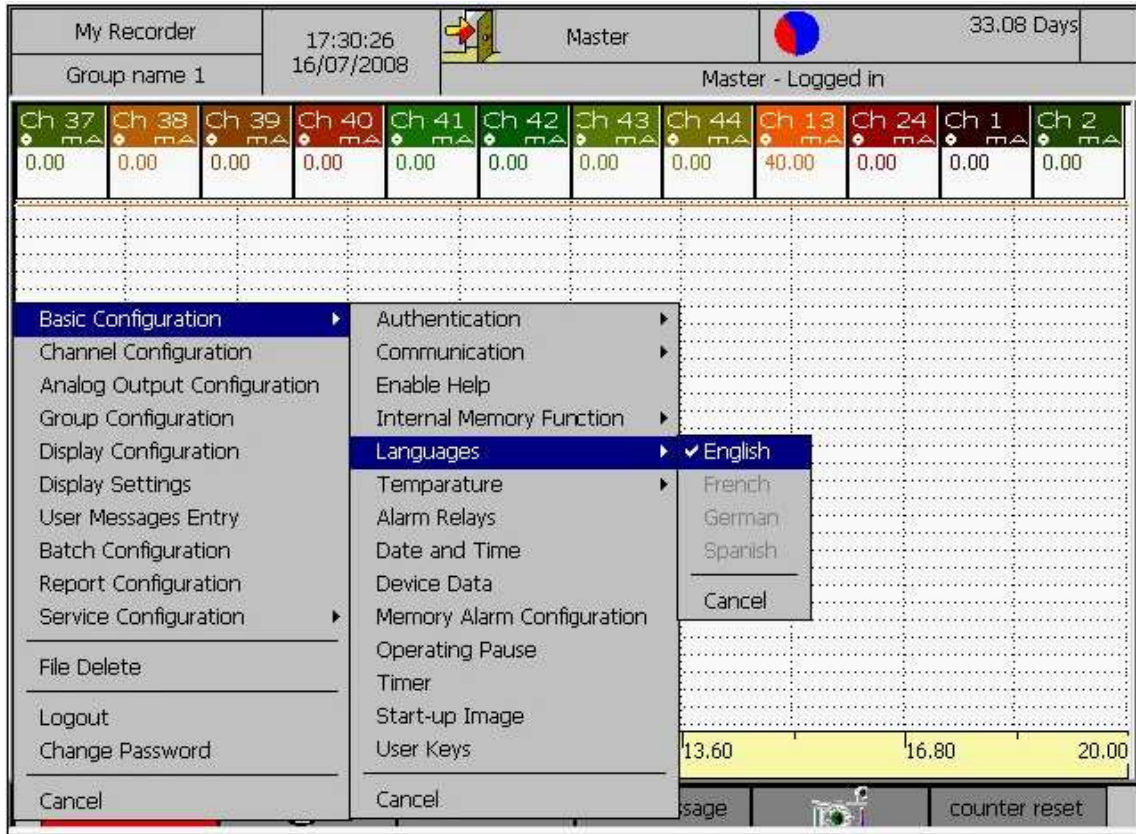

Figure 4. 20: Languages

Procedure:

1. Select the Menu→ Basic Configuration→ Languages option
2. Rotate the knob to highlight the required language and press to the knob to select it.

#### 4.1.6 Temperature

The unit of TC types or RTD types of On-Board channels can be selected by choosing one of the options provided in the sub menu. Once an option is selected a check (✓) mark will appear next to the selected option. The unit of Temperature is applicable for only those On-Board input channels, which are configured as.



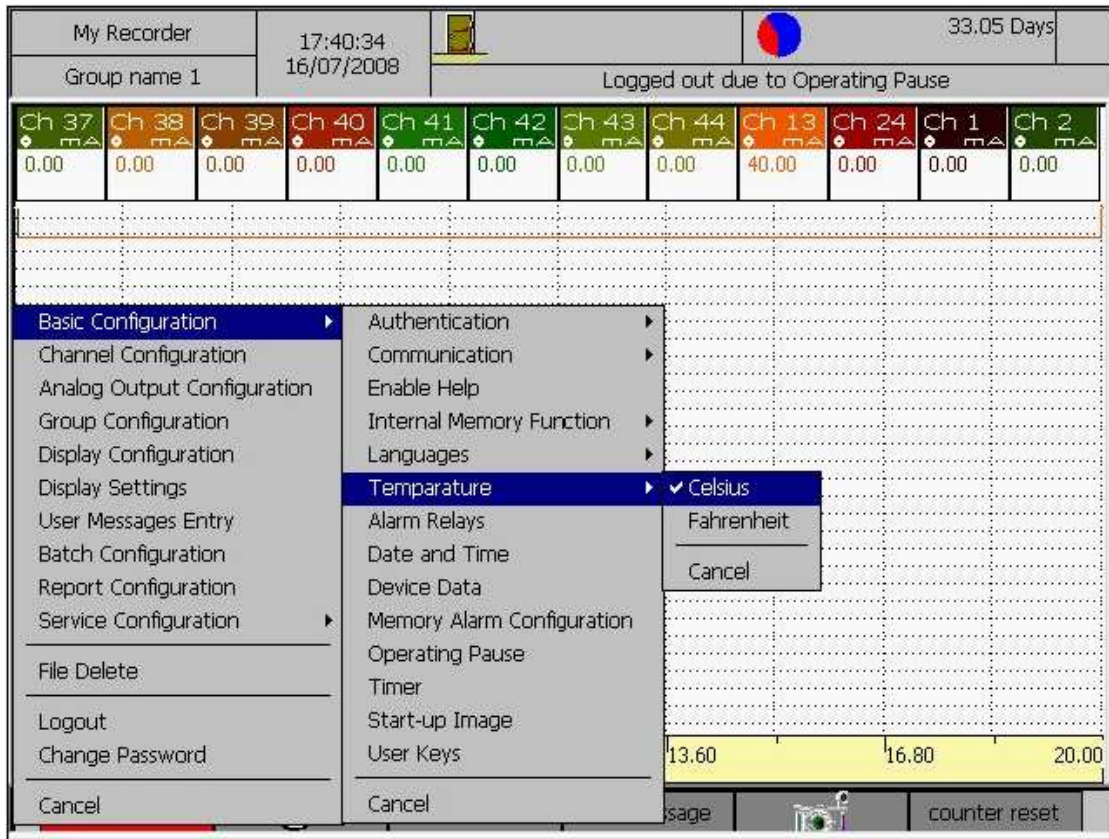

Figure 4. 21: Temperature

Procedure:

1. Select the Menu→ Basic Configuration→ Temperature option.
2. Rotate the knob to highlight the required unit and press the knob to select it.

Note: Changing temperature settings shall RESET all channel data along with the display.

#### 4.1.7 Alarm Relays

Select the Menu→ Basic Configuration→ Alarm Relays

The Recorder comes with 4 configurable alarms per channel. Each of the four alarms for a channel may be associated with an output relay (only if there is any Relay card present in Recorder). The number of output relays available with the Recorder depends on the type of output card installed. An Output card can support four, eight or twelve Output Relays. A maximum of one output card is allowed. The 'Alarm Relays' Dialog box is used to configure response of each relay, whenever it's associated channel alarm occurs.

If your version of recorder has no relays, no relays shall be enabled for configuration in this dialog. Figure 4.22 below shows a recorder setup with 4 relays. If your version has a relay card with four,

eight or twelve outputs, relays 1 through 4, 1 through 8 or 1 through 12 shall be enabled respectively.

The response of a relay may be configured as 'Energize' or 'De-Energize'. If a relay is configured as 'Energize' it turns "ON" with the Alarm and vice-versa.

If configured as 'NonLatch' and 'repeat', the relay keeps toggling every 1 second during the alarm state, then goes to it's "ON" or "OFF" state, depending whether it's set as 'Energize' or 'De-Energize'.

If 'NonLatch' and 'non-repeat' ('repeat' option is not checked), it gives a single pulse of 1 second at the start of alarm, and becomes ON or OFF, depending whether its 'Energize' or 'De-Energize' respectively.

Note: A relay may get associated with more than one alarm from same or different channels as well as memory alarm (discussed in section 4.1.10). In such a case, relay shall get activated with the start of any one of the associated alarms, and shall remain in activated state until no associated alarm is persistent anymore.

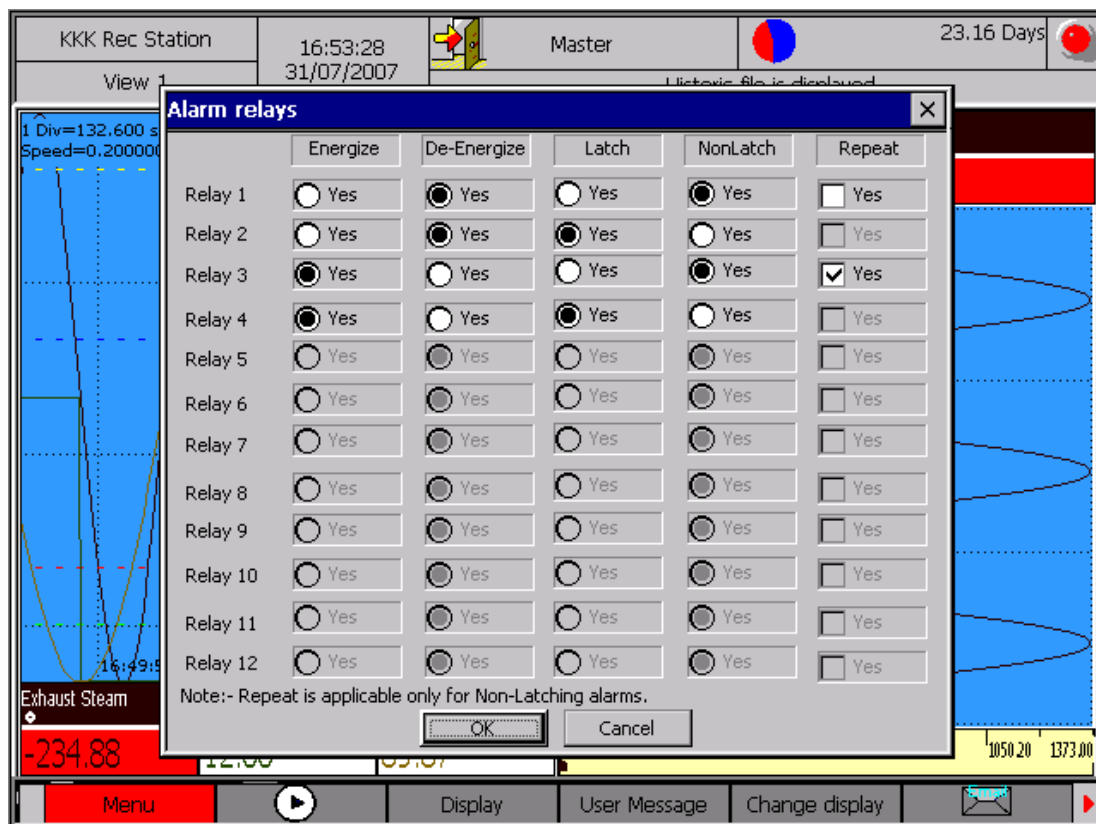

Figure 4. 22: Alarm Relays

### 4.1.8 Date and Time

Procedure:

1. Select the Menu→ Basic Configuration→ Date and Time option.
2. **Date Display Format:** Anyone of the format can be selected among the given six formats. Format can be selected by rotating the knob.
3. **Enable Time Server:** Check the box to set the recorder time via timeserver.
4. **Time Server IP:** By pressing the knob at IP address and port number box respectively user can enter IP address and port number.
5. **Set Date and Time:** If “Enable time Server” is unchecked, user has to enter the date and time for the recorder. By rotating and pressing the knob at the corresponding boxes user can enter date and time.
6. **Enable Daylight Saving:** Check it to enable the daylight setting section.

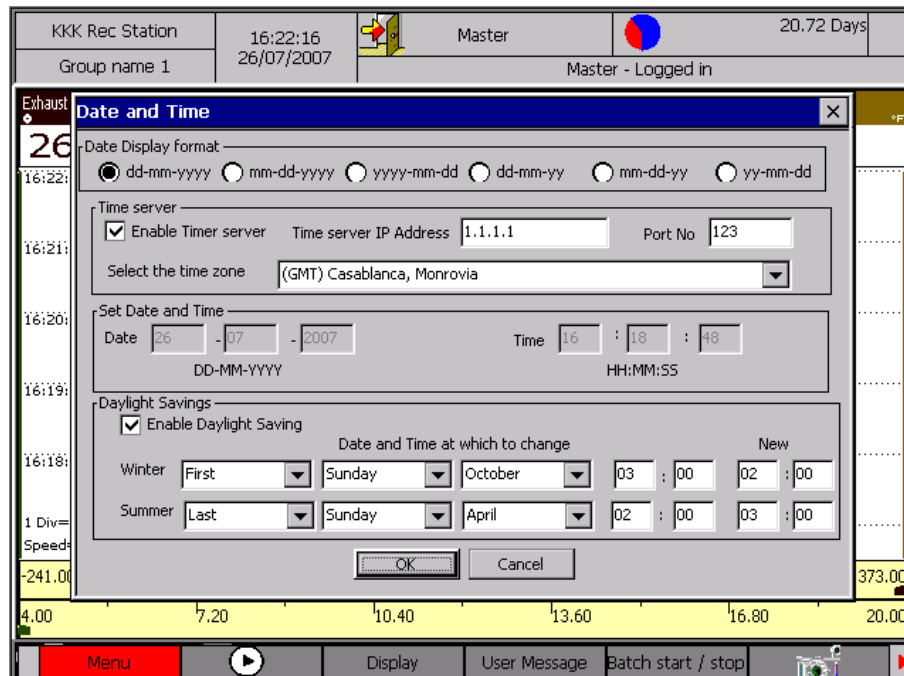

Figure 4. 23: Date and Time

#### NOTE:

- Recorder shall synchronize the time from timeserver every day at 3AM recorder time. If unable to connect to server for first time, recorder shall try five times and try to synchronize.
- If it is failed for five times then recorder shall log the details in device log.

- Recorder will synchronize the time from timeserver only if the difference is more than one minute.
- If Recording is ON and time is updated due to timeserver synchronization, recording shall be stopped and restarted after time updation automatically.
- The updated time is calculated as follows
  - Time server time (UTC time)  $\pm$  Time zone's difference (From GMT) + Day light saving time (If Daylight saving)

#### 4.1.9 Device Data

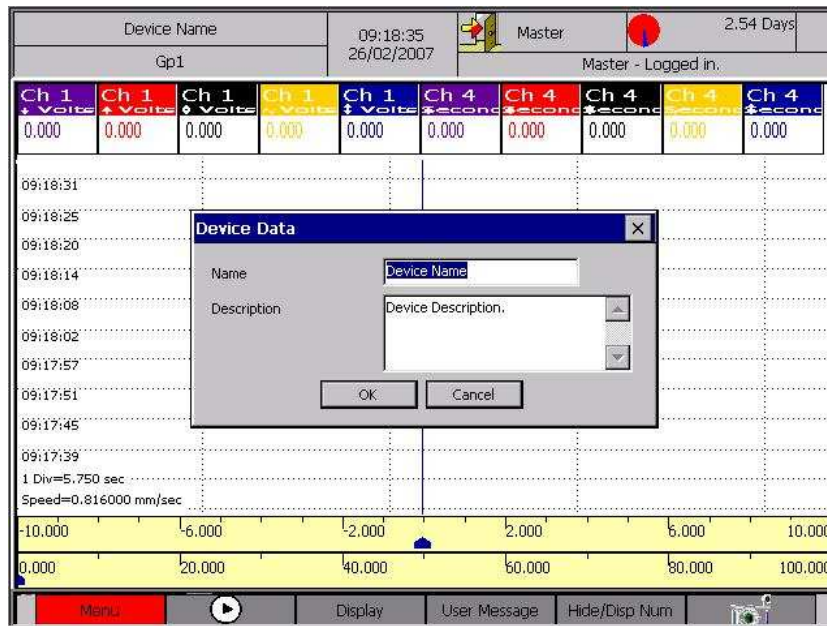

Figure 4. 24: Device Data

By using this dialog, user can set the name (Max 16 characters) of recorder and description (Max 64 characters) of recorder. The name of recorder will be displayed in the status bar.

#### 4.1.10 Memory Alarm Configuration

This option of the Basic Configuration menu allows you to set the unit of memory time (memory time is used to indicate for how long the remaining unused space in the storage medium is sufficient to store data.) in days or hours. The memory related alarm is to be configured here.

1. **Unit of Memory:** The unit of memory can either be 'Days' or 'Hours'. If the 'Days' option is selected then the remaining memory time is calculated in terms of days. If 'Hours' option is selected then the remaining memory time is calculated in terms of hours.
2. **Days/Hours Remaining:** The alarm is triggered when the remaining memory time is less than the entered number of days/hours.
3. **Relay:** If a set of relays is available with your recorder (a relay card with four, eight or twelve output relays must be installed), any one of the available relays

can be associated to be activated whenever memory alarm is triggered. Here, behavior of the relay under alarm condition shall be defined by the Alarm Relays dialog discussed previously in section 4.1.7.

To save the settings click on “OK” button. Default selection is ‘Days’.

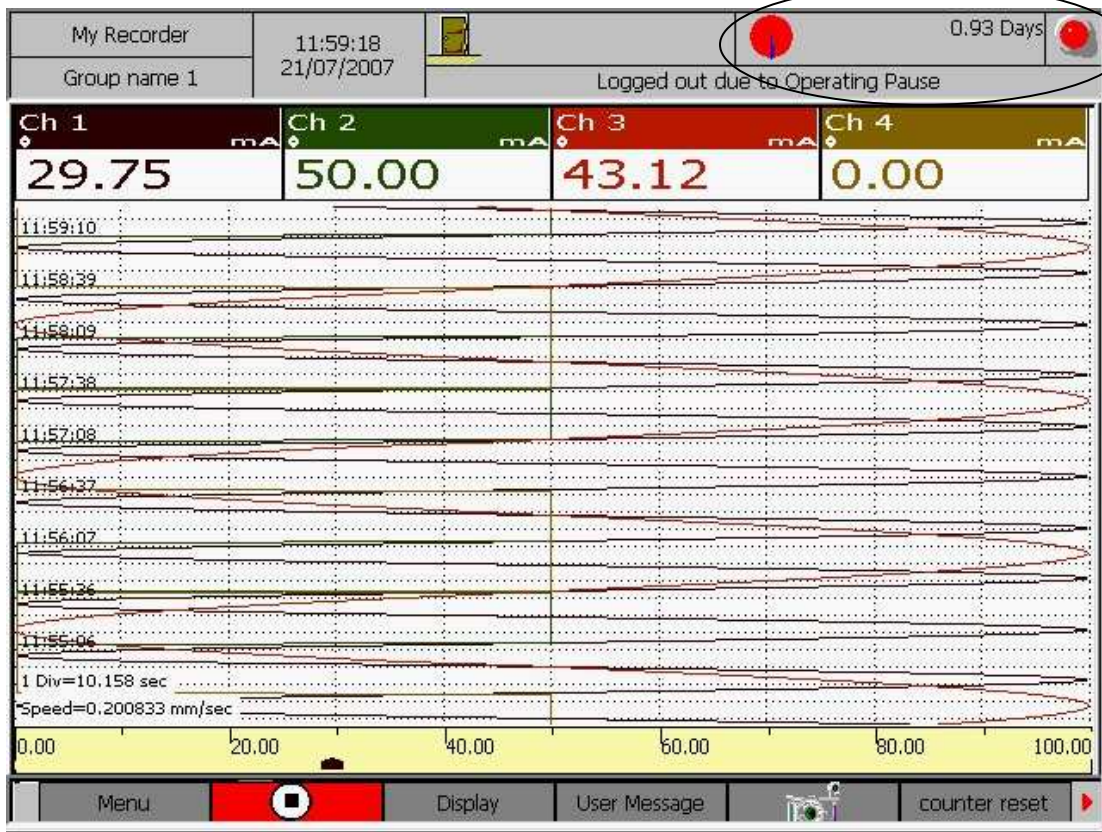

Figure 4. 25: Memory Alarm Configuration

**Procedure:**

1. By default the ‘Unit of Memory’ has the ‘Days’ option selected. To change this selection, rotate the knob to the previous option. Press the knob to select the option.
2. Enter the ‘days/hours remaining’ to trigger an alarm when the remaining memory time goes below the specified days/hours.
3. To associate a relay with the memory alarm, check the ‘Relay’ option and select the Relay from the list.
4. To save and activate the settings select the ‘OK’ button, else select the ‘Cancel’ button.

When there is a memory alarm, an alarm icon will be displayed in top status bar. The remaining memory time is displayed in terms of the selected unit in the Top Status bar (area in the red oval) at all times. When the memory is full the memory icon is completely red. When the memory is empty the icon is completely blue. Memory alarm’s start and stop are logged in the alarm log.

### 4.1.11 Operating Pause

The user can specify the time for which the recorder must remain idle before automatically switching the screen back to the group display. In figure 4.26 below, the screen is configured to automatically switch to group display, if the recorder has been idle for twenty seconds in logged in mode. Once the user tries to use the recorder after the specified operating pause, user will have to login again, if 'automatic logout' and 'Enable login' (Explained in Basic Configuration→ Authentication) are enabled.

Pause time out: It's the recorder idle time after which it has to switch the screen to group display.

Automatic log off on pause: With this option enables user has to re-login after pause time out period.

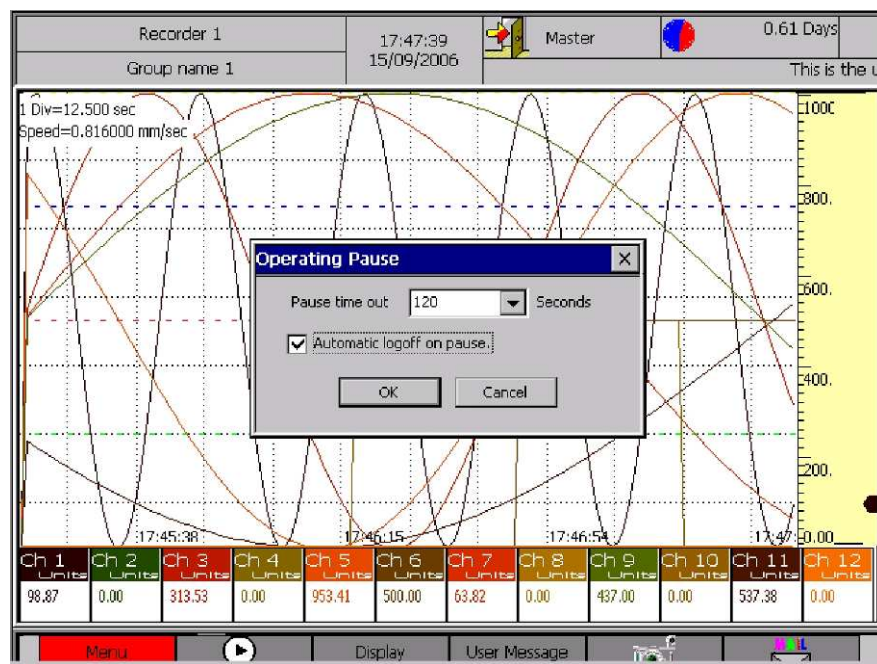

Figure 4. 26: Operating Pause

Procedure:

1. Select the Menu→ Basic Configuration→ Operating Pause option
2. Rotate the knob and select the desired pause time out value. Press the knob to select it.
3. Again rotate the knob and select the automatic logoff on pause box. And press it to check/uncheck the box
4. Rotate the knob to highlight either OK or CANCEL button. Press the knob to select the option once required option is highlighted.

### 4.1.12 Timer

The Recorder offers four configurable timers. Timers may be used to automatically RESET counter channels and calculation channels. Each timer may individually be configured as follows:

*Absolute Timer or Relative Timer:* An Absolute timer starts at a user specified time, and then onwards, triggers repetitively after specified time interval. If the Start time specified for an absolute timer is a history time, then the timer shall start immediately when new setting is confirmed. A Relative timer always starts as soon as new settings are confirmed, and then onwards, triggers repetitively after specified timer interval.

Procedure:

Select the Menu→ Basic Configuration→ Timer

Rotate the knob to switch between the *Absolute* or *Relative* radio buttons. Press the knob when the focus is on the desired type for the current timer, to confirm your timer type. If *Absolute* is selected, again rotating the knob moves the focus to *Start time* column. Press the knob to show the virtual keyboard, and using it, enter the start time. Similarly, you may enter *Time Interval* for timer trigger action (last two columns). Rotating the knob further moves the focus to the timer type selection for the next timer in the next row. From last row corresponding to timer four, rotating the knob moves the focus to *OK* and *Cancel* buttons. Press *OK* to confirm your settings or press *Cancel* to Exit without saving the changes.

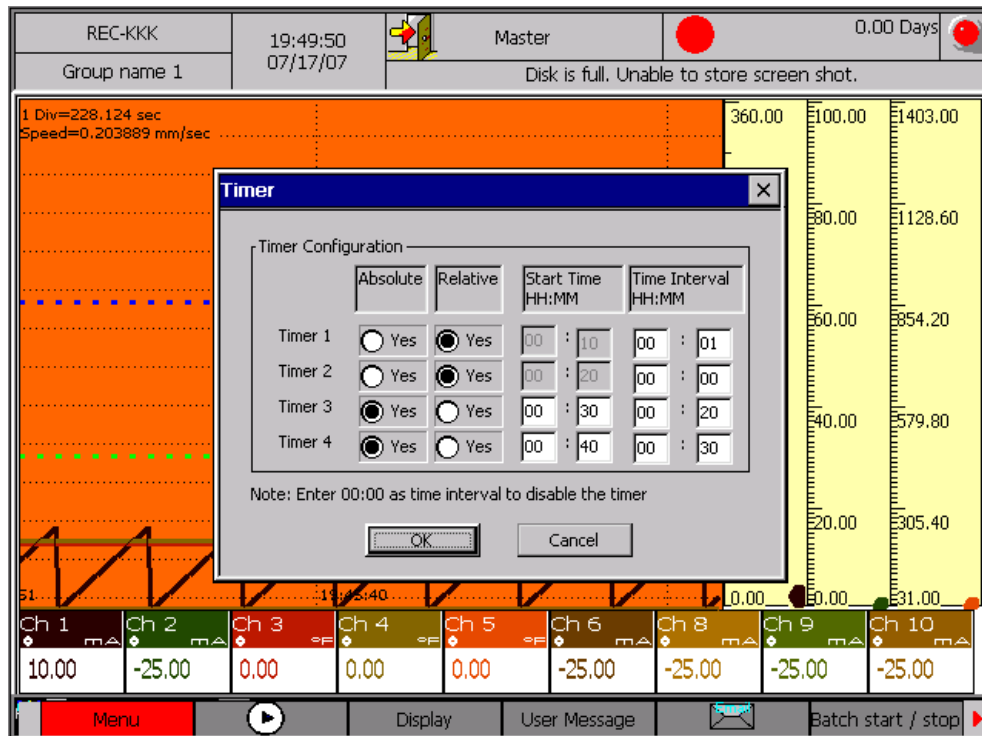

Figure 4. 27: Timer

### 4.1.13 Start-up Image

The starting behavior option of the basic configuration menu will provide two options, default and user defined. If the default option is selected, the initial display will be the default picture. If user defined is selected then, the user can browse for the image file (.bmp) from the USB stick, and the selected file will be updated to the recorder, and the image will be displayed at the starting of the recorder. Recorder can have a maximum of only five startup image files.

Procedure:

1. Select the Menu→ Basic Configuration→ Start-Up Image option.
2. Rotate and press the knob to select either default or User defined option.
3. For user defined option rotate and press to select either browse form recorder or browse from USB option. Browse from recorder will allow the user to select the file from recorder, which stored before. Browse from USB will allow the user to select the .bmp file from USB and the selected file will be copied to recorder.
4. Again rotate the knob and select the OK button. Press the knob to change the Start-up menu.

### 4.1.14 User Keys

After selecting user keys option from Basic configuration menu, the screen will be displayed as follows.

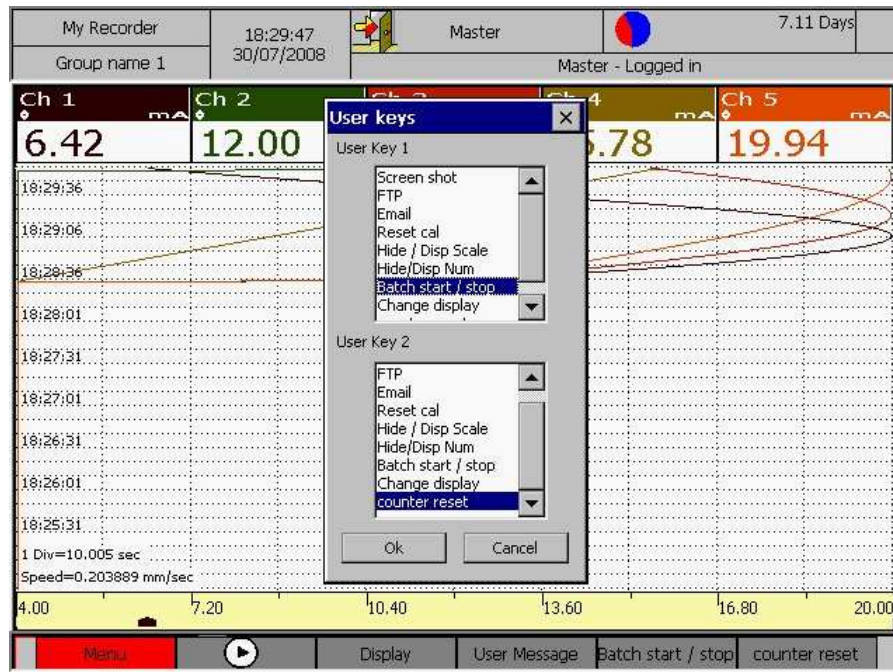



Figure 4. 28: User Key Dialog

Here the user has to select two different actions for user keys. Once after selecting the desired options for user keys 1 and 2, it will be updated in the shortcut bar as follows.

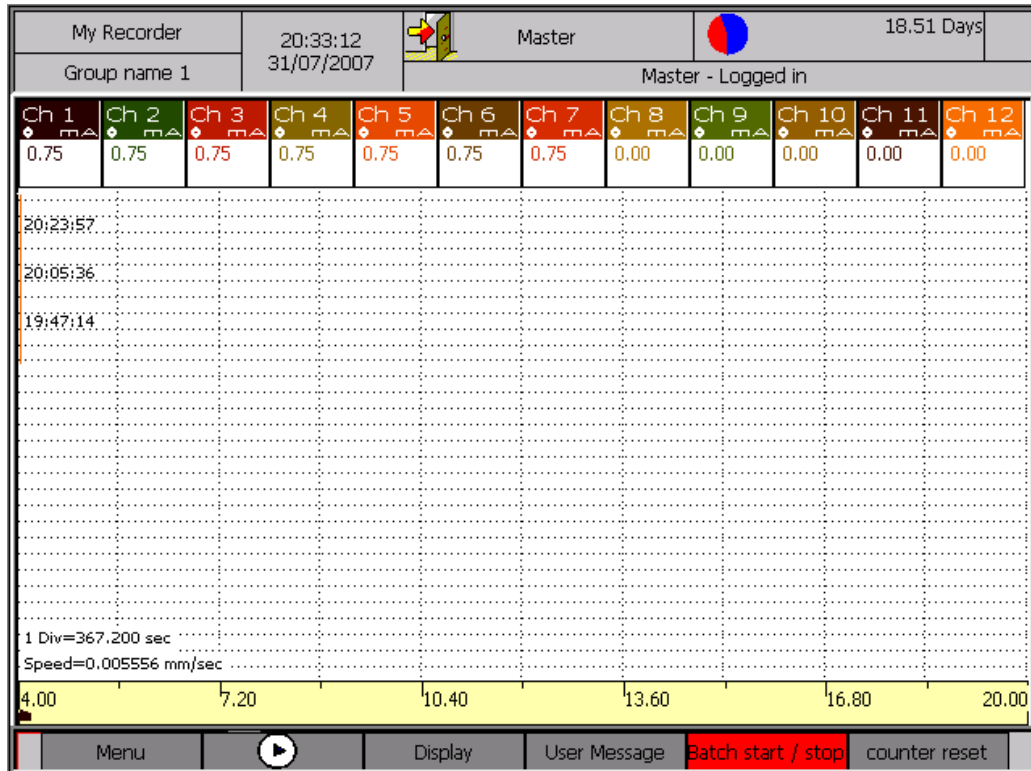

Figure 4. 29: Updated User Keys

Procedure :

1. Select the Menu→ Basic Configuration→ User Keys option.
2. Rotate the knob to highlight the desired user key 1. Press the knob to select the User Key 1
3. Follow the same procedure to select the User Key2.
4. Rotate the knob to select the OK button and press it to set the User keys.

## 4.2 Channel configuration

*Channel Configuration* allows defining behavior of each individual channel of the Recorder. User can use *Channel Configuration* to define the behavior of each individual channel of the Recorder. The recorder supports a maximum of 12 *On-Board* Analog Input channels, a maximum of 12 *External* channels, a maximum of 12 *Calculation* channels and a maximum of 8 On-Board Digital Input channels. However, the actual number of each type of channels available depends upon your selected Recorder Version. A single *Channel Configuration* dialog is used to configure all different types of channels i.e. *On-Board*, *External* and *Calculation* channels.

Procedure: Ensure that recording is OFF. Select the Menu→ Channel Configuration (*Figure 4.31*)  
The *Channel Configuration* Dialog Appears as shown in *Figure 4.32*.

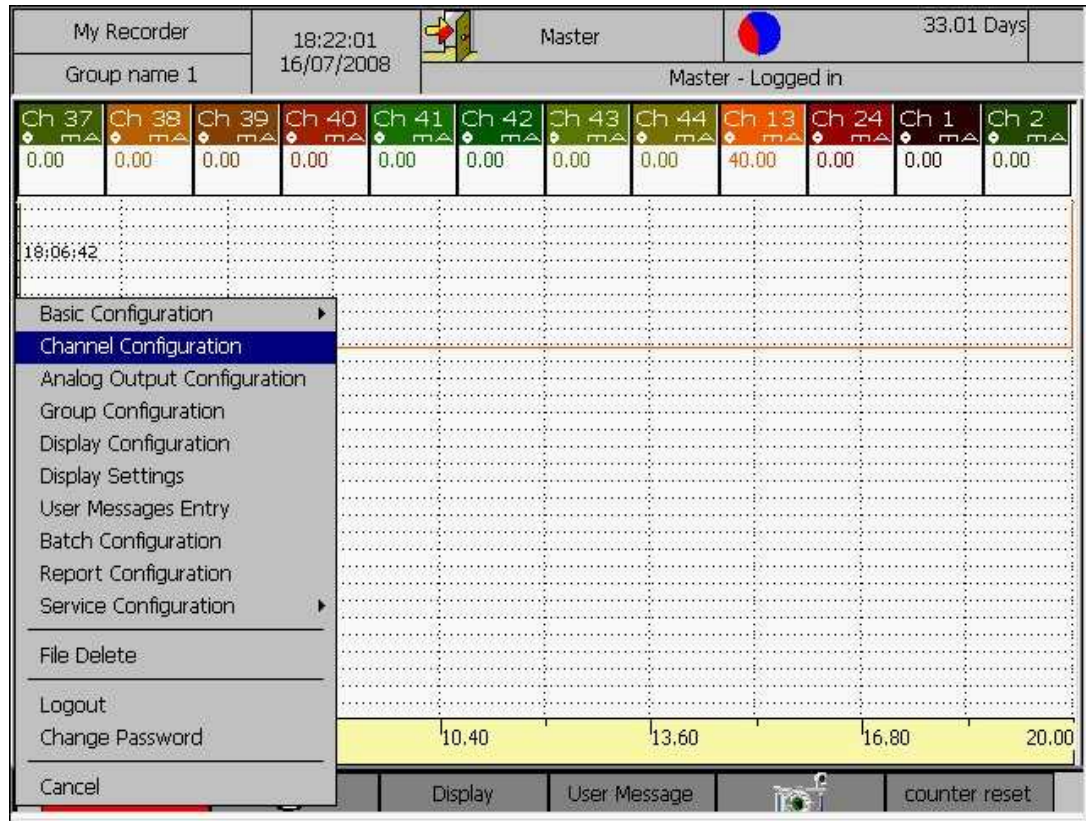

Figure 4. 30: channel Configuration

As soon as the channel configuration dialog comes up, the focus is on the *Channel* Combo-Box, used for selecting the Channel to be configured. Pressing the Knob, when this combo-box is in focus shall cause it to drop down and show a list of all the channels available in the system. This list is enumerated with all the available *On-Board Analog Input Channels*, followed by *Calculation Channels*, *External Channels* and then the *On-Board Digital Input Channels*. By rotating the Knob, focus scrolls through different channels. Pressing the Knob selects the channel under focus. Once a channel is selected, the list closes back. To again change the selection, press the knob, else rotate the knob to move to the next field in the dialog box. Only those fields of the dialog, that are relevant to your selected channel type shall be visible/enabled.

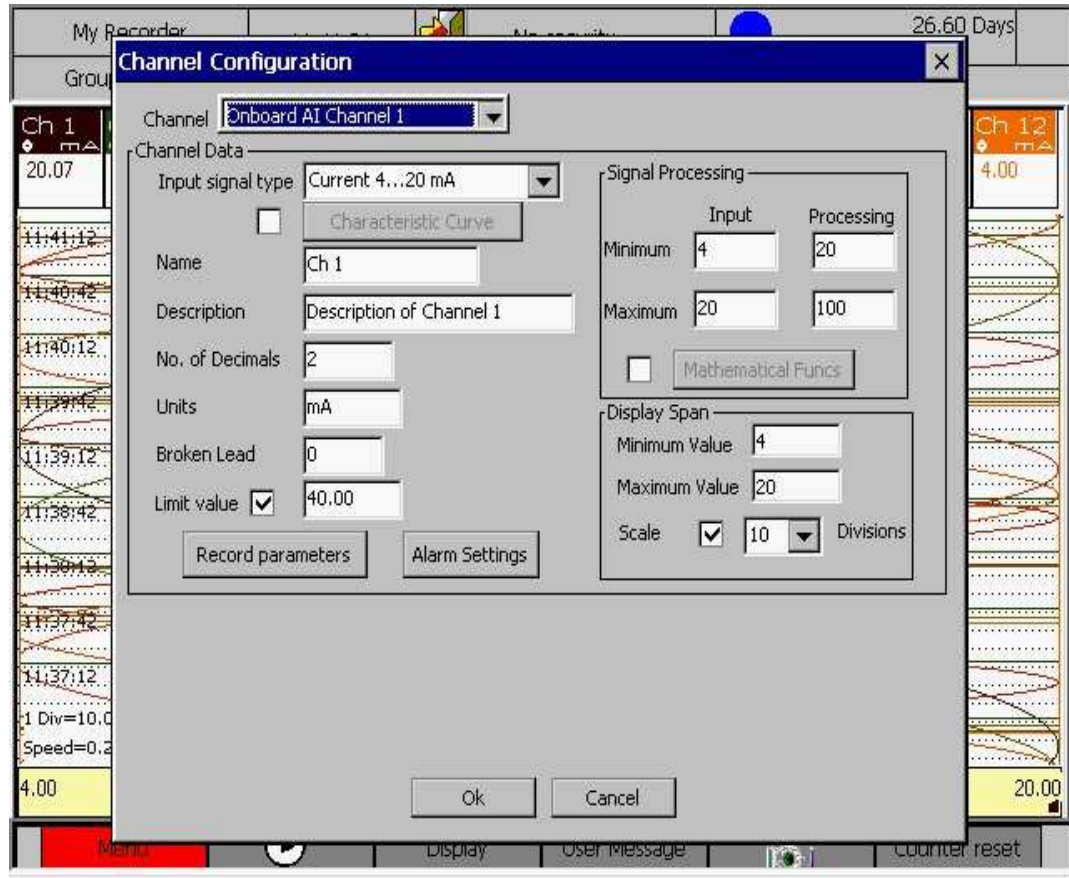

Figure 4. 31: On-board Digital Channel Configuration

#### *On-Board Channels (Analog Input and Digital Input channels):*

All the channels that are directly available with the recorder are the *On-Board* Channels. All the *On-board* channels support universal inputs, so each channel can be configured for any of the Recorder supported input type. The Recorder scans all the *On-Board* Channels with a high precision, collecting five samples every one second and provides *Mean*, *Maximum*, *Minimum*, *Peak Variation* and *Present* values over a user specified recording interval. More details follow in the subsequent text. Here is a listing of all the configurable parameters for *On-Board* channels, along with a description of their effect on the channel functionality:

#### *On-Board Digital Channel:*

A digital channel is made out of a physical channel of 0 through 36 Volts of DC Linear Range. Any voltage level at or above 10 Volts is taken as a *Digital High*, Voltage is less than 10 Volts and above 5 Volts is taken as a either Digital High or Digital Low and a voltage value below 5 Volts is taken as a *Digital Low*.

*Input Signal Type (Digital Channel):*

A digital channel may be used in three different ways. It may be configured as: ‘Counter Input Type’-Recorder reads the channel value every 200 ms, and every LOW to HIGH transition causes the channel value to increment, starting from 0. ‘Operating Hours Counter’-Recorder reads the channel value at the end of each second and if it’s a HIGH, the count is incremented. So, whenever the input is high, the count is incremented every 1 second.’I:I’- The digital wave is displayed/recorded as it is. For a logical LOW, a value of zero is recorded (when the input voltage is less than 5 Volts) and for a logical HIGH, a value of one is recorded. Rotate the knob to move to this field. Select the required *Input Signal Type* (this field is a combo-box and its knob operation is similar to that of *Channel* field). Rotate the knob to move to the next field.

*Name (Digital Channel):*

This field is for name of channel. Rotate the knob, when focus comes to edit box adjacent to channel name, press it. A keyboard will appear. Rotate knob and when it comes to backspace arrow then press the knob until previous channel name is completely cleared. **Now** enter channel name, which will be maximum 16 characters. After entering channel name press Enter on keyboard to confirm the entry.

*Description (Digital Channel):*

A maximum of 64 characters may be used to define a minimal description of each channel.

*Number of Decimals (Digital Channel):*

The channel data is displayed with as many number of decimals places, as specified in this field. This value may be different for different channels within the same group. The field value can be any integer from 0 through 4. Once the *Number of Decimals* is in focus, press the knob to load the virtual keyboard. Using the keyboard, enter the desired field value and press *ENTER* or *ESC* on the keyboard to return to the *Number of Decimals* field. Rotate the knob to move to the next field.

*Unit (Digital Channel):*

The *Unit* field is used to specify the units of measurement of a channel. The channel data is always reported along with the units specified in this field. Maximum allowed length of this field is 10 characters. (The knob operation of this field is similar to *Number of Decimals* field). Rotate the knob to move to the next field.

*Broken lead:*

Broken lead value is assumed by an On-board channel, if sensor-break is detected, or if there is a communication failure with the Input card representing that channel. The value supplied in this

field is used as broken lead value for that particular onboard channel. Note: There is no broken lead value for External and Calculation channels.

*Limit value:*

Limit value is a value, will used to restrict the channel value to cross this value. The Limit value feature will be enabled or disabled through limit value check box. If the actual Channel processed value is greater than limit value, then limit value is used for displaying and recording (Historic, Batch and Report files). This field is available for all the four types of channel (AI, CC, EC and DI).

The value range of this field is in between -100000 to 100000.

For example:

Suppose limit value field is enabled for channel 1 with value 100 and actual processed value for Ch1 is 55, then 55 will be used for displaying as well as recording. If actual processed value for Ch1 is 101 then 100 will be used for displaying as well as recording.

The above example is applicable for all the channels.

**Note:** In DI channel configuration, “Limit value” field will be disabled for signal type “1:1”.

*Recording Parameters (Digital Channel):*

A channel data can be recorded in many different ways. Refer figure 4.33 for the description that follows:

*Standard recording speed:*

Standard recording speed is the speed/rate at which data of a channel is recorded under normal conditions. Recording speed is specified in seconds. For e.g., if a recording speed of 5 seconds is specified for a channel, then data of such a channel is recorded every 5 seconds. However, Display speed is always 1 second for every channel/group and is independent of the recording speed. The fastest recording speed available is 1 second. The default *Standard recording speed* is 60 seconds. When the *Recording Parameters* dialog is opened, the default focus is on the *Standard recording Speed* field. The knob operation for entering the value is similar to that of other fields with text/numeric entries. Maximum allowed value for recording speed is 3600 seconds.

**Note:** Digital channel standard recording speed is fixed to 1(it's not allowing other than 1 sec).

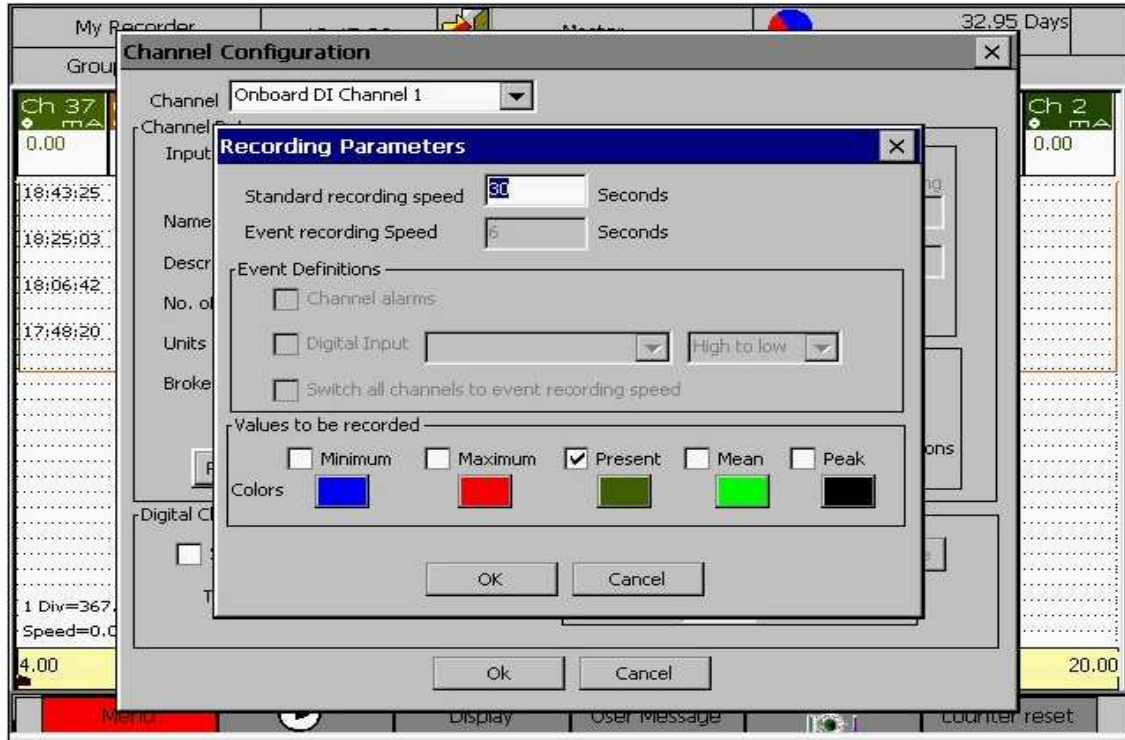

Figure 4. 32: Recorder Parameter Setting

The channel data is recorded with *Event recording speed* whenever the channel is under an event condition. Details of event definition are provided at a later point in this text. The knob operation for this field is similar to *Standard recording speed* field.

#### *Event recording speed:*

The channel data is recorded with *Event recording speed* whenever the channel is under an event condition. Details of event definition are defined at a later point in this text. The knob operation for this field is similar to *Standard recording speed* field.

#### *Event Definitions:*

Two things may define a channel's event-channel's alarm state and/or state (a *HIGH* or *LOW*) of another digital channel. In the former case, whenever a channel enters into alarm condition as per the alarms defined in *Alarm Settings* of that channel, it is treated as an event for that channel, and data recording rate is switched to *Event recording speed*. In the later case, another *Digital Channel* along with a state (*HIGH* or *LOW*) is specified to define a channels event. For E.g. for *On-Board Analog Channel 5*, a *HIGH* state of *On-Board Digital Channel 1* may be defined as an event. In such a case, whenever *On-Board Digital Channel 1* is *HIGH*, *On-Board Analog Channel 5* shall be recorded with *Event recording speed*. Both the conditions may simultaneously be used to define event of a channel. For e.g. *On-Board Channel 5* must be recorded with *Event recording speed* if it is under alarm condition or *On-Board Digital Channel 5* is *HIGH*. Additionally, all the other channels of the Recorder can be switched to *Event recording speed* if event for one channel occurs.

In *Event Definitions* field, the focus first comes to *Channel alarms* check box. Select this option, to provide an event corresponding to alarm condition of this channel. Press the knob to toggle the state of the check box, otherwise rotate the knob to move to the next field. *Digital Input* field is used to nominate another digital channel and its state as an event for this channel. If *Digital Input* check box is selected, then the next two combo-boxes in the same row get enabled and specify the channel and its state respectively. Their knob operation is similar to other combo-boxes of the Recorder. If *Switch all channels to event recording speed* check box is selected, then all other channels switch to their respective event recording speeds, when event for this channel occurs.

*Values to be recorded:*

There are five different values that can be recorded for a channel-*Minimum, Maximum, Present, Mean* and *Peak* value. One or more of these can be selected for recording and display simultaneously.

*Minimum Value:*

It is the minimum value assumed by the channel in the current recording interval. For e.g. if recording speed is 5 seconds, then it is the minimum value from the 40 samples collected for *On-Board* channels during the last five seconds. Press the knob to toggle the state of the check box and enable/disable recording of minimum value. Again turn the knob to move to the next check box.

*Maximum Value:*

It is the maximum value assumed by the channel in the current recording interval. For e.g. if recording speed is 5 seconds, then it is the maximum value from the 40 samples collected for *On-Board* channels during the last five seconds. Press the knob to toggle the state of the check box and enable/disable recording of maximum value. Again turn the knob to move to the next check box.

*Present Value:*

It is the value assumed by the channel in the last sample/scan of current recording interval. For e.g. if recording speed is 5 seconds, then it is the value of 40th sample (last sample) collected for *On-Board* channels during the last five seconds. Press the knob to toggle the state of the check box and enable/disable recording of present value. Again turn the knob to move to the next check box.

*Mean Value:*

It is the mean value assumed by the channel in the current recording interval. For e.g. if recording speed is 5 seconds, then it is the mean value of the 40 samples collected for *On-Board* channels during the last five seconds. Press the knob to toggle the state of the check box and enable/disable recording of mean value. Again turn the knob to move to the next check box.

Note: mean for this period is calculated as:

(Sum of all sample values during recording interval) / (Total number of samples)

*Peak Value:*

It is the difference of *Maximum Value* and *Mean Value* of the current recording interval. Press the knob to toggle the state of the check box and enable/disable recording of peak value. Again turn the knob to move to the button for color selection of *Minimum Value*.

*Color Selection:*

Below each of the *Values to be recorded* is a color selection button. This color is used to represent that particular channel value type in *Live* as well as *Historic Display*. Rotate the knob to reach to the button corresponding to the value type, for which color needs to be changed. Press the knob to bring up color selection dialog. Again rotate the knob to reach to the color of your choice and press it. Press OK to confirm the new color. The color selection button should take up the newly selected color. Refer figure 4.34 below.

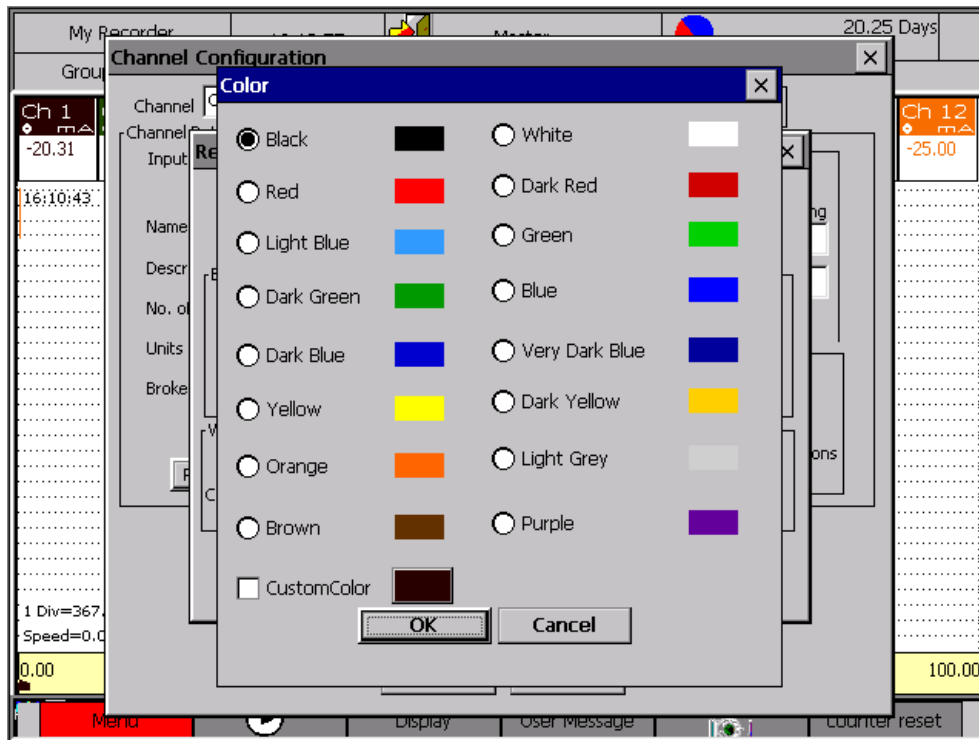

Figure 4. 33: Channel color selection dialog

*Custom colors:*



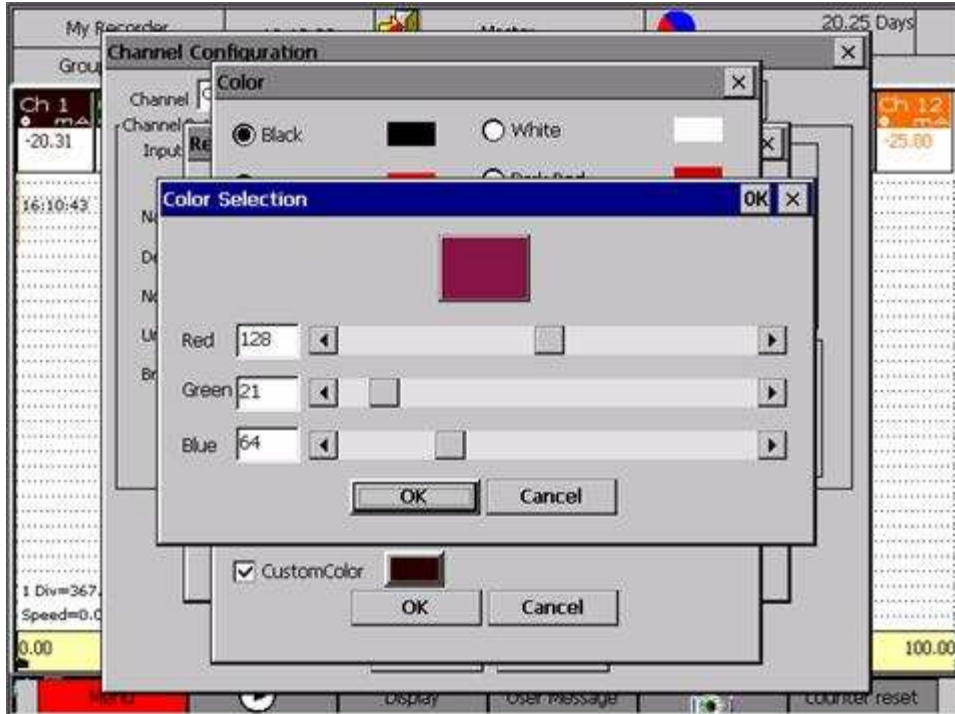

Figure 4. 34: Custom color definition

You can have a custom color for your channel. To define custom color for a channel, in the Color Dialog shown above in fig 4.34, check the 'CustomColor' option, and turn the knob to bring the focus to the color box shown adjacent to 'CustomColor' check box. Press the knob to open a new dialog for making your custom color. Here you can define Red, Green and Blue components and define your custom color. You may directly enter values in edit boxes and see the resulting color in the top square box in this dialog. Additionally, you may select the scroll bar adjacent to each of the components, press the knob and then turn the knob in right or left directions to increase or decrease (respectively) the value of that component. Once your scroll bar position is final, press the knob and turn the knob once to move to the next scroll bar and so on. Confirm your custom color by pressing OK. Refer Fig 4.35 below.

Press *OK* to confirm your *Recording Parameters*. Press *Cancel* to return without saving.

**NOTE:**

1. Only those value types of a channel can be selected for being displayed, those are selected for recording.
2. *Minimum, Maximum, Mean and Peak* values are same as *Present* values for Digital Channels.
3. *External Channels* and *Calculation Channels* have one data sample per second.

*Alarm Settings (Digital Channels):*

On pressing the *Alarm Settings* button, another sub-dialog box appears, and allows configuring up to four different alarms for the channel selected in the parent Dialog Box of *Channel Configuration*. The four alarms of a channel are available only when at-least one from the two options- *Adding To Alarm List* and *Relays* is selected. Refer figure 4.36 for a description of configuring channel alarms that follows:

*Adding To Alarm List:*

Selecting this check box enables automatic logging of all the configured alarms of a channel into the alarm list, whenever they occur. The *Alarm Settings* dialog box opens with default focus on this field. Press the knob to toggle the state of this check box and enable/disable addition to alarm list. Rotate the knob to move to the next field.

*Relays:*

Selecting this check box allows/enables selection of one of the relays to be triggered when channel alarm occurs. Each of the four alarms can then be individually enabled, by selecting the corresponding checkbox. Press the knob to toggle the state of this field's check box. Rotate the knob to move to the first channel alarm. This alarm can be enabled/ disabled by toggling the state of the corresponding check box. The entire row has a set of fields to define the first alarm of this channel. These fields are enabled for an alarm, only if that alarm is enabled. A described of these fields follows and is same for second, third and fourth alarm.

There are three types of Alarms: '*High Alarm*'- Alarm Gets triggered only when the channel value crosses above the alarm value specified in the *value* field. '*Low Alarm*' -gets triggered when the channel value drops below the alarm value specified in the *value* field. '*Gradient Alarm*'-gets triggered when the rate of change of a channel's value increases above the specified limit. Refer Period, Span and Delay description below for details on defining gradients. Digital channels do not support *Gradient Alarms*.

*Value:*

This is the alarm value used to detect a High or Low Alarm. In case of a gradient alarm, this field is not used. The value range is in between -9999999 to 9999999.

**Note:** Digital input channel with signal type is 1:1 then value range is in between 0 to 1.

*Period:*

For *High Alarm* or a *Low Alarm*, this field specifies the alarm hysteresis value. In case of a *High Alarm*, if the channel value goes above alarm value, corresponding alarm initiated. However, alarm ends only when value drops below *Alarm value* minus *Hysteresis* value. In case of *Low Alarm*, if the channel value goes below alarm value, alarm is initiated. However, in this case also, alarm ends only when channel value rises above *Alarm value* plus the *Hysteresis* value. In case of *Gradient Alarm*, this field specifies the time period in seconds over which the gradient has to be calculated. Read through the *Span* field for more information.

**Note:** Minimum period is 0 and Maximum is 32767.

*Span:*

This field is not valid for High and Low alarms. In case of *Gradient Alarm*, an alarm state is achieved if channel value changes more than the *Span* value over a fixed interval of time (specified in the *Period* field). For e.g. if *Period* is specified to be 5 seconds and *Span* is specified to be 200 units then *Gradient Alarm* shall be triggered if the channel value has changed by more than 200 units in last five seconds at any instant of time.

*Delay:*

This field specifies a delay filter for the alarm initiating process, and has a common behavior for all three types of alarms. Once an alarm is detected, it must be present for the amount of time specified in this field (in seconds), before it is actually taken up as an alarm state. However, *Delay* is used only in deciding the start of an alarm, and not while coming out of an alarm.

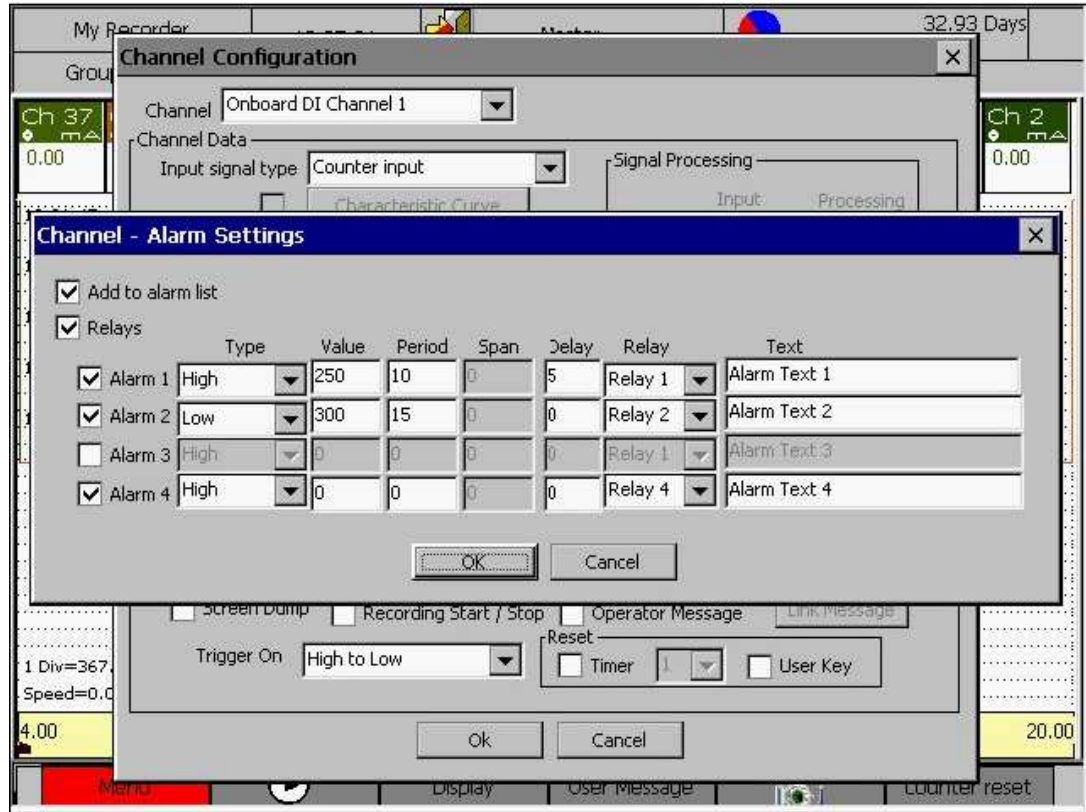

Figure 4. 35: Alarm Settings

*Relay:*

This field is used to associate a relay with the respective alarm. On selecting this combo-box, and pressing the knob, a list of 12 relays is shown. However, it must be ensured that one of the actually available relay is selected. If a relay is selected that is not available, pressing OK shall display an error message asking to review the relay field.

*Alarm text:*

The text specified in this field is logged along the alarm logs, to indicate any information related to the alarm.

The other three channel alarms may be configured in a similar way. Pressing *OK* confirms the new *Channel Alarm Settings* and pressing *Cancel* causes to exit the *Channel Alarm Settings* dialog without saving the changes.

*Display Span:*

This parameter is merely for channels on Display. The trends are plotted within the specified *Minimum Value* and *Maximum Value*. If the channel value lies outside of this range, the channel value can be observed in the digital display in the same group. The knob operation of *Minimum Value* and *Maximum Value* fields is similar to that of *Offset* field (by use of virtual keyboard).

*Scale:*

A scale as per the limits specified in the *Display Span* field may be enabled for being shown in the vertical and horizontal trends for each individual channel. Press the knob to toggle the state of check box and enable/disable scale corresponding to the channel being configured. Rotate the knob to move to the next field.

*Divisions:*

This field is enabled if the scale is enabled. This field specifies the number of divisions to be shown up on the scale. Press the knob to drop down a list of options for number of divisions for a scale. Rotate to move across the different options in the list. Press the knob to select the desired value and rotate again to move to the next field.

*Setting Digital Channels as control for other tasks:*

A digital channel can be set as a control for three operations: 1) Taking a screen shot of the display when a digital channel changes its state in a particular direction, 2) starting or stopping recording (toggling the current recording status from start to stop and vice versa) when a digital channel changes its state in a particular direction and 3) generating an operator message when a digital channel changes its state in a particular direction. A digital channel may be configured as control for one, two or all of these operations, simply by enabling the corresponding check boxes.

*Screen Dump:*

Press the knob to toggle the state of the check box and enable/disable a screen dump action with a change in the state of this digital channel. Rotate the knob to move to the next field.

Note: If a digital channel is switching from high to low and low to high with a minute then the screen shot will be taken after minute i.e. the time gap between two successive screen shots from a digital channel will be a minute.

*Recording Start/Stop:*

Press the knob to toggle the state of the check box and enable/disable starting of recording (when its already stopped) and stopping of recording (when its already started) with a change in the state of this digital channel. Rotate the knob to move to the next field.

*Operator Message:*

Operator messages are small text messages that can be dumped into a specified group file as well as displayed on the task bar. Press the knob to toggle the state of the *Operator Message* check box and enable/disable generation of an operator message with a change in the state of this digital channel. Use the *Trigger On* field (explained below) to specify HIGH to LOW or LOW to HIGH transition of this channel as triggering event for operator message. Rotate the knob to move to the next field. Refer Link Message field description for choosing the operator message and the group to which it should be associated.

*Link Message:*

This field is enabled if operator message generation is enabled in the field above. Press the knob on the *Link Message* button to bring up the *User Messages* dialog as shown below in Fig 4.37. Here you have a choice to pick up a message from the predefined user message template list (editable at Menu→User Messages Entry) or frame a new message. Press OK to set your choice. Rotate the knob to move to the next field.

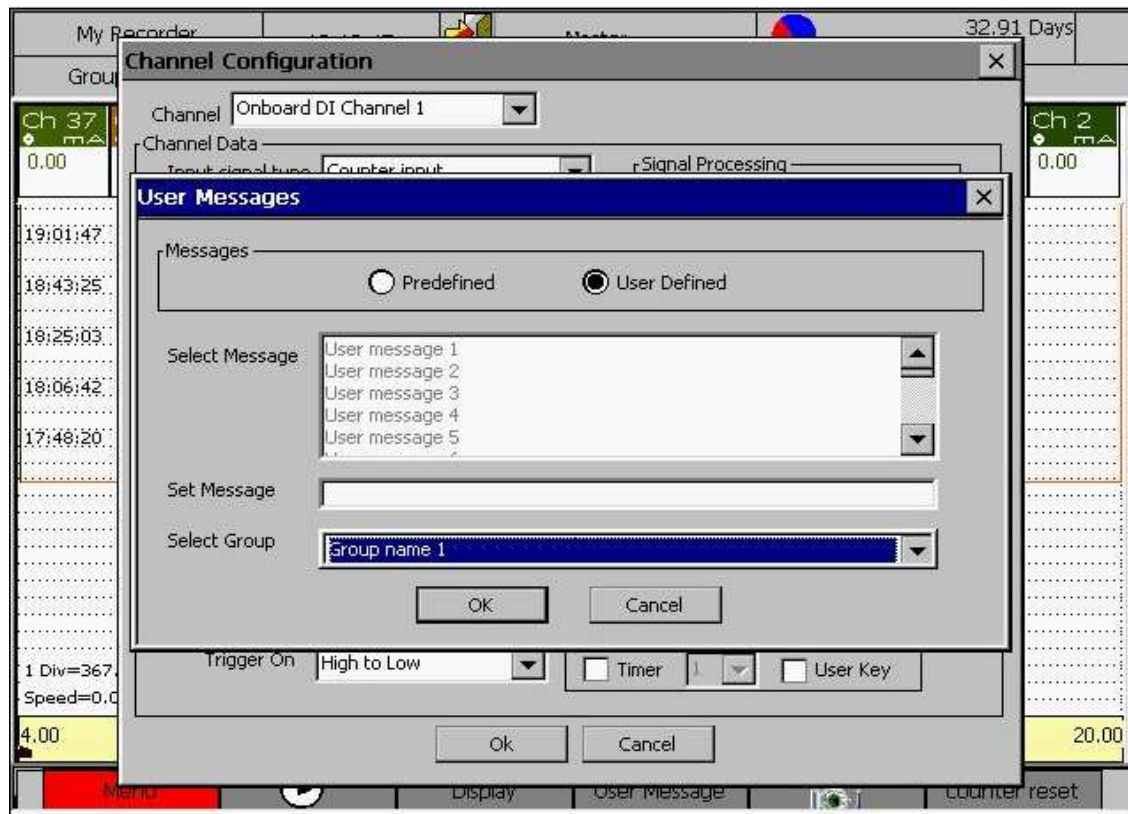

Figure 4. 36: Linking User Message to a Digital channel

*Trigger On:*

Additionally, the above-mentioned three actions may be associated with this digital channel's *LOW* to *HIGH* transition or a *HIGH* to *LOW* transition. Press the knob to show a list of these two options. Rotate to select the required option and press to confirm. Again rotate the knob to move to the next field.

*Reset:*

A digital channel when configured as operating hours counter type or counter type may be required to reset at fixed intervals. In such a case, one of the four Recorder timers may be associated with this digital channel. Whenever the selected timer triggers, the channel value is reset to 0. Alternatively, such a channel may be reset manually using a user key. Both reset options manual also be selected simultaneously for a digital channel. In case more than one digital channels are enabled for being reset using a user key, only one user key is available on the shortcut bar that resets all these digital channels at once.

*Timer:*

Press the knob to toggle the state of this check box to enable/disable reset using a timer. If it is selected, a drop-down combo-box gets enabled, that allows selection of one of the four timers. Rotate the knob to move to the next field.

*User Key:*

Press the knob to toggle the state of this check box to enable/disable reset using a user key. Rotate the knob to move to the OK/Cancel buttons. Press OK to confirm the changes and exit. Press Cancel to exit without saving. To configure another channel, rotate the knob further to move to the first field of *Channel*.

**Note:** Change in the configuration (Ex: channel configuration, group configuration) is reset the Digital input channel count to zero.

*On-Board Analog Channel:*

An *On-Board Analog Channel* is a physical channel that may be used for measuring analog signals such as temperature, voltage, current etc. Some of the parameters available for configuring analog channels are different from those for digital channels and are detailed below (refer figure 4.38 for the details that follow).

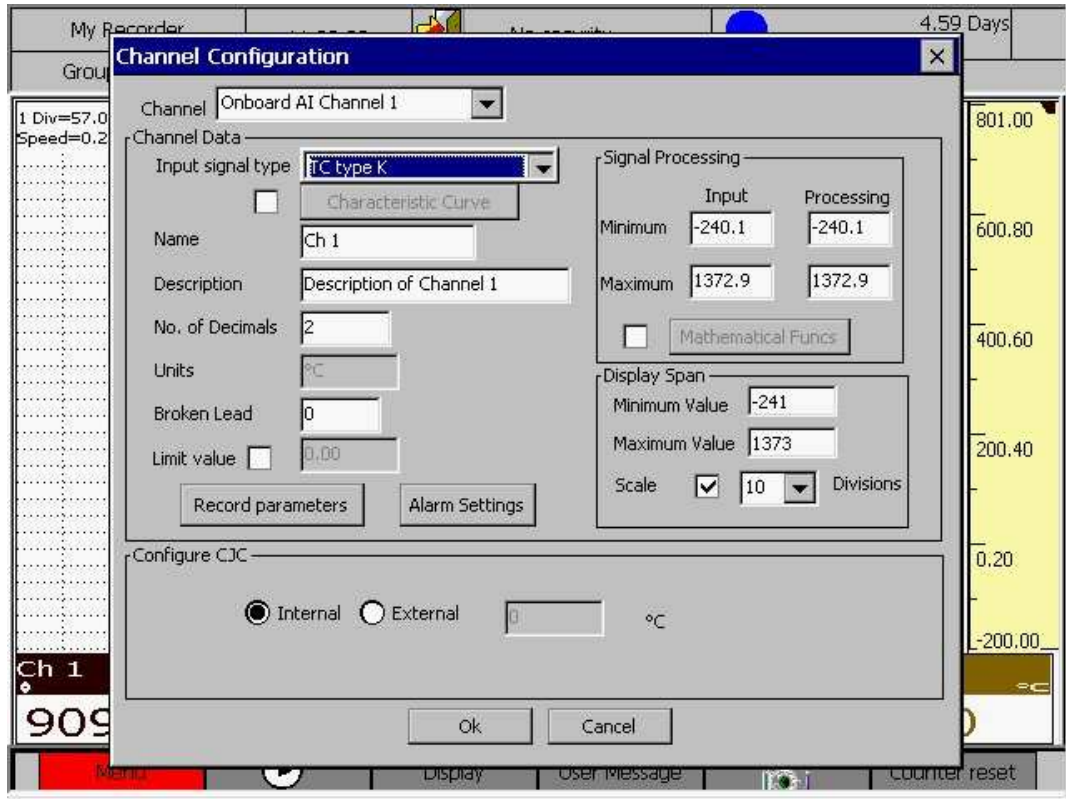

Figure 4. 37: On-Board Analog channel configuration

#### *Input Signal Type (Analog Channels):*

An analog channel may be configured to measure any of the following input signal types:

0. TC TYPE L
1. TC TYPE J
2. TC TYPE K
3. TC TYPE N
4. TC TYPE S
5. TC TYPE R
6. TC TYPE T
7. TC TYPE C (Currently not supported)
8. TC TYPE D (Currently not supported)

9. TC TYPE E
10. TC TYPE B
11. PT-100
12. PT-1000 (Currently not supported)
13. KTY 11-6 (0...4) (Currently not supported)
14. KTY 11-6 (0...5) (Currently not supported)
15. NI 120
16. CURRENT 0 - 20 mA
17. CURRENT 4 - 20 mA
18. DC LINEAR -5 - 5 V (Currently not supported)
19. DC LINEAR -10 - 10 V (Currently not supported)
20. DC LINEAR -200 - 200 mV (Currently not supported)
21. DC LINEAR -500 - 500 mV (Currently not supported)
22. DC LINEAR 0 - 50 mV
23. DC LINEAR 10 - 50 mV
24. DC LINEAR 0 - 5 V
25. DC LINEAR 1 - 5 V
26. DC LINEAR 0 - 10 V
27. DC LINEAR 2 - 10 V
28. POTENTIOMETER 0...160 (Currently not supported)
29. POTENTIOMETER 0...450 (Currently not supported)
30. POTENTIOMETER 0...1600 (Currently not supported)
31. POTENTIOMETER 0...4500 (Currently not supported)
32. EXTERNAL INPUT



Press the knob to drop down a list of configurable input types as enlisted above. Rotate the knob to select the desired input type and press the knob to confirm. Again rotate the knob to move to the next field.

Changing the selection in Input Signal Type field causes the dialog to suggest the default Process Minimum, Process Maximum, Input Minimum, Input Maximum, Display Minimum and Display maximum values for that input type. However, these can be modified as required and confirmed by pressing OK. Pressing cancel causes the previous settings to prevail.

#### *Characteristic Curve (Analog Channels):*

Characteristic curves are provided for the analog channels to allow defining a custom-mapping curve for a given range of analog inputs. Press the knob to toggle the state of the check box and enable/disable characteristic curve mapping for current channel being configured. Rotate the knob to move to the *Characteristic Curve* button (this button is enabled only if the adjoining check box is selected). Press the button to show up a sub dialog box that may be used to define the custom mapping.

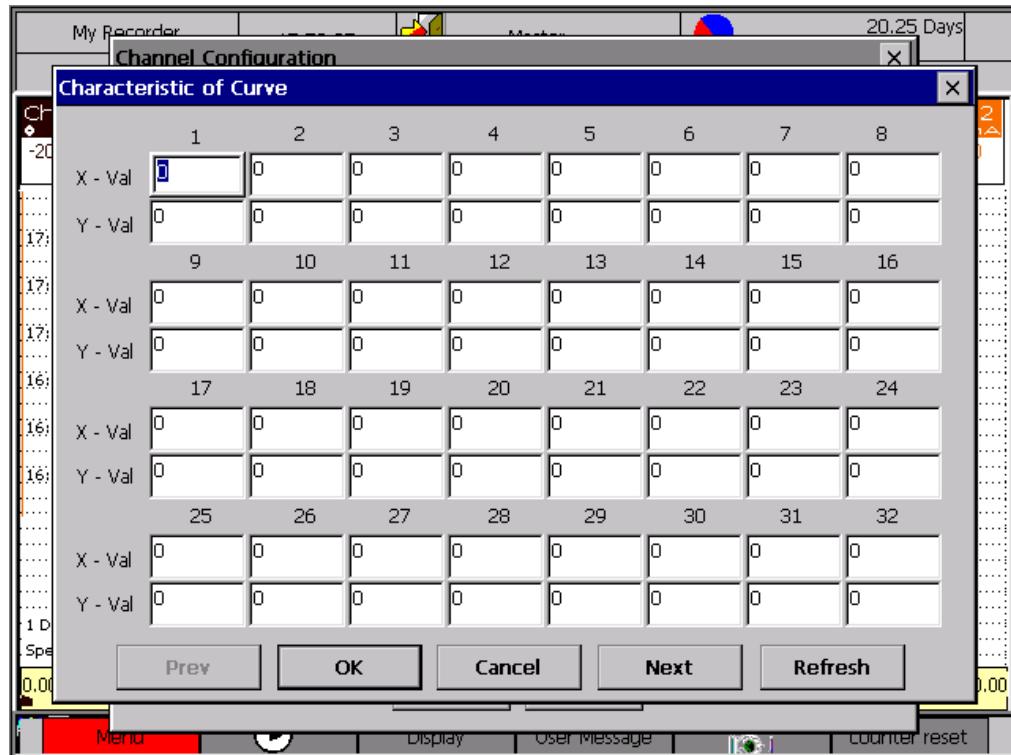

Figure 4. 38: 64 Data Points Entry Screen

Custom mapping can be defined using a maximum of 64 pairs of values (X vs. Y). X-values are the values received from the sensor. Y-values are the corresponding values assumed by the channel. It is not mandatory to input all the 64 pairs of values however. Required number of pairs may be entered in random order. The dialog is divided into two pages of 32 pairs each. Press the *Next* button to move to the second page when currently on first page and use *Previous* button to

move to the first page when currently on second page. After entering the required mapping pairs, press the *Sort* button to sort the entered pairs in descending order. Press *OK* to confirm the mapping and press *Cancel* to exit without saving.

Note: Interval between two adjacent X-value pairs is linearly interpolated. If the value is Outside of the interval covered by the characteristic curve mapping, lower and upper limits as per the mapping curve are assumed by the channel for input values below and above the minimum and maximum X-values respectively in the mapping curve.

*Signal Processing (Analog Channels):*

Analog channels have a set of parameters that allow linearization, scaling and minimal mathematical operations on the channel values. Four parameters namely-*Input Minimum*, *Input Maximum*, *Process Minimum* and *Process Maximum* are used to provide linearization and scaling for the channel data. The *Process Minimum* is the channel value, when the actual input value to the channel is *Input minimum*. Similarly, the *Process Maximum* is the channel value, when the actual input to the channel is *Input Minimum*. Additionally, the entire range of input is linearised according to this equation.

Within the signal processing group, the focus first comes at *Input Minimum*. Press the knob to show up the virtual keyboard. Enter the desired value using the keyboard, press ENTER to confirm and ESC to close the keyboard without updating new value in the field. Rotate the knob to move to the next fields. Process Minimum, Input Maximum and Process Minimum also have a similar knob operation. Turn the knob to move to the next field-*Mathematical Func* that is used to define a minimal mathematical operation on the channel's value obtained after adding offsets and performing all the scaling as per *Input Minimum*, *Input Maximum*, *Process Minimum* and *Process Maximum*. Press the knob to show up a sub dialog box for entering the mathematical expression as shown in figure 4.40 below.

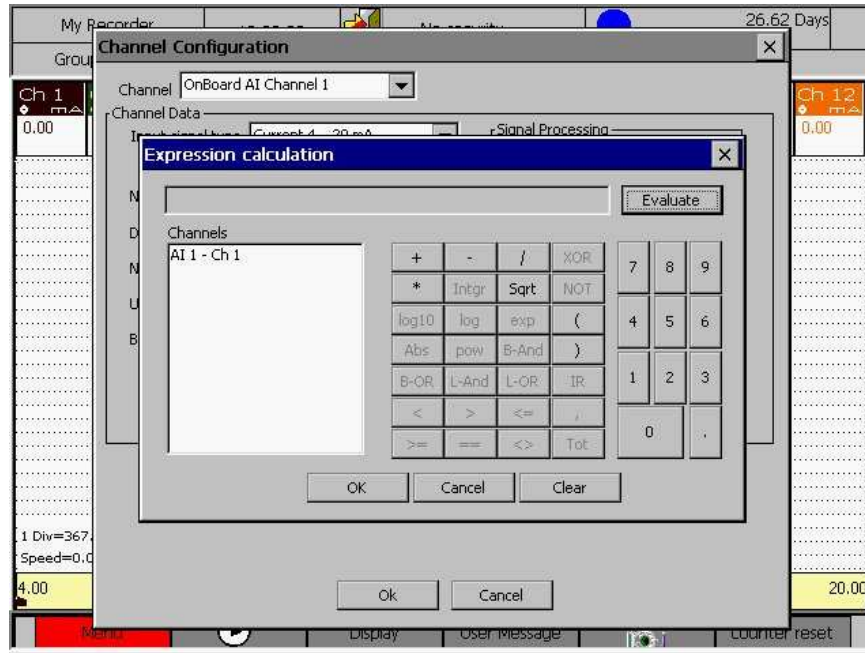

Figure 4. 39: Expression Calculation Dialog for Analog Channels

Operations available on channel values are-Addition, Subtraction, Multiplication, Division and Square root, along with usage of constant values in the expression. After creating the required expression, Press the *Evaluate* button to validate the entered expression. In case the expression is not valid, the channel shall assume zero value. Press *OK* to save the expression and return to Channel Configuration dialog box and *Cancel* to return without saving. Press *Clear* to clear the entered expression.

Note: Mathematical function is applied to the channel data only when the check box adjoining the *Mathematical Funcs* button is enabled.

#### *Configuring CJC (Analog Channels):*

For analog channels of type TC or RTD, configurations need to specify that CJC (Cold Junction Compensation) has to be Internal or External. If CJC is selected as *External*, then a compensation value must be specified, that is added to the value received from the sensor.

Using the recorder knob, select the *Internal* or *External* radio button as required. If *External* is selected, *Units* field gets enabled to add the compensation value.

Apart from the parameters discussed above for Analog Channels, all other parameters available for analog channels are same as they are for digital channels.

#### *Calculation Channels:*

Most of the parameters for calculation channels are same as those for On-board channels. Parameters that are different from those for On-Board channels are described here.

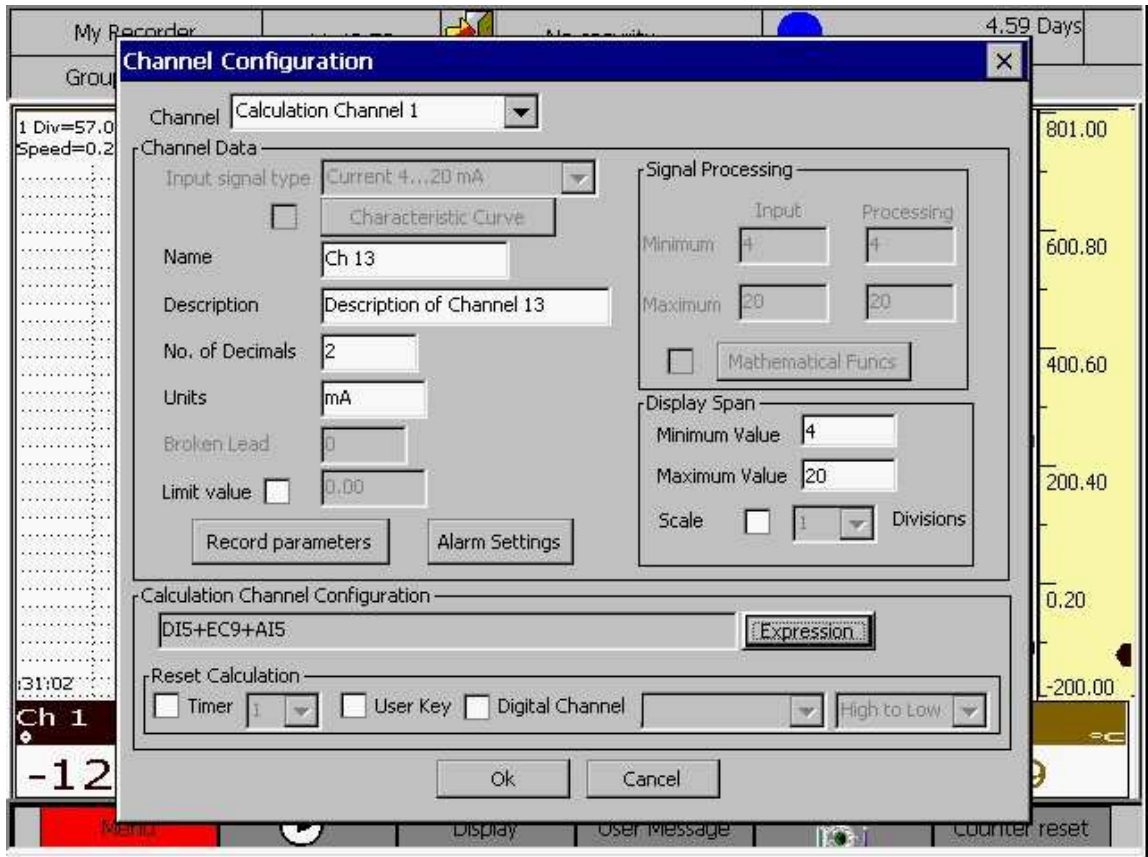

Figure 4. 40: Calculation Channel Configuration

To enter the calculation expression for selected calculation channel, press the Expression button as shown in figure 4.41, to show up a sub dialog box for generating the expression. When the Expression Calculation dialog box shows up (refer figure 4.42), the default focus is on the Evaluate button. Press this button to validate your expression before confirming it. An invalid expression shall cause the corresponding calculation channel to assume a zero value.

For e.g. an expression of the form  $AI1 + * AI2$  is incorrect, and consequently validation shall fail for such an expression.

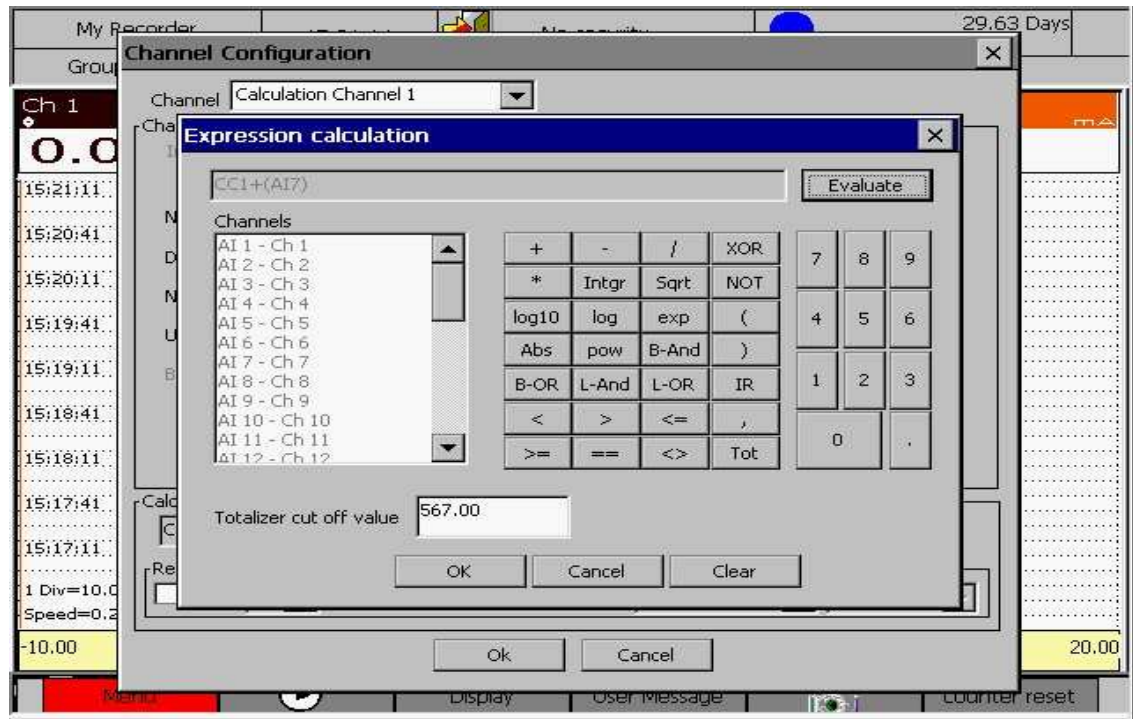

Figure 4. 41: Expression Entry Screen

The dialog resembles a calculator key pad. Mathematical function may be selected from the middle key pad, while channels to be used in calculation expressions may be selected from the list on the left of the functions key pad. Constant values may be entered using the numeric key pad to the right of the functions key pad. Press OK to confirm the entered expression, Cancel to exit from this dialog box without saving the any changes to the expression and press Clear to clear the entered expression and enter again.

The functions available in the functions key pad are as follows:

Operation	Symbol
Addition	+
Subtraction	-
Division	/
Multiplication	*
Integration	Intgr
Square rooting	Sqrt
Logarithm base 10	Log10
Natural logarithm	Log
Exponent	Exp
Absolute value	Abs
Exponentiation (x <sup>y</sup> )	Pow
bit-wise AND	B-AND
bit-wise OR	B-OR
logic AND	L-AND

logic OR	L-OR
smaller	<
greater	>
greater or equal	>=
smaller or equal	<=
Equal	=
not equal	<>
XOR	XOR
NOT	NOT
(	(
)	)
Integer Ratio	IR
Totalizer	Tot

Table 1: Mathematical and Logical Expression

Using Integration function (Intgr):

Integration function works with two parameters where in, the first parameter corresponds to 'X' and second parameter corresponds to 'n' such that following integration is performed:  $\int x^n \cdot dx$ .

E.g.:  $\int EC1^3 \cdot EC1$  should be entered as: (Intgr (EC1, 3))

Using Totalizer function (Tot):

Totalizer is a summation of channel value at a regular interval of time. On pressing "Tot" button in the expression screen it will be cleared in the expression text box (if any thing is there) and new expression starts with "CC1+( " if the user selected calculation channel 1 in channel configuration dialog.

To set the Analog Input 1 (AI1) channel in the Totalizer with Calculation channel 1 (CC1), select calculation channel 1 from the channel configuration dialog and open expression dialog as shown above. Press the "Tot" button, the expression will be "CC1+( " then select AI1 from the channel list, the final expression will be "CC1+(AI1) ". This feature is available only for calculation channels and disabled for rest of the channels (AI, EC).

Totalizer Cut Off value edit box will enable when user presses the "Tot" button. This field is useful to enter cut off value for the selected channels either AI or EC channels. This field will disable when user presses the Clear button. This field will accept values between -100000 to 100000. If value outside this range or empty software will pop up a message "Totalizer cut off value field is empty or enter value between -100000 to 100000".

Channel list box will disable when user selected any channel from the list after pressed "Tot" button. This field will enable when user presses clear button.

The DI channels will not shown in the channel list when user presses the "Tot", because user can use the DI channel as a Totalizer using DI channel "Counter Input" signal type.

Example:

Let AI1 (onboard Analog Input) be measuring the rate of flow in seconds. To compute total flow at a given point of time (from start of recorder or latest reset calculation event), CC1 (calculation channel 1) may be defined as follows:

$CC1 = CC1 + (5 + AI1 + 6)$ ;

AI1 channel Cut Off value is 4

Sec 0:

AI1 = 0; CC1 = 0; present value of AI1 after applied all the processing scaling factors (Input Min, Input Max, Processing Min, Processing Max from the channel configuration).

Sec 1:

AI1 = 20; CC1 = 31;

Sec 2:

AI1 = 3; CC1 = 31;

Sec 3:

AI1 = 8; CC1 = 50;

**Note:**

1. AI1 value would be the present value of AI1 at the end of 1 sec (5 scans) after applying any math processing specified in AI1 settings (AI channel configuration like characteristic curve etc.).
2. "Tot" button will be enabled only for Calculation channel & not for AI & EC channels.
3. User can view Totalized value through display and also through the recorded files.
4. Totalizer cut off value is visible only for calculation Expression channel.
5. DI channels are not available in the channel list after pressing "Tot" button in the expression dialog.

**Note:** There is no forcible reset for Totalizer when user starts the Recording using short cut key or recording start automatically on timing basis set by the timer configurations.

Reset Calculation:

Just as digital channels can be reset using one of the timers or manually using a user key, Calculation Channels can also be reset using a timer, a user key and additionally with another digital channel's change of state in appropriate direction (LOW to HIGH or HIGH to LOW). The knob operation for selecting a timer or a user key is same as that in case of a digital channel. Digital channel field is used to nominate another digital channel and its rising or falling edge to reset calculation of this channel. If Digital channel check box is selected, then the next two combo-boxes in the same row get enabled and specify the channel and its state transition respectively. Their knob operation is similar to other combo-boxes of the Recorder.

External Channels:

Most of the parameters for external channels are same as those for On-Board channels except for the Input type, which is substituted by the MODBUS slave and register address of that channel.

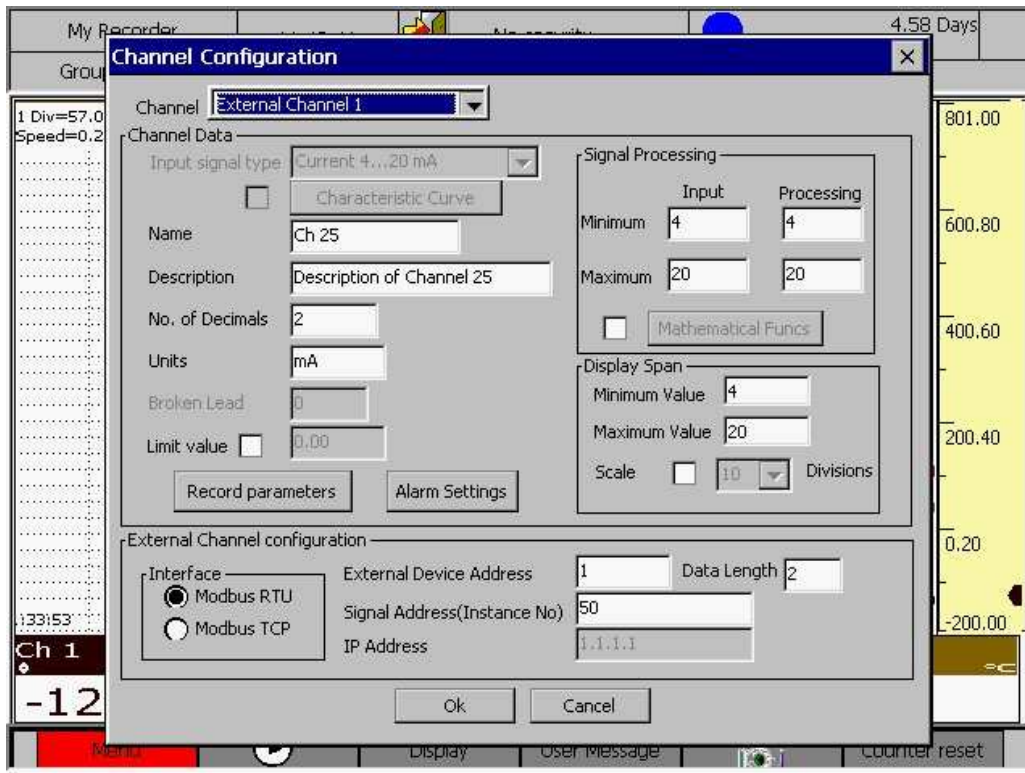

Figure 4. 42: External Input Channel Configuration

Only those parameters that are different from the On-Board channels are discussed here. Refer figure 4.43 for details that follow.

External Channel configuration:

This field is exclusive to external channels, and is used to nominate the MODBUS network related parameters for each of the external channels.

Interface:

An external channel may present in a MODBUS/TCP or MODBUS/RTU network. Press the knob on the appropriate radio button to select the required option. Rotate the knob to move to the next field.

External Device:

This field specifies the MODBUS slave address that can be anything from 1 through 247. Virtual key board is used to enter the required slave address. Once done, rotate the knob to move to the next field.



**Data Length:**

This field specifies the number of words to read starting from the specified Signal Address. Only valid entries for this field are 1 or 2. A single word read implies that only process value is read and no status word is read against that process value. A two word read implies that the first word is a process value and the next word read is a status word corresponding to that process value. Virtual key board is used to provide the field value. Once done, rotate the knob to move to the next field.

**Signal Address:**

This field specifies the slave register address for the process value variable. Virtual keyboard is used to provide the field value. Once done, rotate the knob to move to the next field.

**IP Address:**

This field gets enabled if the interface is selected as MODBUS/TCP and specifies the IP Address of the slave device. Virtual keyboard is used to input the IP address. Once done, rotate the knob to move to the OK/Cancel buttons.

Note: The input parameter value to an External Modbus Master is 3276, for any value above 3276 it's unpredictable.

### 4.3 Analog Output Configuration

*Analog Output Configuration* allows defining behavior of each Analog Output channel of the Recorder. User can use *Analog Output Configuration* to define the behavior of each individual channel of the Recorder. The recorder supports a maximum of 6 Analog Output channels.

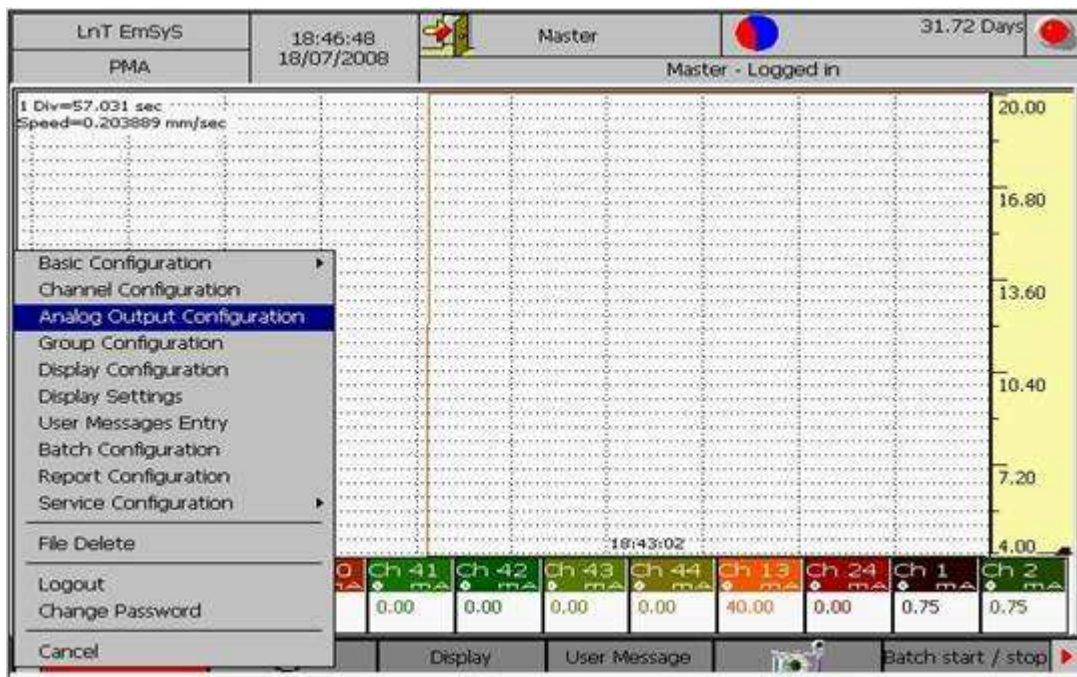

Fig 4.44 Analog Output Configuration

Procedure:

Ensure that recording is OFF. Select the Menu→ Analog Output Configuration (Refer *Figure 4.44 below*)

Analog Output Configuration dialog appears as shown in Fig 4.45, if Analog Output card is available otherwise message is displayed as “Card is not available in recorder”.

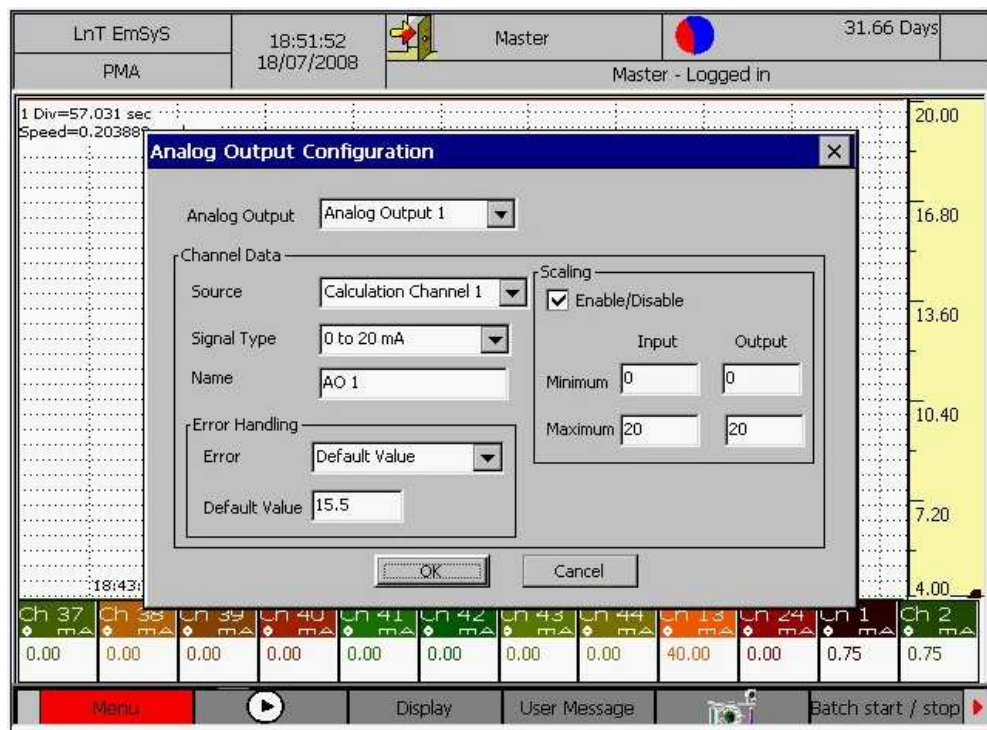

Fig 4.45 Analog Output Configuration

As soon as the AO configuration dialog comes up, the focus is on the Analog Output Combo-Box, used for selecting the AO Channel to be configured. Pressing the Knob, when this combo-box is in focus shall cause it to drop down and show a list of all the AO channels available in the system. This list shows all the available AO *Channels*. By rotating the Knob, focus scrolls through different AO channels. Pressing the Knob selects the channel under focus. Once a channel is selected, the list closes back. To again change the selection, press the knob, else rotate the knob to move to the next field in the dialog box. Only those fields of the dialog, that are relevant to your selected channel type shall be visible/enabled.

**Source:** This option will allow you to select the source channel which is to be retransmitted for the selected Analog output channel. Source channel may be onboard analog input channel (1 to 12), Calculation channel (1 to 12) or External channel (1 to 12).

**Signal Type:** Analog output channel may be configured in two different signal types. It may be 0-20mA or 4-20mA. If you select signal type as 0-20mA the Analog output value will be in between 0 and 20mA. If you select the signal type as 4-20mA the Analog output value will be in between 4 to 20mA.

**Name:** This field allows you to name the Analog Output channel. Rotate the knob, when focus comes to Name edit box press it, a keyboard will appear. Rotate knob till the focus comes to backspace arrow then press the knob until previous channel name is completely cleared. Now enter channel name, which will be maximum 16 characters. After entering channel name press Enter on keyboard to confirm the entry.

**Error:** Analog output channel may be configured for 3 different types of error values. It may be Zero value, Last value, Default value. If you select Error value as Default value you can enter the default value in “Default value” edit box. This value should be within 0 to 20, if the signal type selected is 0-20 mA or in between 4 to 20 if the signal type selected is 4-20mA. If you enter beyond these limits an error message will be displayed.

**Scaling:** Scaling is enabled only if you check the “Enable/Disable” check box. On checking “Enable/Disable” you will be allowed to enter Input minimum, Input Maximum, Output Minimum and Output Maximum otherwise all the text boxes will be disabled. Here you can enter any value in between -100000 to 100000 for Input minimum and Input Maximum and between 0 to 20 for Output Minimum and Output Maximum if the signal type selected is 0-20mA. For Signal Type 4-20mA input limits are same and Output Minimum, Output Maximum values should be within 4 to 20. If you enter the values beyond these limits application will display an error message.

#### **4.4 Group Functions**

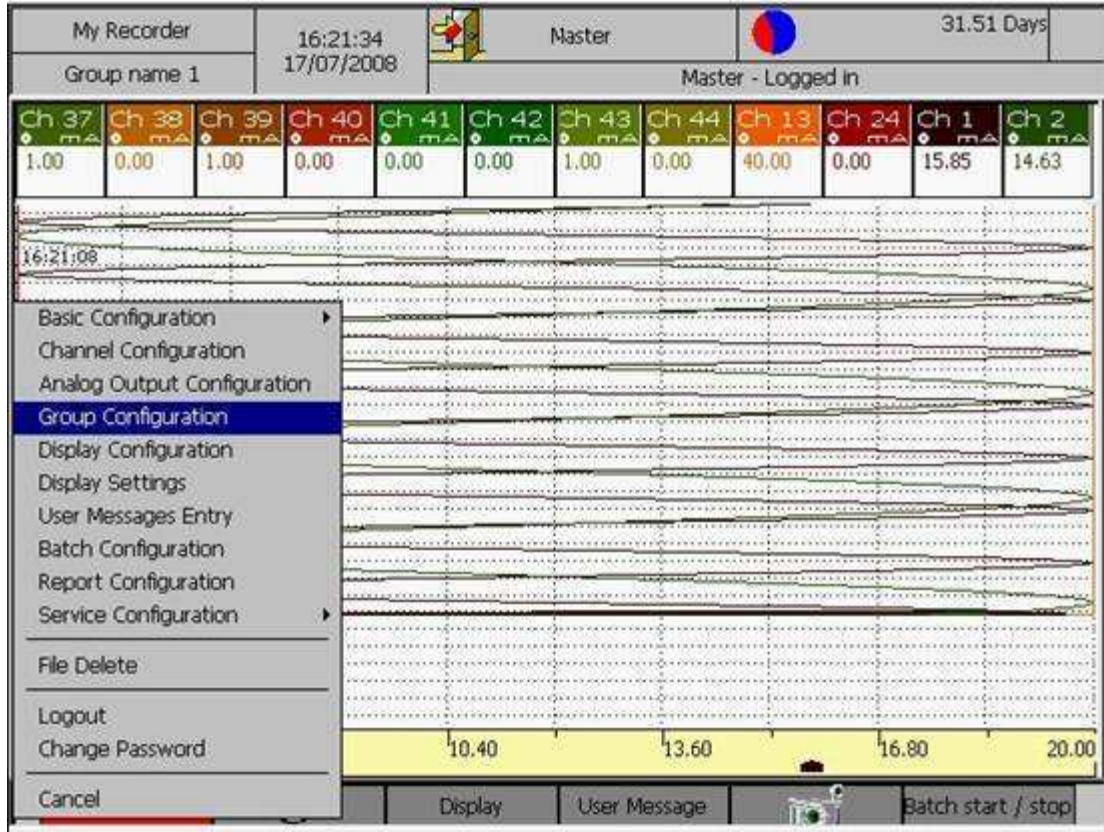

Figure 4. 46 Group configuration

Group is a collection of channels. A Group can have 1 to 12 channels. It should have at-least one channel in it. User can view all the values (minimum, maximum, present, peak and mean) of a channel, they are considered as separate channels for display. All the values of a channel that have been selected for recording purpose will be entered in the files of the groups to which the channel belongs.

Procedure:

Ensure that the recording is OFF. Select the Menu→ Group Configuration (Refer Figure 4.46 below)

The *Group Configuration* Dialog Appears as shown in Figure 4.47below

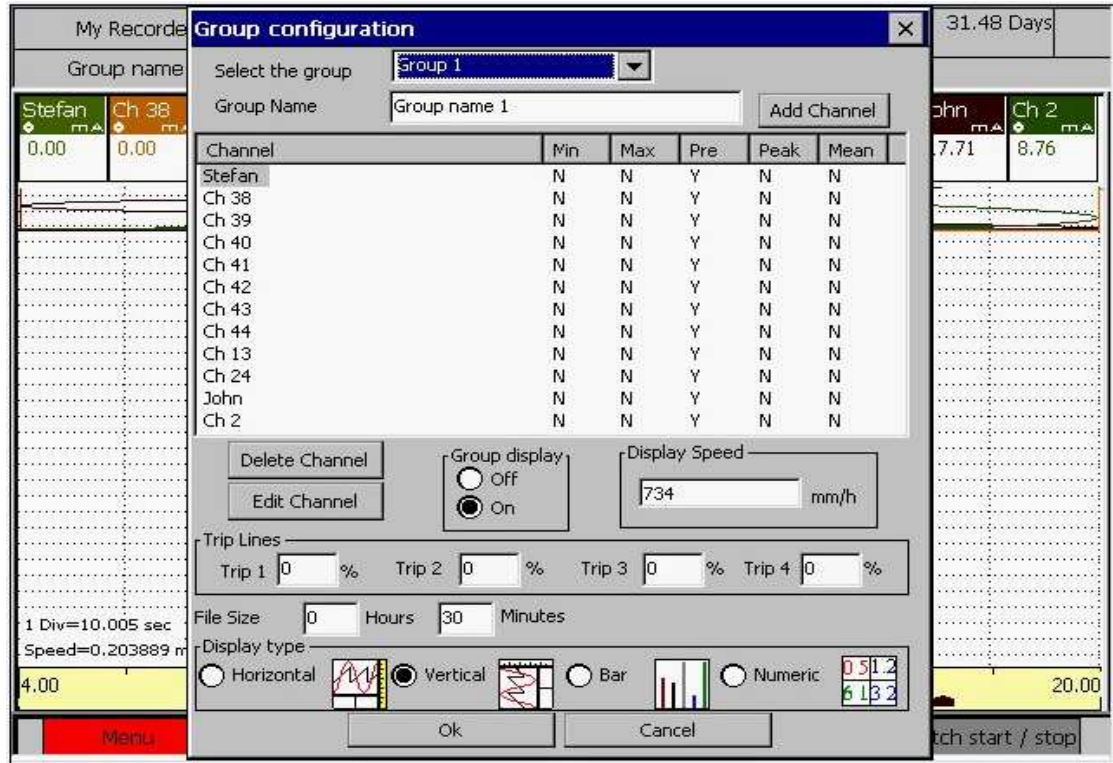

Figure 4. 437: Group Configuration

As soon as the Group configuration dialog comes up, the focus is on the 'Select the group' combo-box, used for selecting the Group to be configured. Press the knob to list all the 8 groups. Rotate the knob to scroll through different groups until the required group is reached. Press the knob to select group in focus. Once a group is selected, the list is closed. To change the selection, press the knob, else rotate the knob to move to the next field in the dialog box.

#### Group Name:

This field allows you to name the Group (maximum 16 characters). This name will be displayed in status bar when corresponding group is being displayed. Once the focus is on 'Group Name', press the knob to load virtual keyboard. Enter the name of group and press 'Enter' on virtual keyboard to confirm changes or 'Esc' to cancel the changes in Group Name field. Rotate the knob to go to next field.

#### Add Channel:

Rotate the knob to get the focus on 'Add Channel'. Press knob to add channels in the group. Immediately the dialog box for adding channel to the group will be displayed (Refer Figure 4.48 below). Initially focus will be on Select Channels to Add. Press the knob to display a list of all the channels. This list is an enumerated list with *On-Board* analog input Channels, followed by *Calculation Channels* followed *External Channels* and *onboard digital input channels*. Rotate the knob scroll through different channels. Press the knob to select the channel in focus. Once a channel is selected, the list is closed. Rotate the knob to move to next field.

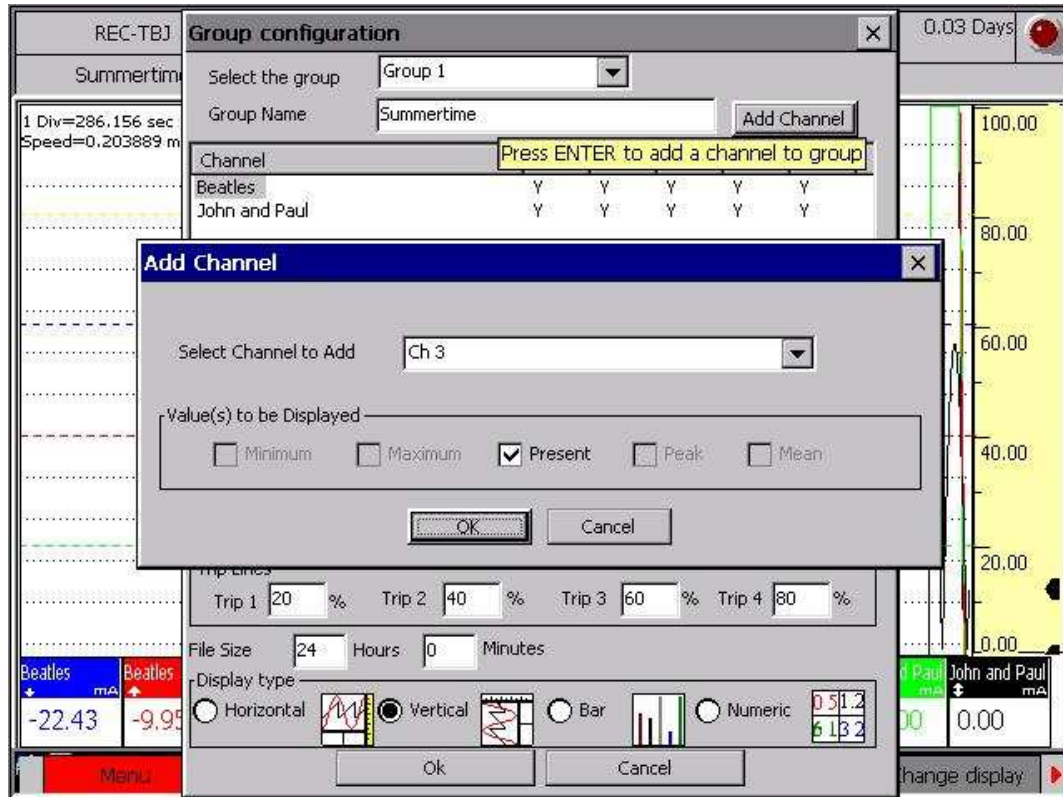

Figure 4. 448: Group configuration - Add Channel

#### *Values to be plotted:*

There are five different values that can be plotted for a channel and they are -*Minimum*, *Maximum*, *Present*, *Mean* and *Peak* value. Each value is considered as a separate channel. One or more of these may be selected for display if and only if they have already been selected for Recording Parameters in Channel's Configuration. Press the knob to toggle the state of the check boxes. If channel selected is not present in system then 'This channel is not available' dialog box is displayed. Rotate the knob to move to the next field. Press 'OK' to confirm your changes. Press *Cancel* to return without saving.

#### *Delete Channel:*

To delete a channel from the group, select the channel to be deleted from the list and then rotate knob until it comes to the 'Delete Channel' button. Press the knob to delete the channel. Rotate the knob to move to the next field.

#### *Edit Channel:*

If you want to view or edit one or more value of channels in addition to those that have been selected then select the channel in the list and press the knob. Rotate knob until it comes to Edit Channel. Press knob to edit channel. The dialog for editing channel is displayed as shown in figure 4.49 below. You can select one or more values to plot only if they are selected for recording

parameters. Press the knob to toggle the state of the check box. Press 'OK' to confirm your changes. Press 'Cancel' to return without saving the changes.

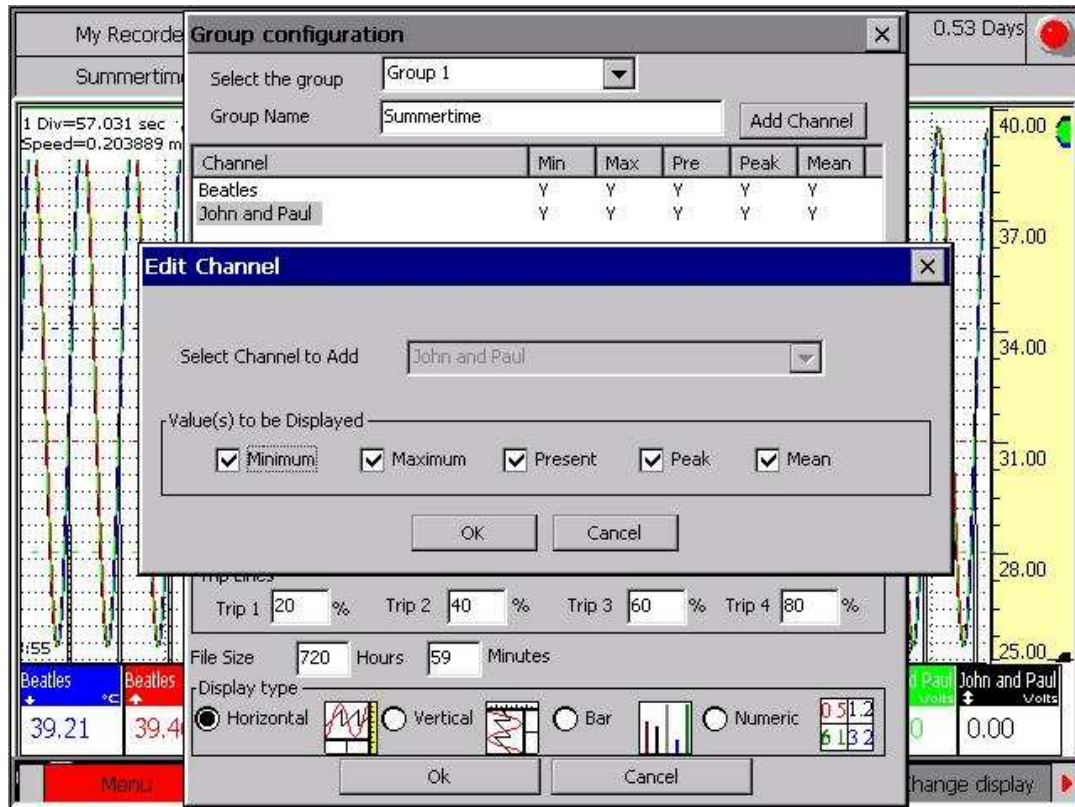

Figure 4. 49: Group configuration – Edit Channel

### Group Display:

Rotate the knob to shift the focus to the Group Display option. Focus will be on the radio button which indicates the present state of the Group Display. If a group is 'On', to make it 'Off' rotate the knob in the anticlockwise direction and then press the knob. If group is not configured in any of the combinational views then this change from 'On' to 'Off' is possible. Otherwise 'The group is configured in combinational view .cannot switched off 'dialog box will be displayed. If group is On then it will appear in Display->Groups submenu as enabled otherwise it will be disabled. The current group which is being displayed on screen can't be made off.

### Display Speed:

It's the speed with which the graph should shift to the left (Horizontal) or to the bottom (Vertical) of the screen. Minimum speed is 1 mm/hr and maximum is 734 mm/hr.

To select mm/hr rotate the knob and press it. Virtual keyboard will be displayed and enter display speed and Press Enter /Esc to confirm or cancel your changes.

### Trip Lines:

There are four trip lines per group. These are dotted lines which will be displayed on screen according to their percentage. This percentage varies from 0 to 100. These lines are different from grid lines.

Rotate the knob and when it comes to the 'Trip Lines' option, press it. With the help of virtual keyboard enter the percentage for the trip lines (in between 0 to 100). If trip line percentage is 0 then trip line won't be plotted.

*File Size:* Once a group file is opened, the data for the group will be recorded in the file for the time mentioned in these fields. The first box is for entering hours and the second box is for entering minutes. The hours can be any number between 0 and 1152 (included) and the minutes can be any number between 0 and 60 (not included). Once the group's data has been recorded in the file for the specified duration of time, the file is closed and a new file is opened for the group. There after the group's data will be recorded this new file. Both the hours and minutes field can not be set to zero.

*Display Type:*

There are four ways in which a group may be displayed.

1. Horizontal: In this the channel will be displayed with the time axis along the horizontal axis and the magnitude variation along the vertical axis. The direction of the trend is from right to left of the screen.
2. Vertical: In a vertical display, the trends of the member channels are displayed with time axis along the vertical-axis and the magnitude variations along the Horizontal-Axis. The direction of the trend is from top to bottom of the screen.
3. Bar: The channel values are displayed in the form of a bar chart. Below the bar the numeric value of the channel is displayed.
4. Numeric: In this only the channel values are displayed along with their name and units.

Rotate the knob and press it when the appropriate radio button is in focus to select the option. Rotate knob and to confirm your changes press 'OK' button else press 'CANCEL' button.

Group Files are generated with file name in the following format *Group\_time\_date\_Group name.bin*.

The time and date in the file is the same as the start time and date of the group. The Group name will be user given name of the group. The recorder can have up to 500 historic group files in the recorder depending, on the space available in the CF card. When the count of historic group files exceeds 500, it will be considered as a memory full condition. If the recorder is configured as 'Stop recording when memory is full', then recording will be stopped else the oldest file will be deleted. This is applicable if and only if recording is 'ON'.

Note:

1. The group currently being displayed can never have the option Group display set to off.
2. A minimum of one channel should be selected for a group.
3. Group, which is configured for display in any of combination views, can't be made off in group configuration.



## 4.5 Display configuration

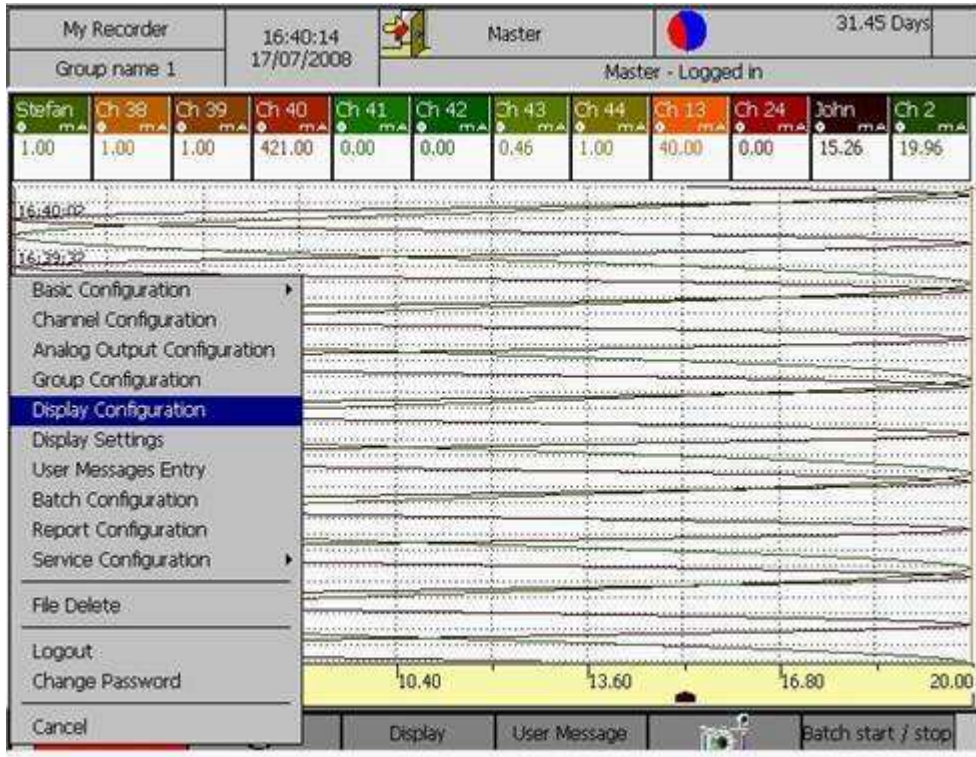

Figure 4.50: Display Configuration Navigation

Display Configuration allows you to define up to four combination views. Two to four groups can be viewed simultaneously with the help of combination views.

Select the Menu→ Display Configuration option.

### *Combination View:*

When you launch the 'Display Configuration' dialog, focus is on the 'Combination view' field. Press the knob and then rotate it to scroll from 'View 1' through 'View 4'. To select a particular combination view, press the knob.

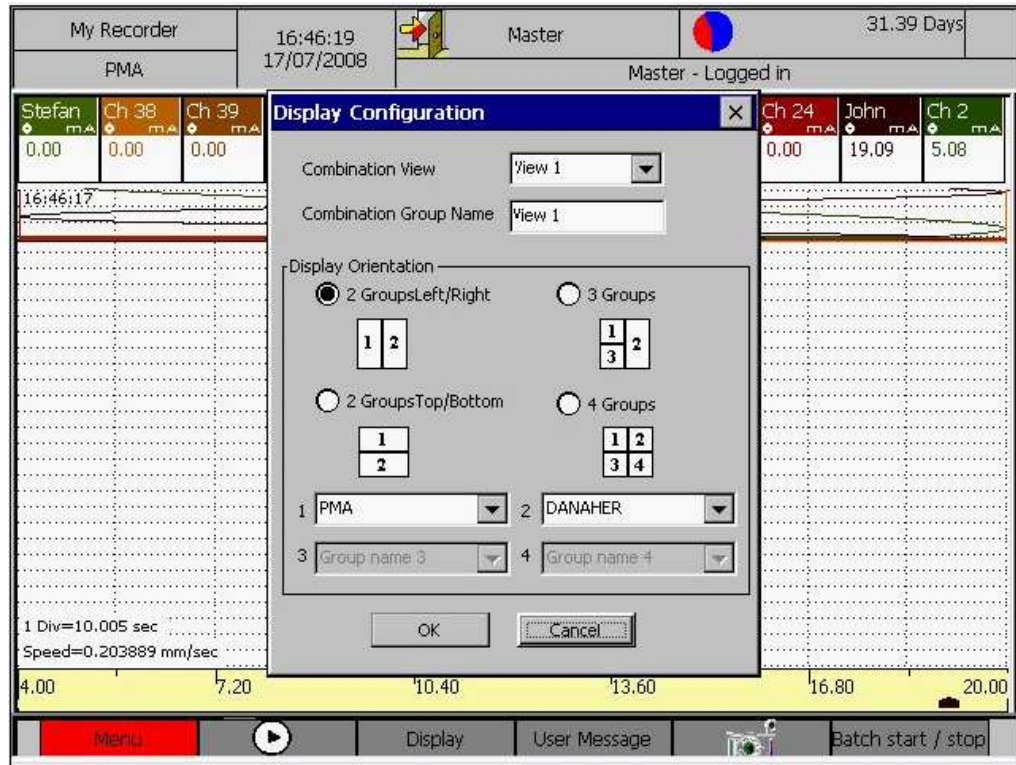

Figure 4.51: Display Configuration Dialog

*Combination Group Name:*

The name provided for each combination view in this field is displayed in the top status bar when the respective combinational view is being displayed.

Rotate the knob and select the 'Combination Group Name' field. Press the knob to display the virtual keyboard. Enter the name using keyboard and press the Enter/Esc key to confirm or cancel your changes.

*Display Orientation:*

There are four different orientations or the ways in which groups may be displayed in a combination view.

*2 Groups Left/Right:* This combination view consists of two groups. First group occupies the left half of the screen and second, right half of the screen. To select this option, rotate the knob (to bring focus to the corresponding radio-button) and press to select. You can select the groups you want to display in the above orientation. In the 'Display Orientation' option, four combo boxes are provided for selecting groups to be displayed. Out of that the first two combo boxes will be enabled. Rotate knob to go to the group selection combo box and press it. A list containing the groups configured with Group Display 'On' will be displayed. Rotate the knob to scroll through that list. To select any of the groups press the knob.

*3 Groups:* This combination view consists of three groups. First group occupies the top most left quarter of the screen, second group is positioned in the right half of the screen and third group

occupies the bottom most left quarter of the screen. To select this option, rotate the knob (to bring focus to the corresponding radio-button) and press to select. Out of four combo boxes, first three combo boxes will be enabled. Group selection is same as in *2 Groups Left/right* case.

*2 Groups Top/Bottom*: This combinational view consist of two groups. First group occupies top half of the screen while the second one occupies bottom half. To select this option, Rotate knob (to bring focus to the corresponding radio-button) and press to select. Out of the four combo boxes, first two combo boxes will be enabled. Group selection is same as in case of the other two options.

*4 Groups*: This combinational view consists of four groups. The screen is divided into four square s with each of the four groups occupying one of these quarters. To select this option, rotate the knob (to bring focus to the corresponding radio-button) and press to select. All the combo boxes will be enabled. Group selection is same as that in other cases.

Note:

1. You may select same groups for all the four orientations.
2. In case the screen legibility becomes poor in combination a view, icons representing value types (min., max., peak, mean or average) of each of the channels might not be shown.

To confirm changes press 'OK' else press 'CANCEL'.

## **4.6 Display settings**

This dialog box is for setting

1. background color of display
2. thickness of trend and trip line,
3. horizontal/vertical grid spacing

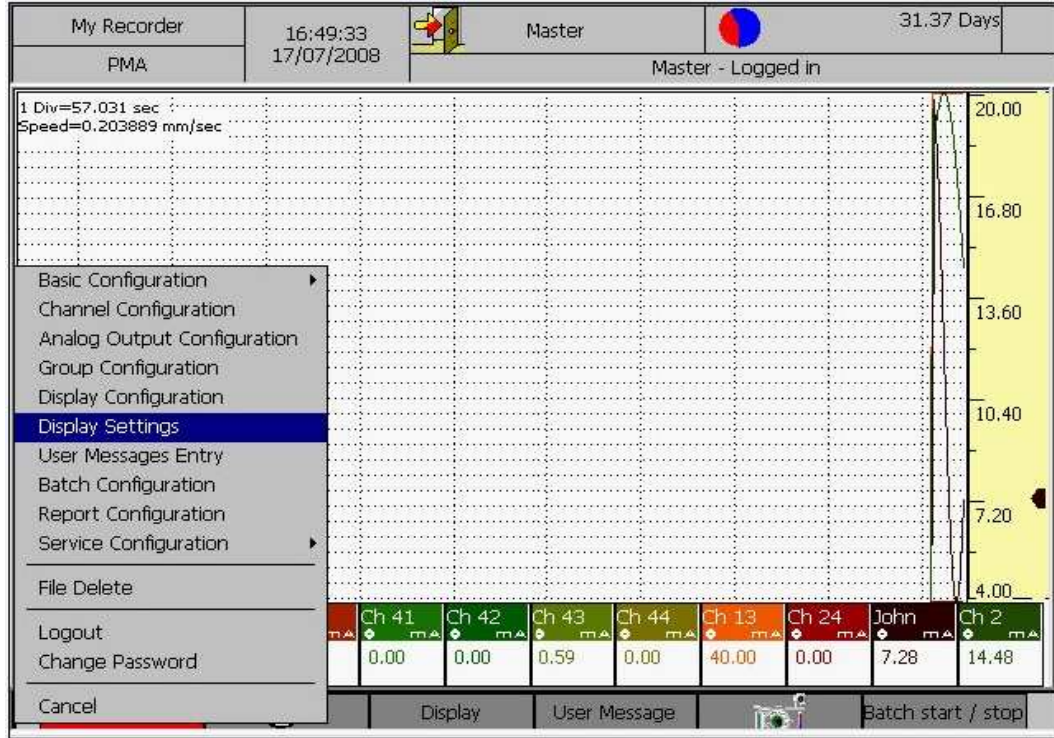

Figure 4. 452: Display Settings Navigation

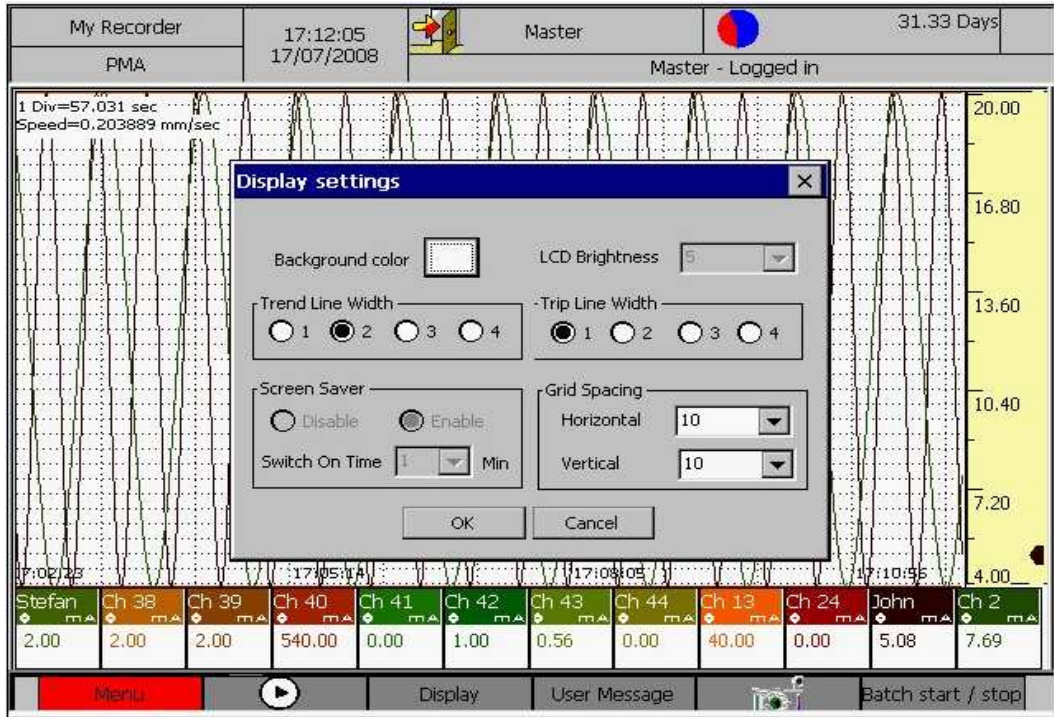

Figure 4. 463: Display Settings Dialog

*Background Color:*

When the dialog box is launched, focus is on the Background color field. Press the knob. A color dialog box will displayed (shown in figure 4.54 below). Initially focus will be on the radio button corresponding to the current background color. To select a background color that falls after the currently selected background color (as per the dialog layout), rotate the knob in clockwise direction and press the knob when the color of choice is reached. To select any color which comes before the currently selected background color, rotate the knob in anticlockwise direction and press it to make the new selection. To confirm your changes press 'Ok' otherwise press 'Cancel'.

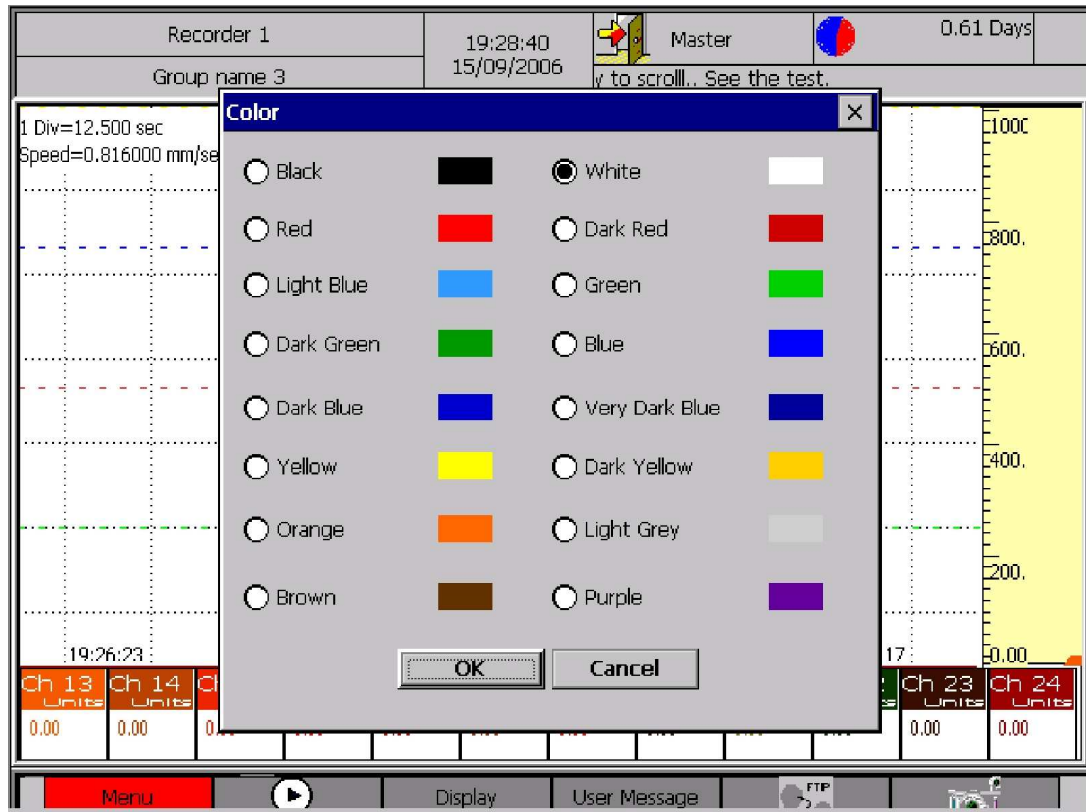

Figure 4. 54: Background Color Selection Dialog

*Trend Line Width:*

This is the width of the graph/trend lines in pixels. The focus will be on current trend width radio-button when the knob is turned to reach the 'Trend Line Width' group box. To select a trend line width that lies to the left of currently selected trend width option, rotate knob in anticlockwise direction and press it. To select a trend line width that lies to the right of currently selected trend width option, rotate knob in clockwise direction and press it.

*Trip line width:*

This is width of trip lines in pixels. Procedure for setting the trip line width is same as that of trend line width.

*Grid Spacing:**Horizontal:*

It's the distance between two horizontal grid lines in pixels. Rotate the knob and press it to display possible values .By rotating the knob, you may scroll through the list and select desired horizontal grid spacing by pressing the knob. It varies from 10 to 100 pixels.

*Vertical:*

The field specifies spacing of vertical grid lines in percentage of total diagram width (excluding scales). This value varies from 10 to 50. Selection procedure for the vertical grid spacing is same as that of horizontal grid spacing.

To confirm your changes press 'Ok' else 'Cancel'.

## 4.7 User Messages Entry

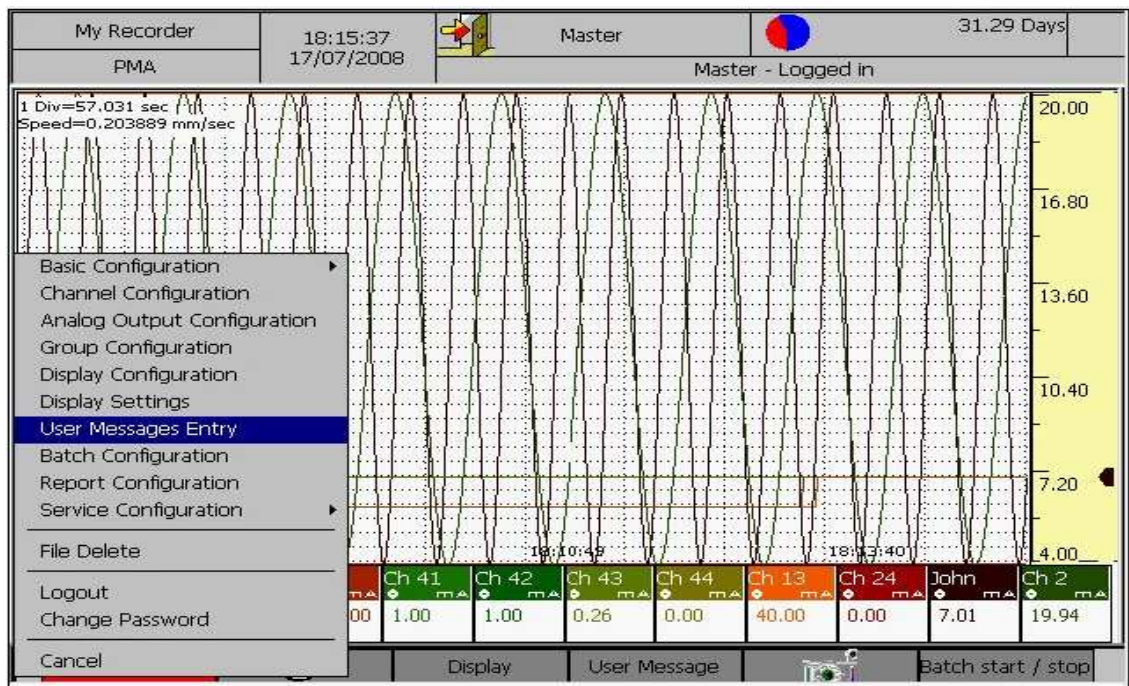

Figure 4. 55: User Message Menu

The 'User Messages Entry' menu option allows user to predefine up to 32 text messages.

### Procedure

1. Select the Menu → User Message Entry
2. Rotate the knob to select the boxes with serial number 1, 2, 3 . . .
3. Press the knob after highlighting the box to pop-up the onscreen keyboard. Enter the message using the keyboard and press enter when done.
4. When you are done with 8 messages rotate the knob to select the "NEXT" button and then press the knob to get the next 8 boxes to enter the message.
5. To see or edit the last 8 messages select the "PREVIOUS" button by rotating the knob and press the knob to get the last 8 messages.
6. Select and press OK to save all the messages.

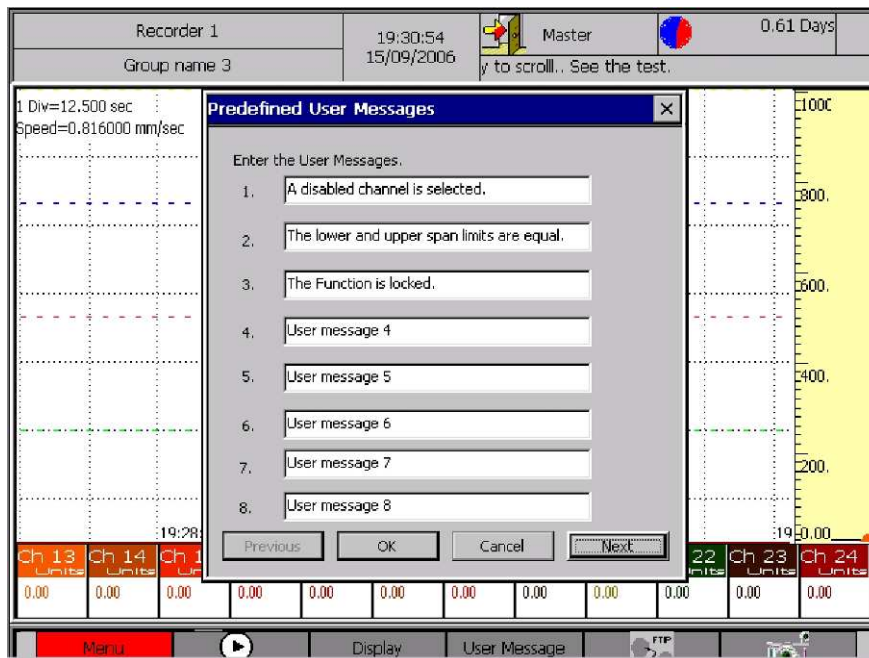

Figure 4. 56: User Messages

### 4.8 Batch Configuration

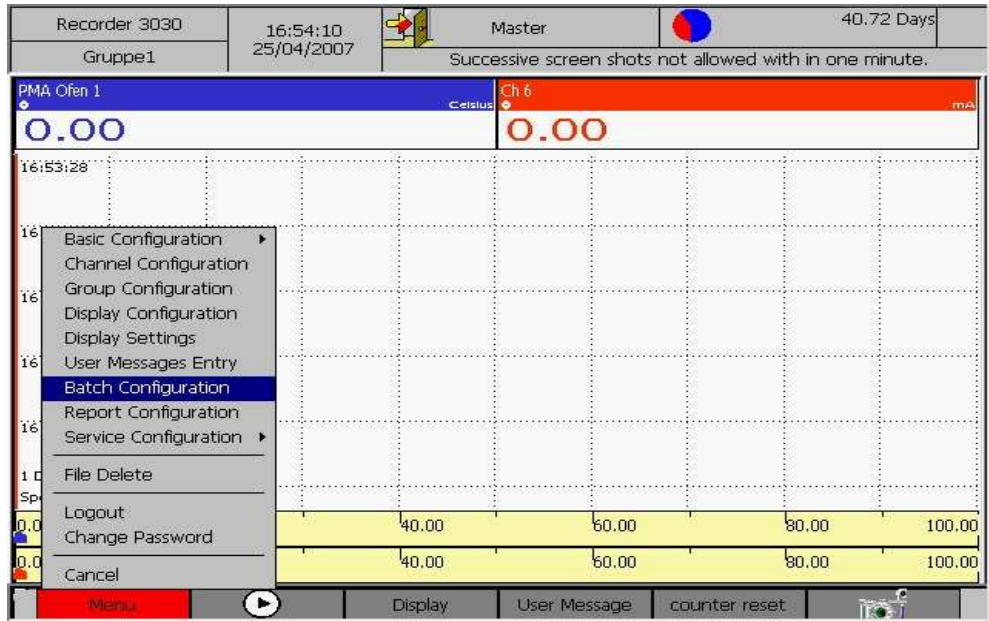

Figure 4. 57: Batch Configuration Menu

This option is to configure the recorder for generating Batch Reports. The Configuration options are as follows.

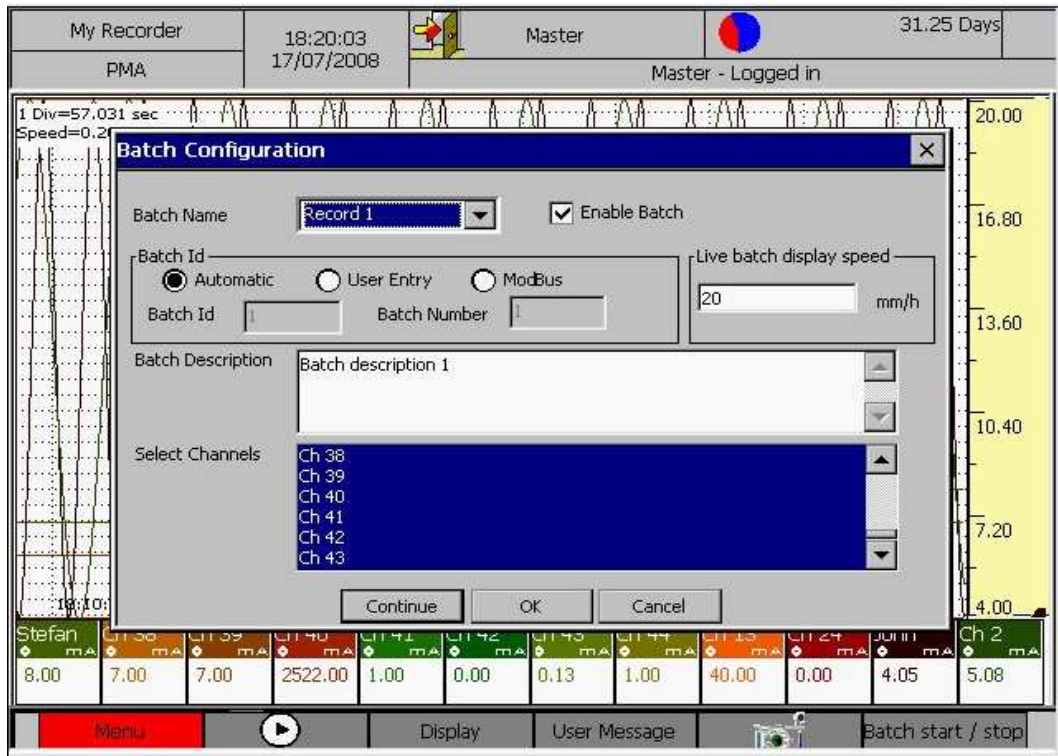

Figure 4. 58: Batch Configuration



1. **Batch Name:** The record type that is to be configured is selected from this combo box. There are four record types.
2. **Enable Batch:** To enable a record type this check box has to be selected. Without enabling the batch or record it cannot be configured for both recording and display.
3. **Batch ID:** The batch ID is a unique number that is used to identify a batch. It can be obtained by any of the following means: -
  - **Automatic:** - The recorder automatically generates The Batch ID. The ID number varies from zero to thousand and is cyclic. Each time a batch file is created for the same record, a different batch ID is generated.
  - **User Entry:** - The Batch ID is provided at the time of Batch Report Generation through the User Key. This option is used when the Batch Trigger is selected as 'Operator Entry'. If no Batch ID is specified using the user key and if any Batch ID is specified in this dialog it is used for generating the batch file. Otherwise the batch id is to be entered using the user key. Each time a batch is started the batch ID has to be provided. If this option is selected for either Analog/Digital signal trigger, it will be considered as automatic batch ID generation, i.e. the option will be considered as invalid and the recorder will generate Batch IDs by itself.
  - **Modbus:** - The Modbus master device provides the Batch Id. Each time a batch file is created for the record the batch ID is obtained from the MODBUS master.
4. **Batch Number:** Batch number is used to identify which batch the files belong to and it is used for generating the batch file names.
5. **Display Speed:** The batch graph is to be updated at the specified speed when plotting on the screen. Enter the speed in the box. It can take values between 1 and 734mm.
6. **Batch Description:** The description of the batch. The description can have a maximum of 1024 characters.
7. **Select Channels:** The channels in the recorder are listed and the channels to be included in the batch are selected from this list. Up to 44 channels can be selected for a batch.
8. **Continue:** To continue with the configuration. Continue button allows you to configure the batch triggers.
9. **OK:** To exit the dialog after saving the changes made.
10. **Cancel:** To exit the dialog without saving the changes made.

Procedure:

- Press the knob to view the list of records. Turn the knob to the right to scroll through the list. Each time a record is in focus, it will be highlighted in blue. Press the knob to select the record when it is highlighted.

- Turn the knob to the right to check the ‘Enable Batch’ to enable the Batch Report generation for that record.
- Turn the knob and press it to select the option for Batch ID generation, if Batch Id radio button selected is Automatic or Modbus Batch Id and Batch Number Edit fields are going to disable or if Batch Id radio button selected is User Entry then Edit fields are going to enable. Once the Batch ID option is selected enter the ID in the box provided. Turn the Knob to the right then the box will be in focus. Press the knob for the keyboard to be displayed. Enter the ID using the keyboard. Then press the knob when the focus is on the ‘Enter’ key of the keyboard.
- Turn the knob and press it to use keyboard to enter the Batch number.
- Enter the ‘Display Speed’ option in the same manner as explained for Batch ID.
- Enter the ‘Batch Description’ using the keyboard displayed on the screen as explained for Batch ID.
- Select the channels to be included in the batch report. Any number of channels can be selected. The selection procedure is similar to that of selecting records.
- To continue with the configuration press on the ‘Continue’ button, else to save changes and exit the dialog, Press on the ‘OK’ button when it is highlighted. To cancel and exit the dialog with out saving the changes press on the ‘Cancel’ button.

When the *Continue* button is pressed, another window is displayed as show in Figure 4.57 for configuring the batch triggers.

1. **Start/Stop Signal:** This option allows you to select the signal that is to be used for generating batches.
  - Digital Input: - A digital channel is used to trigger the batch recording.
  - Analog Input: - An analog channel is used to trigger the batch recording.
  - Operator Entry: - The Batch Trigger is generated using the User Keys in the short cut bar (Refer User Key Batch Start/stop).
2. **Select Signal:** The combo boxes from which the trigger channel is selected. The ‘Digital’ combo box will list all the Onboard digital input channels in the recorder. Similarly the ‘Analog’ combo box will list all the Onboard analog input channels in the recorder.
3. **Digital Input:** This option allows you to select the cause of the batch trigger for a digital channel. If the option ‘Low’ is selected, whenever there is a transition from high to low, batch recording will be started. Similarly when the option ‘High’ is selected, whenever there is a transition form low to high, batch recording will be started.
4. **Analog Input:** This option allows you to select the cause of the batch trigger for an analog channel. If the option ‘Min’ is chosen, whenever the minimum value of the channel becomes less than or equal to the specified value, batch recording is started. If the option ‘Max’ is chosen, whenever the maximum value of the channels becomes greater than or equal to the specified value, batch recording is started.

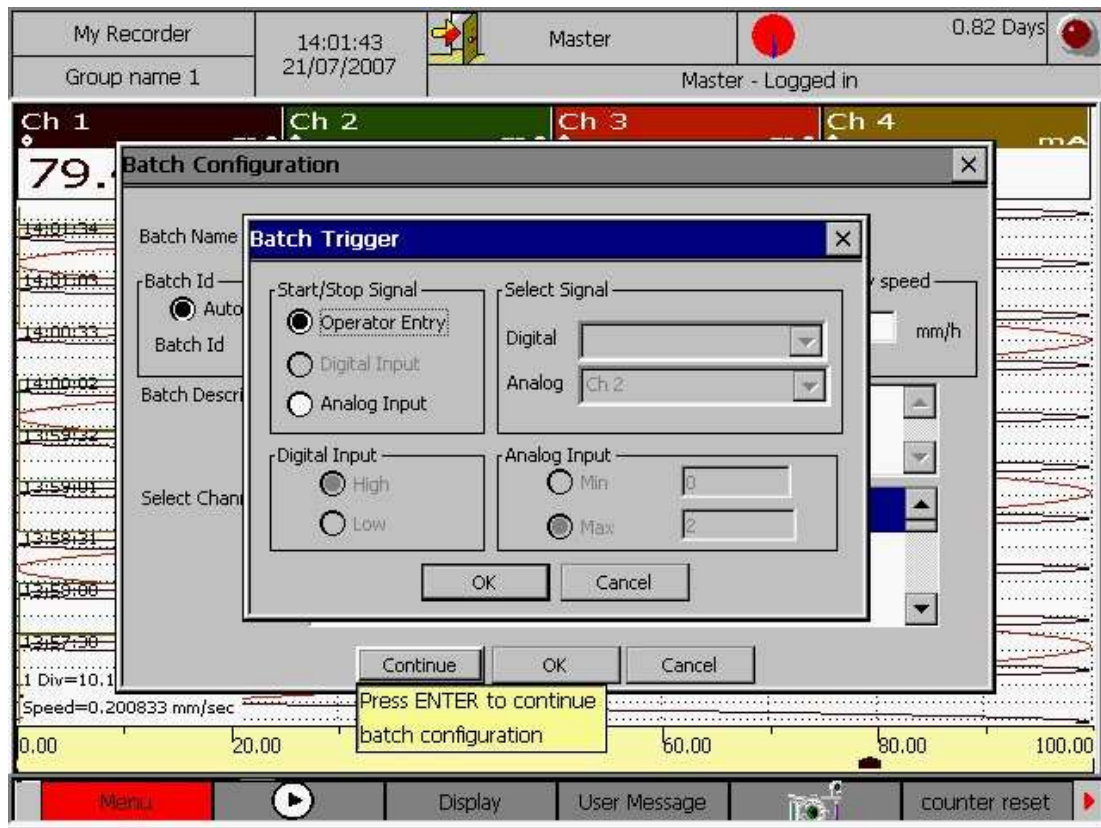

Figure 4. 59: Batch Trigger

#### Procedure:

- Turn the knob until the signal type to be used as batch trigger is highlighted. Press the knob to select it.
- When the start signal is selected as a digital channel, the field 'Digital' in 'Select Channel' will be highlighted. Press the knob to view the list of digital channels available. To scroll through the list turn the knob to the right. As you scroll through the list, the channel in focus will be highlighted in blue. To select a channel, press the knob when that channel is highlighted. Turn the knob to the right to exit from the list, the focus will be on the 'High' radio button in the 'Digital Input' section. If you need to select 'Low' turn the knob to the right. The 'Low' will be highlighted, then Press the knob.
- When the start signal is selected as an analog channel, the field 'Analog' in 'Select Channel' will be highlighted. Press the knob to view the list of analog channels available. To scroll through the list turn the knob to the right. As you scroll through the list, the channel in focus will be highlighted in blue. To select a channel, press the knob when that channel is highlighted. Turn the knob to the right to exit from the list, the focus will be on the 'Max' radio button in the 'Analog Input' section. The box corresponding to this option will be enabled. Enter the value in this box using the key board. If you need to select 'Min' turn the knob to the left. The 'Min' will be highlighted, then Press the knob. The box next to 'Min' will be enabled. Enter the value in this box using the keyboard.

- To activate and save the setting press the 'OK' button, else press on the 'Cancel' button.

Only the present values of channels will be recorded in the batch files. The Batch files generated will have file names in the following format *Batch\_BatchID\_BatchNumber\_Time\_Date.bin*. The time and date is the same as the start time of the batch. The recorder can have up to 500 batch files residing in the CF card memory at a time. Once this count is exceeded, the recorder will consider it as a memory full condition. If the recorder is configured as 'Stop recording when memory full', it will stop recording, else it will delete the oldest file and continue with recording. This is applicable if and only if recording is 'ON'.

## 4.9 Report Configuration

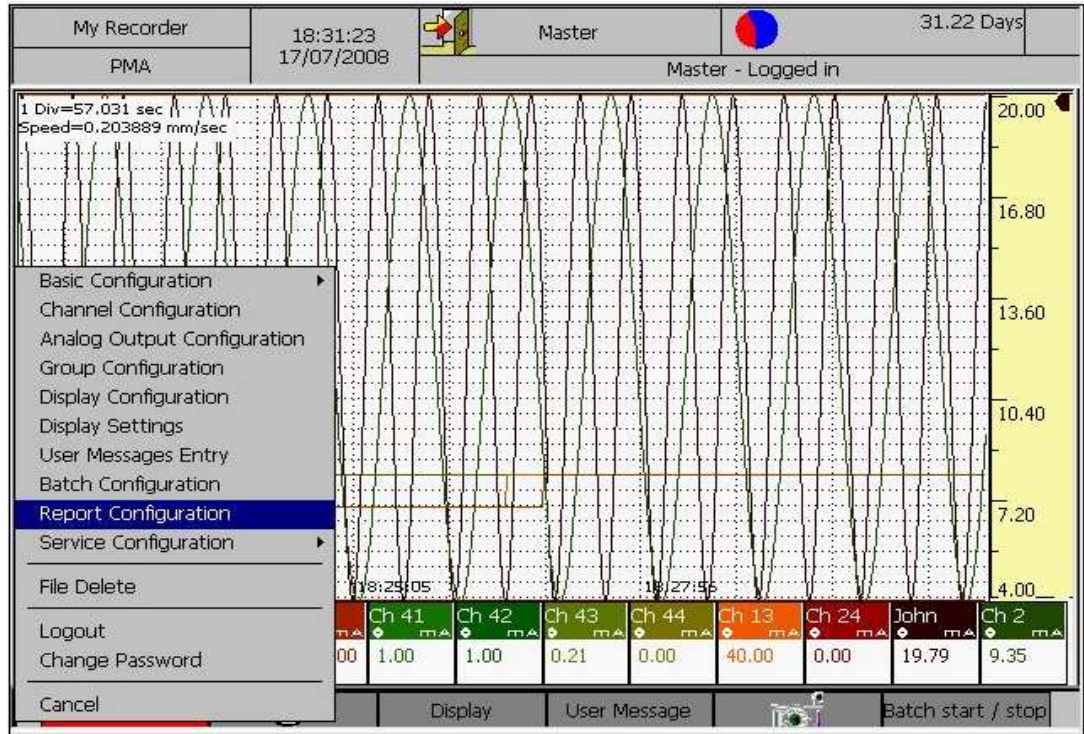

Figure 4.60: Reporting Configuration

The Reporting Function option allows you to configure the recorder for generating reports for channels when recording is 'ON'. Report generation can be configured for all the channels.

- Channel:** The combo box lists all the channels that have been configured in the recorder. The channel for which the report is to be generated is selected from this list.

2. **Intervals:** This option allows you to set, how often the reports have to be generated. For a channel multiple intervals can be selected. The option provides the following: -
- **Hourly:** Reports are generated after every hour.
  - **Daily:** Reports are generated at the start of every day.
  - **Monthly:** Reports are generated at the start of every month.
  - **Annually:** Reports are generated at the start of every year.
- After each interval the required report will be generated.
3. **Data Types:** - A report contains any of the values or any combination of the following values: -
- **Actual Value:** The current value of the channel at the time of report generation is entered in the file.
  - **Minimum Value:** The minimum value obtained for the channel during the specified time interval is entered in the report. For example: - For hourly reports, the minimum value received with in the hour is entered in the file. The time at which this value was obtained will be entered in the report files.
  - **Maximum Value:** The maximum value obtained for the channel during the specified time interval is entered in the report. For example: - For hourly reports, the maximum value to be received with in the hour is entered in the file. The time at which this value is obtained will also be entered in the report files.
  - **Peak Value:** The peak value is entered in the report file. The peak value is calculated as the difference of the minimum and maximum value obtained for the channel in the specified time interval.
  - **Mean Value:** The mean value is entered in the report file. The mean value is calculated as the mean of the minimum and maximum value obtained for the channel in the specified time interval.
  - **Sum:** The sum value is entered in the report file. The sum value is calculated as the sum of the minimum and maximum value obtained for the channel the specified time interval.

To obtain the Peak value, mean value and Sum value both minimum value and maximum value has to be selected. The reports are generated with the interval type in their names. For example: - *Hourly* reports will have the following file name format *Hourly\_channelID\_Time\_Date.bin*. The time and date is same as the time at which the report was generated. At a time the recorder may have up to 500 files in the CF Card. When the number of files exceeds 500, it is considered as memory full. For FIFO, files will be deleted and for 'Stop Recording', the recorder will stop recording files. This is applicable if and only if recording is 'ON'. The window for configuring the reports is as show in the Fig.4.61 below.

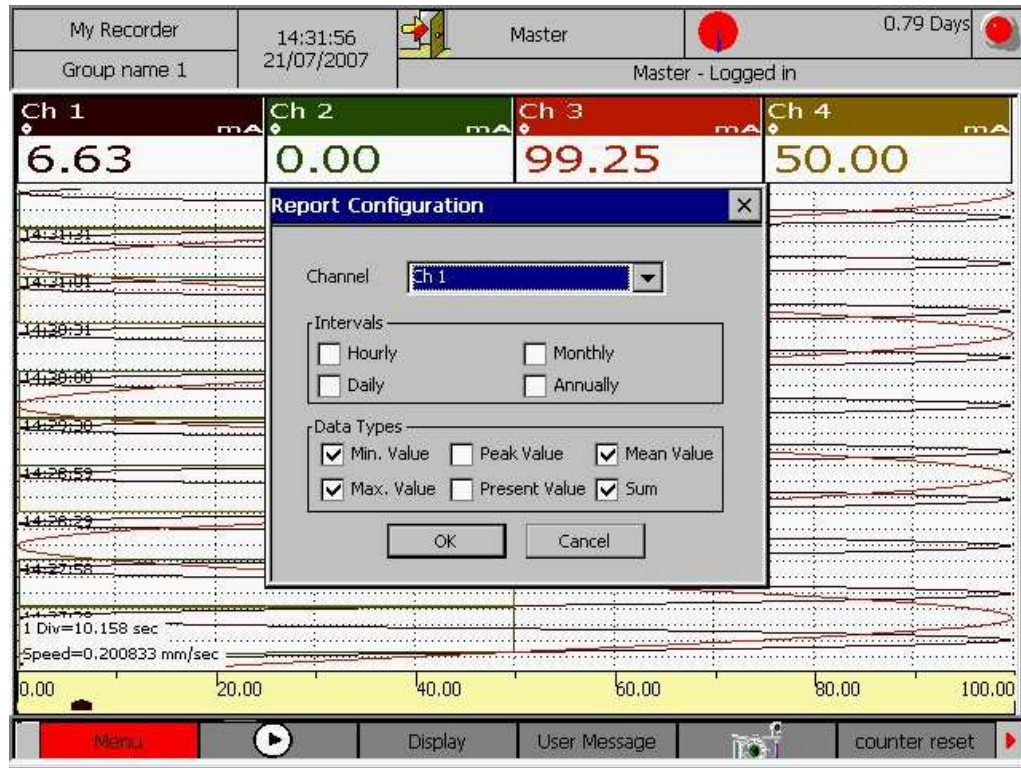

Figure 4.61: Reporting Configuration

### Procedure

1. Select the Menu→ Report Configuration option.
2. Select the channel by rotating the knob till the required channel is highlighted. Press the knob to select.
3. Rotate the knob to select the intervals at which report is to be generated. You can select multiple interval options. Check the selected options.
4. Data types can be selected in the same way as explained above.
5. Rotate the knob to select the OK button and then press the knob to confirm the setting. This is to activate and save the settings. To cancel the configuration changes press on the 'Cancel' button.

## 4.10 Service configuration

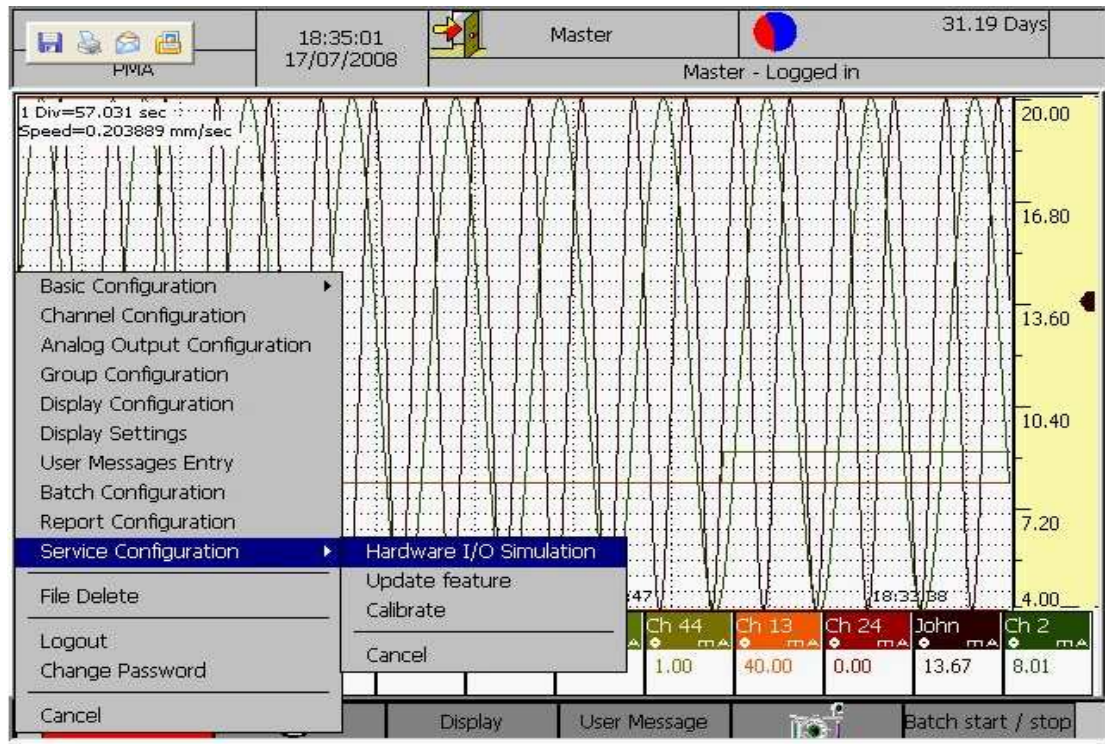

Figure 4. 62: Service Configuration

### 4.10.1 Hardware I/O Simulation

Operator can configure system for simulation mode where in all the actual physical channels (i.e. On-Board and External Channels) are simulated by the system itself. User can configure to feed each of the channels with a particular signal type such as sine wave, square wave, triangular wave etc., along with a configurable duty cycle (time period).

All the signal processing related to each of these channels (as per the channel configuration) is applied to the value fed from the simulated signal. All the features of the system work in the simulation mode as they work in the normal mode, except for the fact that the source of data is simulated internally.

In the Hardware IO Simulation dialog, the default focus is on the *Select Signal Type* field.

*Select Signal Type:*

Simulation mode is used to define feeder wave forms for On-Board analog Input channels , External channels and Onboard digital input channels. Select *Onboard Channels* in this filed to

define feeder waveforms for On-Board Channels and select *External Channels* in this field to define feeder waveforms for External Channels.

*Onboard Analog Input Channel 1 through Onboard Analog Input Channel 12:*

The dialog shows 12 rows each for one On-Board AI channel (refer figure 4.63 below). Each channel name is followed by two columns-1) the type of signal/waveform to be fed and 2) time period of the waveform, if applicable. Different waveforms available are as follows: Sine wave, Square wave, Triangular wave, Random wave and Constant wave. Time period is specified in seconds and is input using a virtual keyboard.

Feeder waveforms for *External channel 1 through External Channel 12* can be defined in a similar way. Recorder can be made to work in either *Simulation Mode* or in *Normal Mode* by selecting the appropriate radio buttons at the bottom.

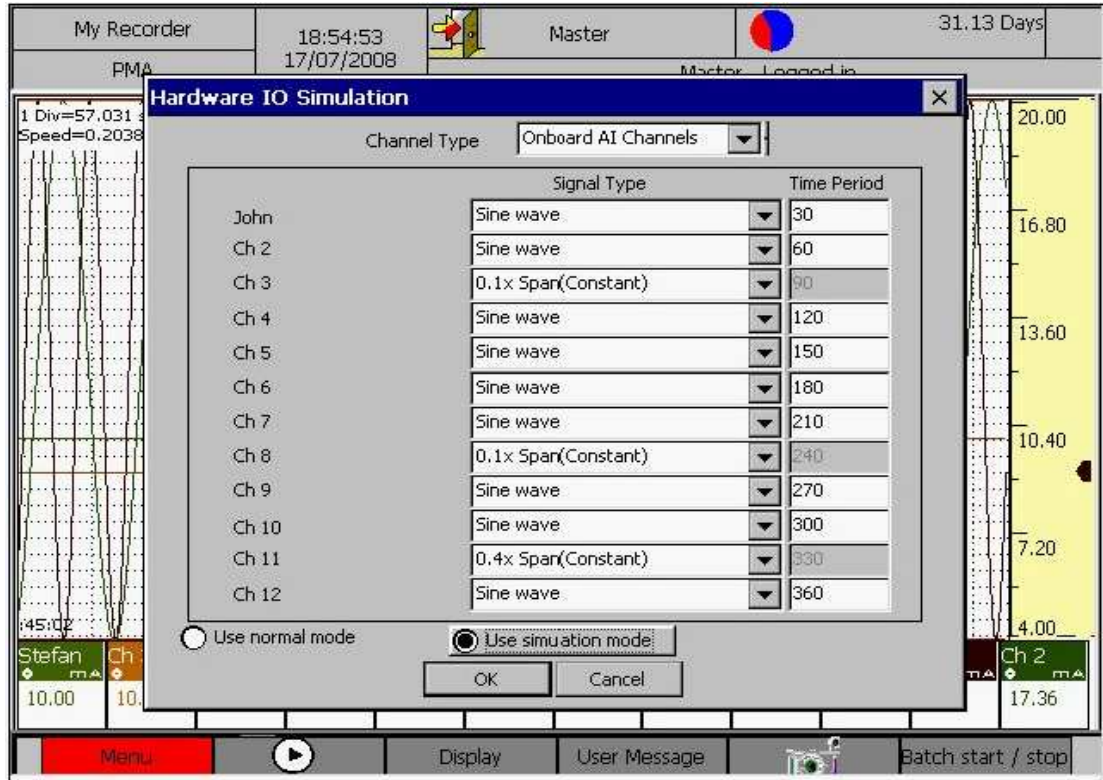

Figure 4. 63: Hardware I/O Simulation

*Onboard Digital Input Channel 1 through Onboard Digital Input Channel 8:*

The dialog shows 8 rows each for one On-Board DI channel (refer figure 4.63(a) below). Each channel name is followed by two columns-1> the type of signal/waveform to be fed and 2> time period of the waveform, if applicable. Different waveforms available are as follows: Square wave, Square High (Constant) and Square Low (Constant). Time period is specified in



seconds and is input using a virtual keyboard. In Signal Type column if the Signal type is other than Square wave the corresponding Time period column will be disabled.

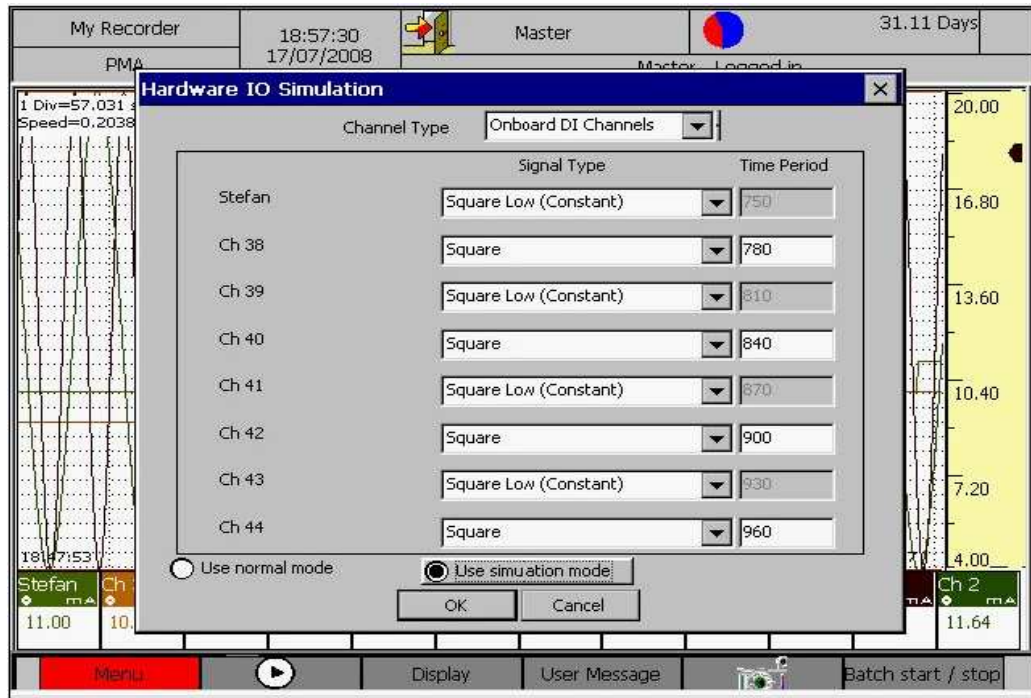

Fig 4.63(a) Hardware I/O Simulation

When user changes from simulation mode to normal mode and there is a mismatch between the configuration of recorder and available hardware, then an invalid configuration dialog is displayed (similar to the dialog which is discussed at 3.1 Main screen and toolbar overview).

#### 4.10.2 Update feature

Using this user (with Master/Permission level 6 login only) can update the following features of recorder.

1. Batch process
2. Calculation channels
3. External channels

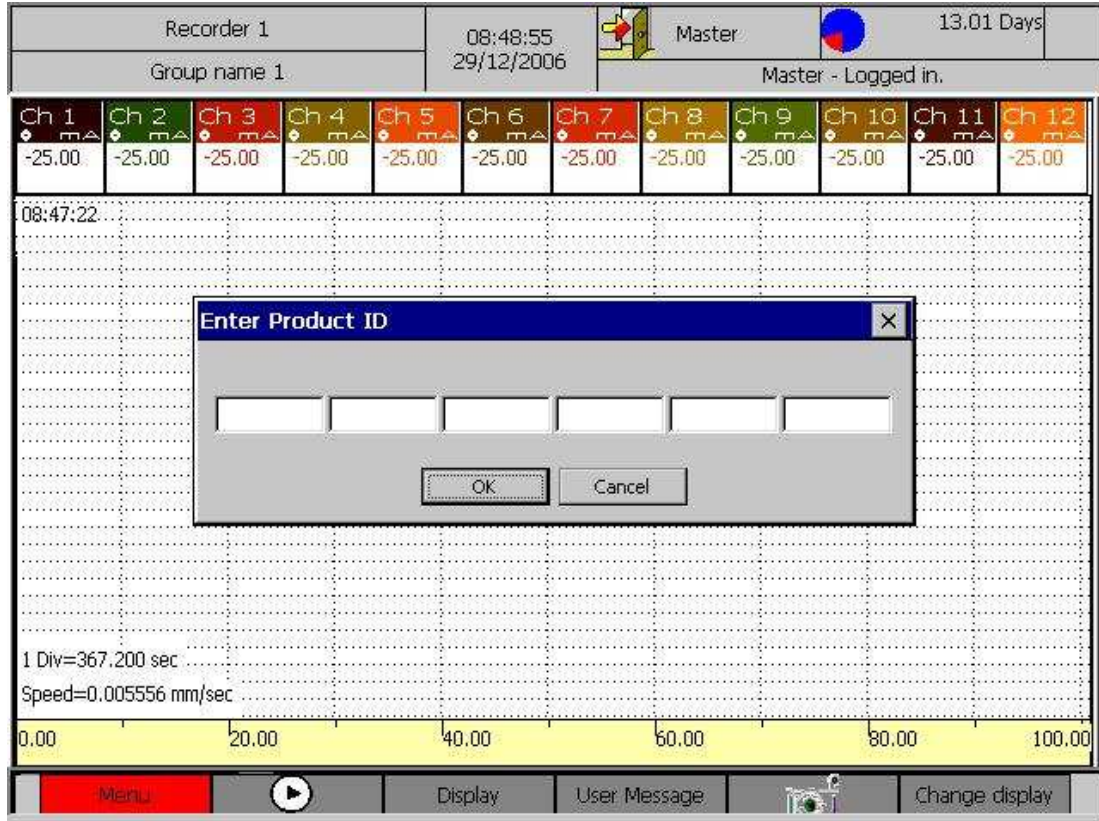

Figure 4. 64: Update Feature

The product ID that you get with your recorder is unique. It also represents the features available with your recorder. You are issued a new Product ID key when you go for a feature update

#### Procedure

1. Select the Menu → Service Configuration → Update feature option
2. Enter new product ID to update feature.
3. Restart the device.

### 4.11 File Delete

This option allows user to delete unwanted files. By selecting 'file delete' option from the *Menu*, 'File Delete' dialog is shown as in figure 4.65 below. You can delete the following types of files here:

- Batch Files
- Historic Files
- Report Files

- Screen Shot Files
- Startup Image Files

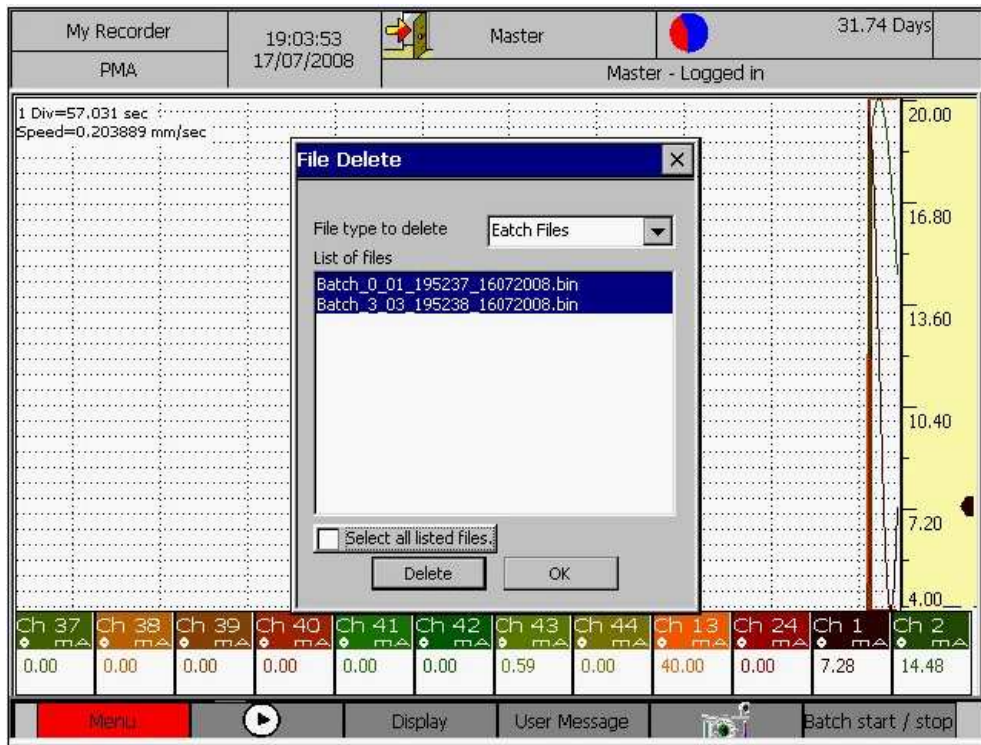

Figure 4. 65: File Delete

#### Procedure

4. Select the Menu → File Delete option
5. Select the type of file to delete from the *File Type to delete* field.
6. Rotate the knob to highlight the file and select it by pressing the knob. This List is a multiple selection list. You must press the knob to select a de-selected field and to de-select an already selected field by bringing focus on that particular item in list. To exit from the list box, you must make a long press.
7. Rotate and highlight the DELETE button and then press the knob to delete the selected files.
8. All listed file can be deleted at once by checking the “Delete all listed file” box.

## 4.12 Logout

In addition to the automatic logout, user (who is already logged in) may manually logout from his session by using this option. By pressing the logout button the current login session is closed and a dialog is shown as below.

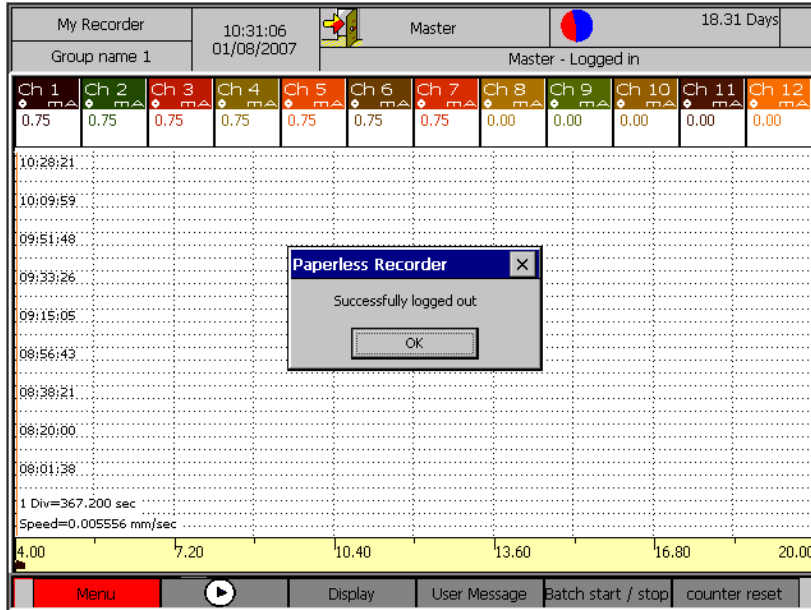

Figure 4. 66: Logout Confirmation Box

### 4.13 Change Password

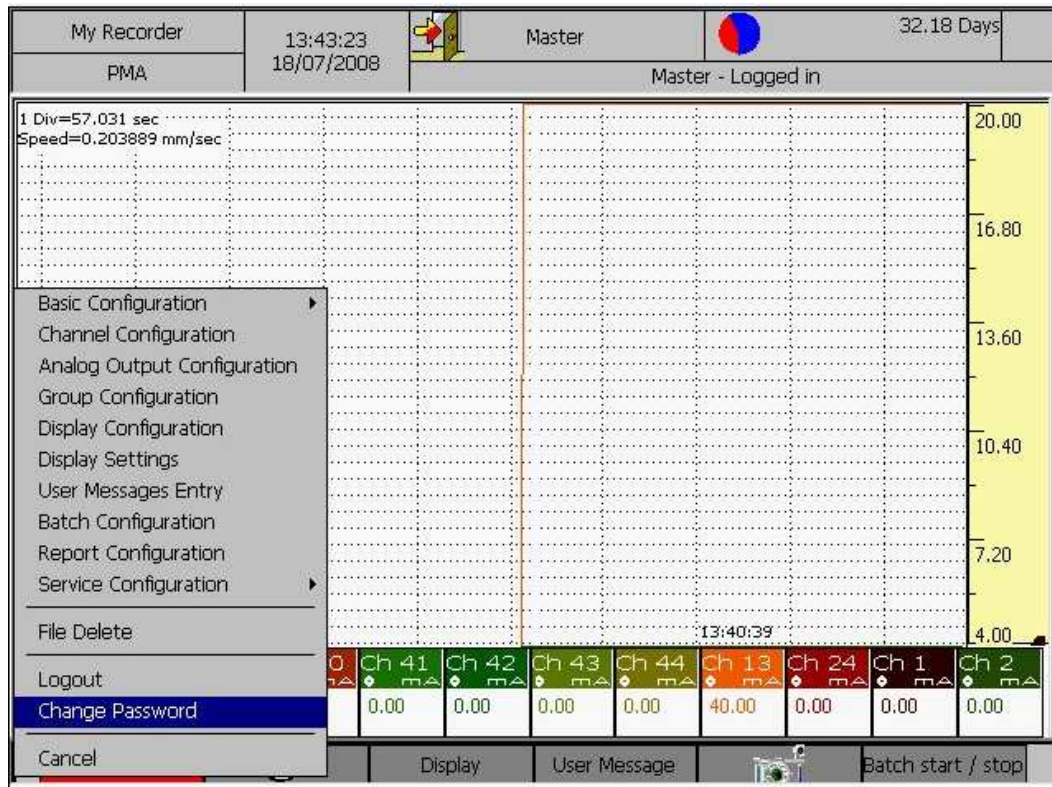

Figure 4. 477: Change Password

By selecting this option the screen will be updated as follows.

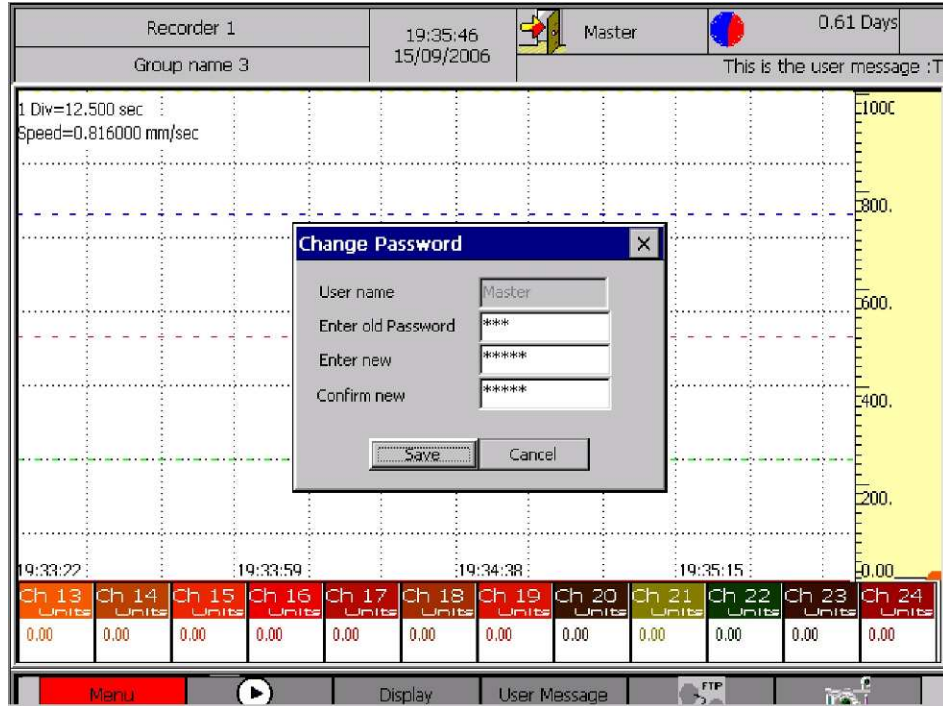

Figure 4. 68: Change Password

### Procedure

1. Select the Menu→ Change Password option.
2. Rotate the knob and press it at the old password box. Onscreen keyboard will pop-up to enter the old password. Press enter after entering the old password.
3. Enter the new password in the same way as explained above.
4. Confirm the new password in a similar fashion.
5. Rotate the knob to highlight the SAVE button. Now press the knob to save the new password.

## 5 Display

By selecting Display button in the short cut bar the screen will be displayed as follows

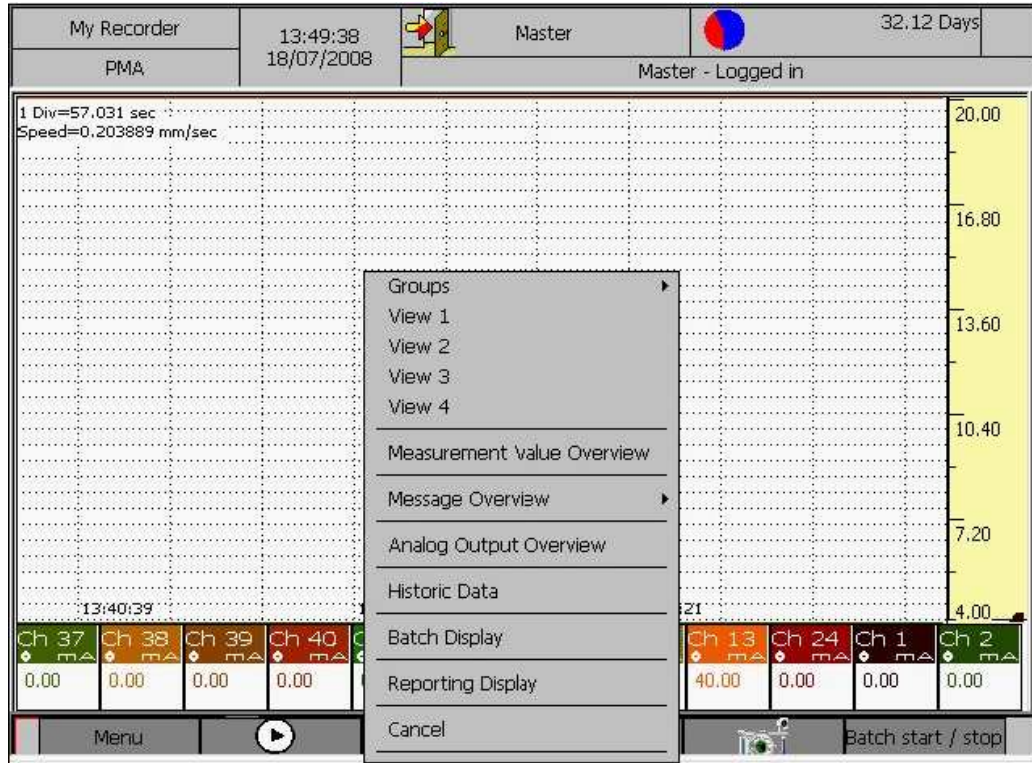

Figure 4. 489: Display Menu

### 5.1 Group

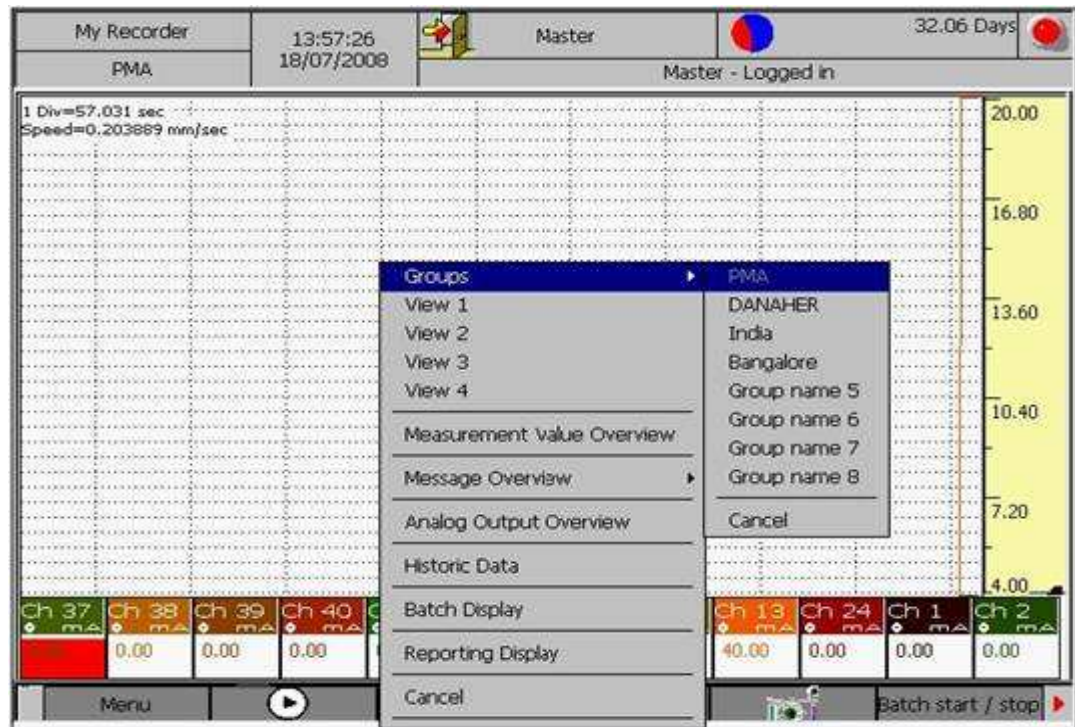

Figure 5. 1: Group Display Selection Menu

Here you may select any of the group which are enabled in group configuration to be displayed on the screen. The groups, whose group display is Off in group configuration, are grayed in Groups submenu.

Rotate the knob and go to the 'Display' short cut key. Press the knob. The Display Menu will be displayed. Rotate knob in clockwise direction and go to the 'Groups' option. Press the knob. One pop up menu will be displayed, which contain all the configured groups. Rotate the knob in clockwise direction to select any group from Group 1 to Group 8. Else rotate it in anticlockwise direction to select any of the group from Group 8 to Group 1. Then press the knob. Current group and those groups, which are off in group configuration, will be in disabled state.

Select Display -> Group -> (any group among configured groups)

Group's name will be displayed in the status bar.

Depending upon display type graph for the group will be displayed

*Horizontal Trend Display:*

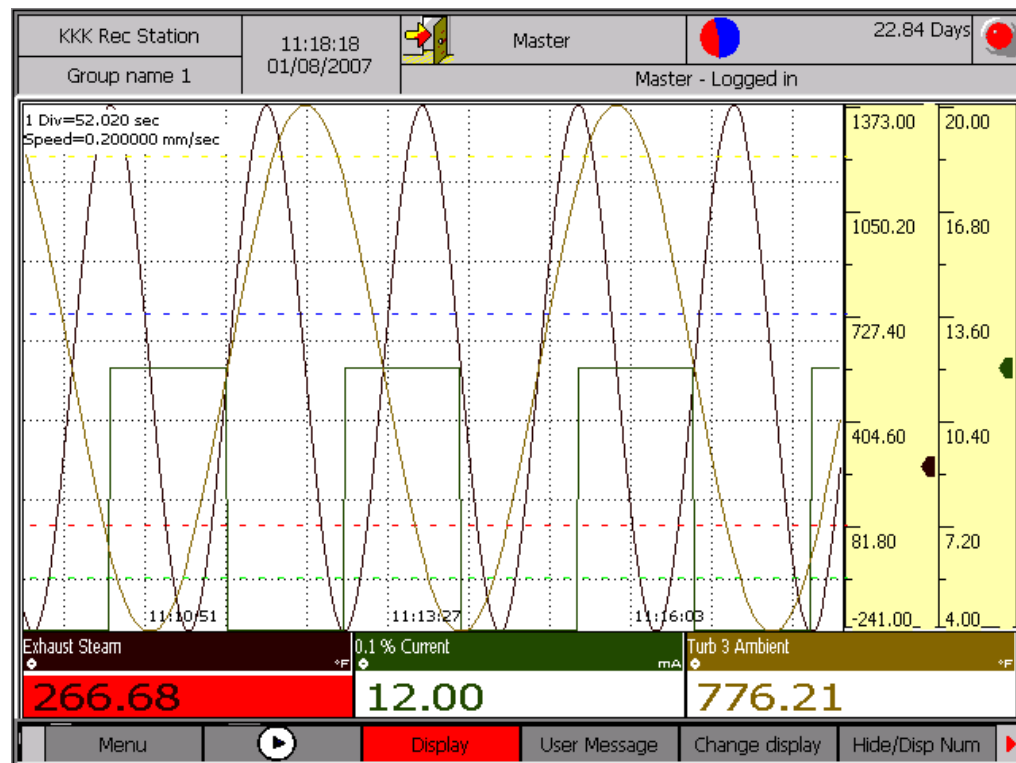







Figure 5. 2: Group Display - HORIZONTAL

The diagram scrolls from right to left in case of Horizontal trends, with scales located to the extreme right. Each member channel trend is plotted with its selected color and the common pixel width specified in display settings. The background color also comes from the display settings. Trip lines are shown as specified in group settings for the group in display. Trip lines have fixed colors of GREEN, RED, BLUE and YELLOW for trip lines 1 through 4 respectively (of Group Configuration dialog).

For channels with scales enabled, scales have a marker (with same color as the color of channel). In case different channels on display with scales enabled have same display ranges and scale divisions, they share a common scale but independent markers (markers always indicating the present value of associated channel).

According to the number of divisions set in the channel configuration, scale divisions are displayed. First division (topmost) represents the upper limit and last division (bottom) represents the lower limit. Even if some value of the channel is above its upper limit, it is plotted as upper limit of the channel but its correct value will be displayed in numeric display section of corresponding channel.

Numeric display section consists of the channel's name, unit, value and a *value type indicator*. In horizontal trend display, numeric displays are positioned just above the shortcut bar. There are five *value type indicators* (icons representing each value-Maximum, Minimum, Peak, Present and Mean) of each channel.

Value	Icon
Present value -	
Max value -	
Min value -	
Peak value -	
Mean -	

Top left corner of the display shows the following information:

1. Time width of one division in seconds.
2. Display scrolling speed in mm/sec.

#### *Vertical Trend Display:*

Apart from orientation, everything remains same in a Vertical Trend Display with respect to Horizontal Display. Numeric display part is displayed on top side of screen and scales with markers are displayed at the bottom side of graph. Time width of one division and Display scrolling speed are shown at the bottom left corner. Refer figure 5.3 shown below.



For vertical and horizontal trend display if an alarm occurs for any channel then corresponding numeric display section is shown blinking with RED in background.

*Grid Timings:* Time at which data is captured is displayed after one or more horizontal grids .In order to avoid congestion of timing text, time stamps are displayed in such a way that distance between two timing texts in vertical display is at least 30 pixels. Time difference in seconds between two time stamps is reasonably constant with exception where sometimes it might vary because of odd display speeds (a maximum variation of 1 second should be expected here).

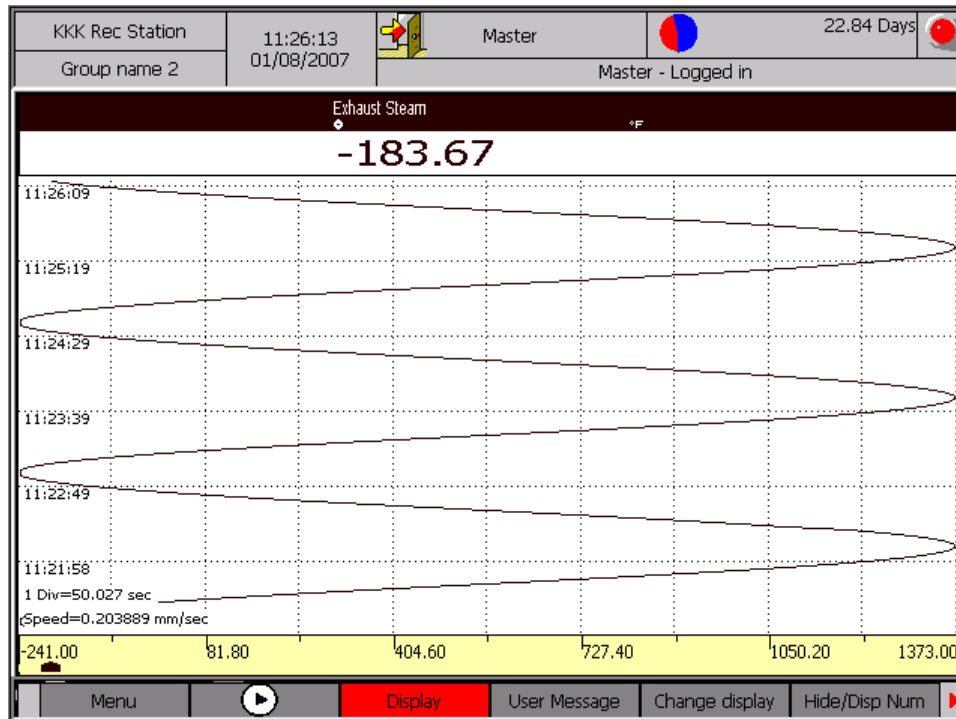

Figure 5. 3: Group Display - VERTICAL

### *Bar Graph:*

Complete screen is divided into sections equal to the number of channels. In each section scale with divisions and a bar representing current channel value is plotted. Channel values are displayed below each bar along with unit. The icon for *value type indicator* for respective channel is displayed next to unit. If an alarm is configured for a channel then red alarm line indicating alarm value is displayed on the scale. When alarm occurs then channel's value is blinked (red and background color alterations). Refer figure 5.4 below.

### *Numeric Displays:*

All the channels configured in a group are displayed along with their units. If an alarm occurs for a channel then channel's value will be displayed with alternating red and white backgrounds to give a blinking effect. By pressing user key Change Display you can view same group's graph in all four display type one after another. Refer Figure 5.5 below.

Change display user key can only be used with groups only and not with combinational views.

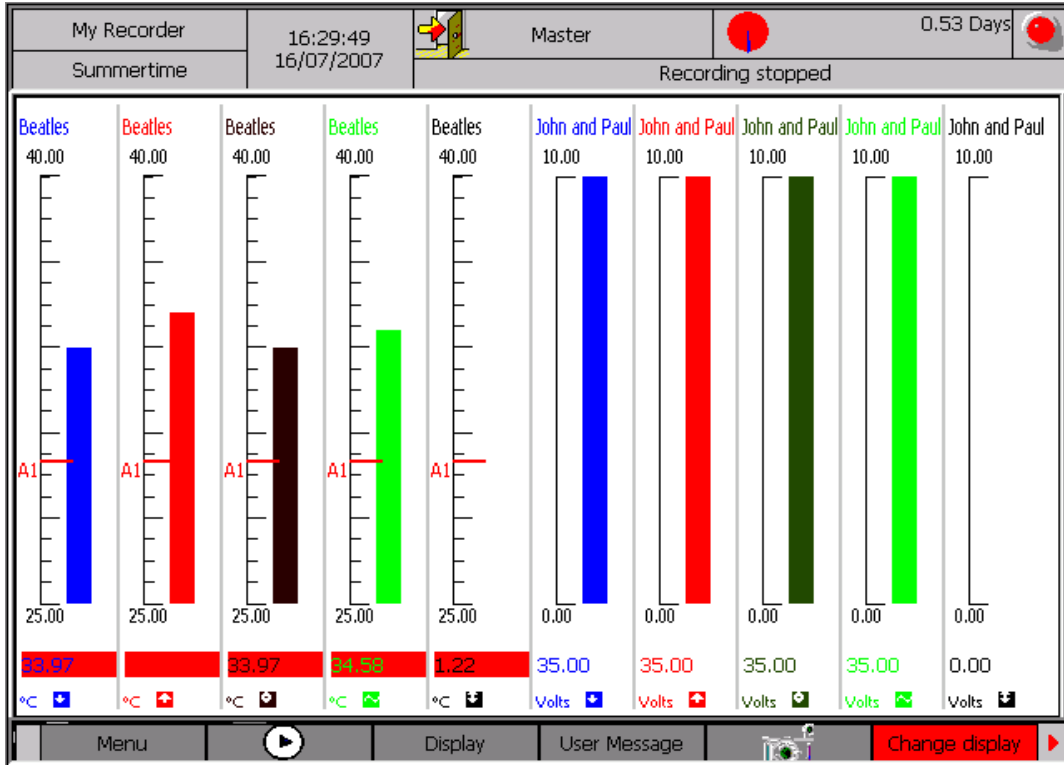

Figure 5. 4: Group Display – BARGRAPH

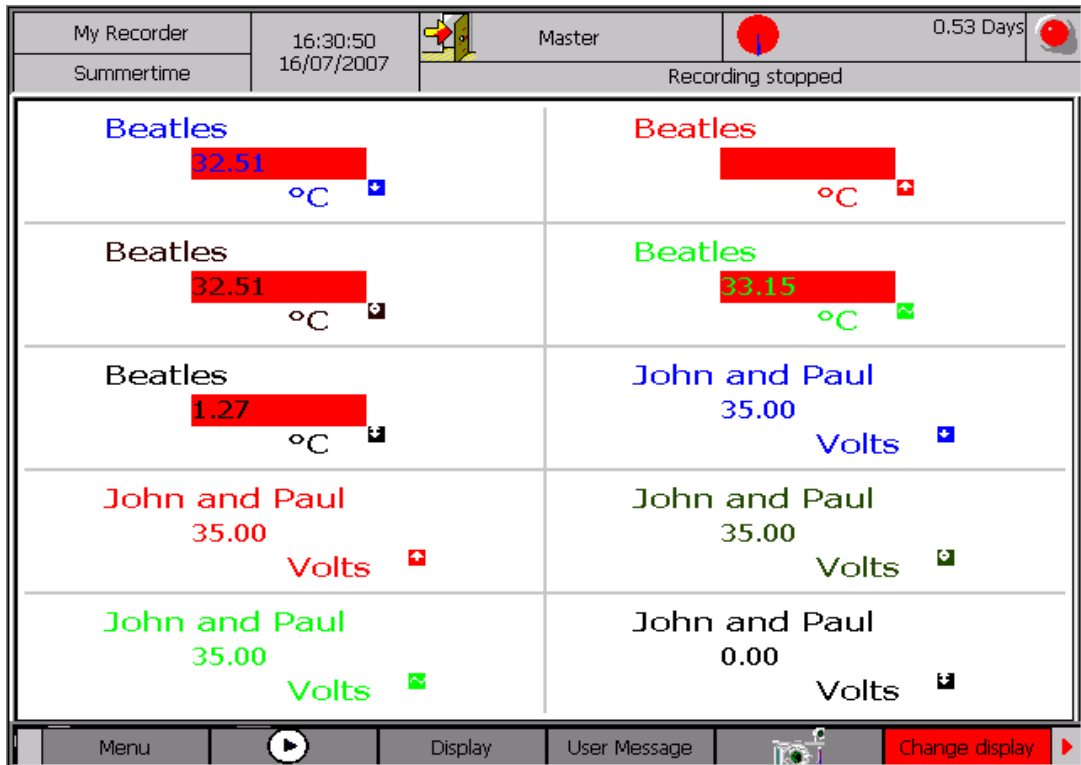

Figure 5. 5: Group Display– NUMERIC DISPLAY

## 5.2 Combination Views

Each combinational view includes 2 to 4 groups in a single screen as configured in *Display Configuration*. You can switch to any one of the four configured combination views at the following navigation path:

Select Display → Combinational View1

Select Display → Combinational View2

Select Display → Combinational View3

Select Display → Combinational View4

*Combination View (2 Groups Left/Right):*

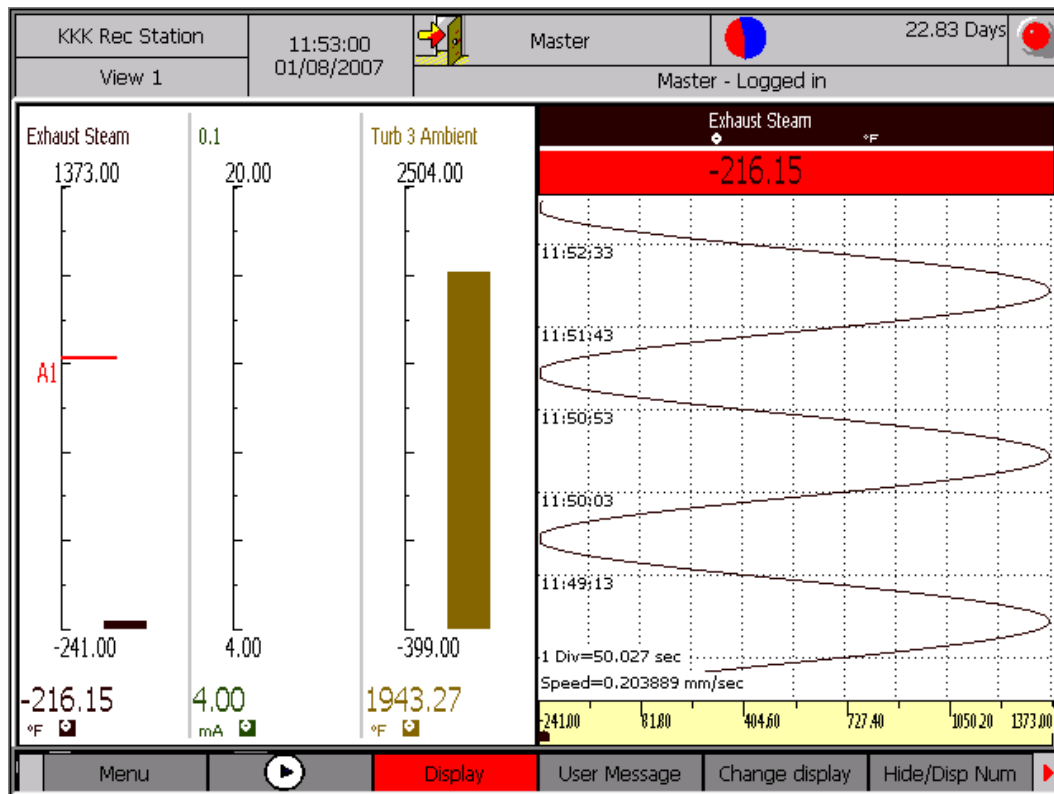

Figure 5. 6: Combination View – 2 Groups Left/Right

Combination View (3 groups):

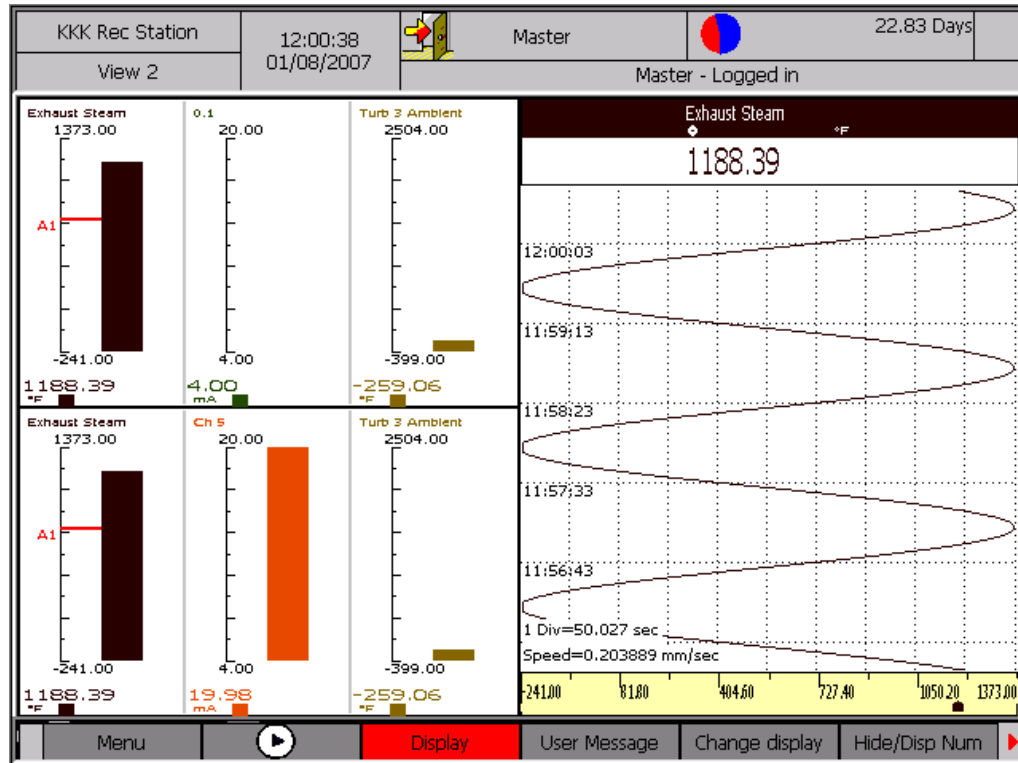

Figure 5. 7: Combination View – 3 Groups

Combination View (2 Groups Top/Bottom):

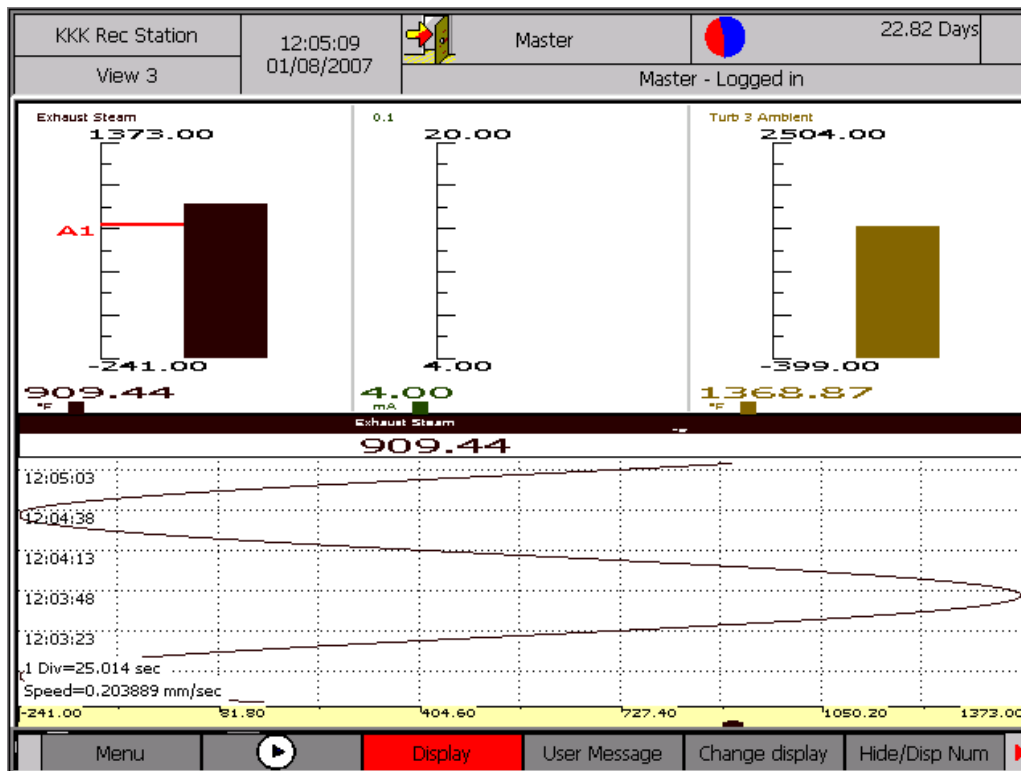

Figure 5. 8: Combination View – 2 Groups Top/Bottom

Combination View (4 groups):

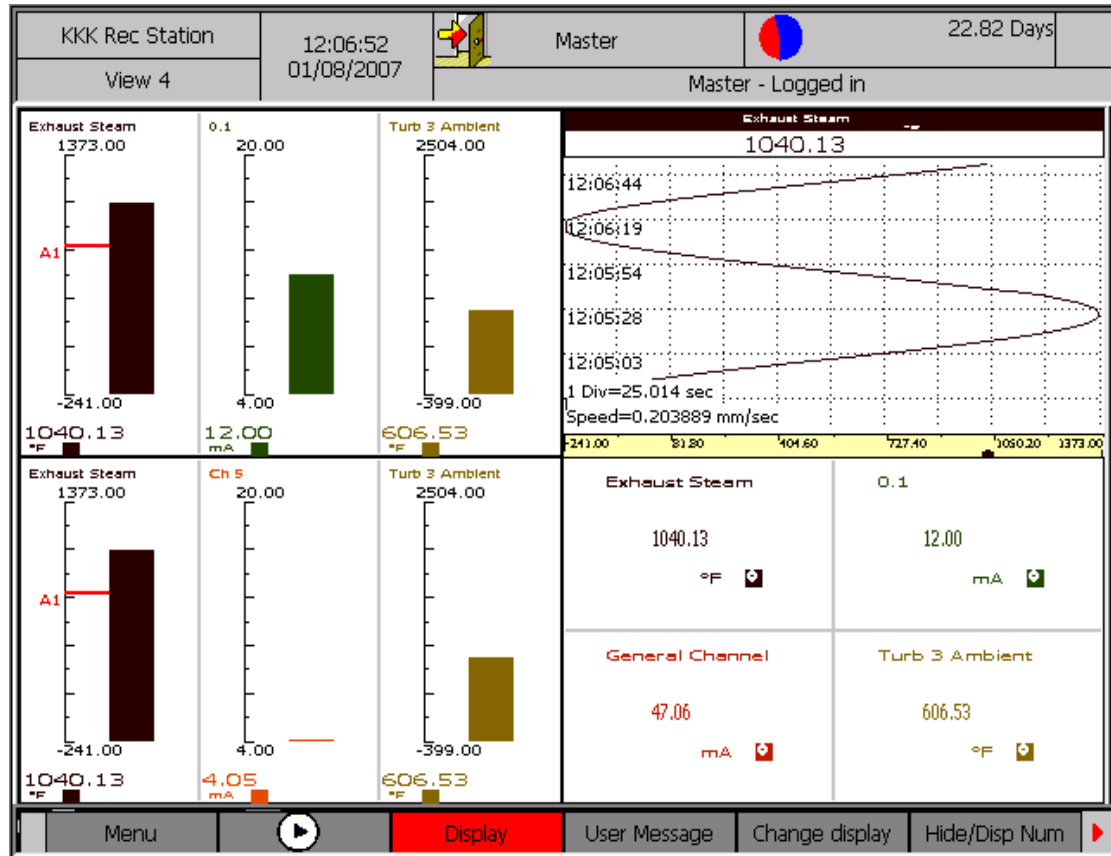

Figure 5. 9: Combination View – 4 Groups

### 5.3 Measurement Value Overview

This overview shows present value of all the configured channels in numeric form

Select 'Display' → 'Measurement Value Overview'. Measurement Value Overview will be displayed in the status bar. After selecting, press the knob to see the Measurement Value Overview. Rotate the knob in clockwise direction and press 'Next' to see next channels. Rotate the knob and press 'Prev' to see previous channels.



Figure 5. 10: Measurement value overview

### 5.4 Message Overview

Message Overview gives a complete survey of the recorder. By selecting 'Message Overview' option from the 'Display' menu, a submenu is displayed, which shows different types of logs available with recorder as shown in figure 5.11 and discussed below.

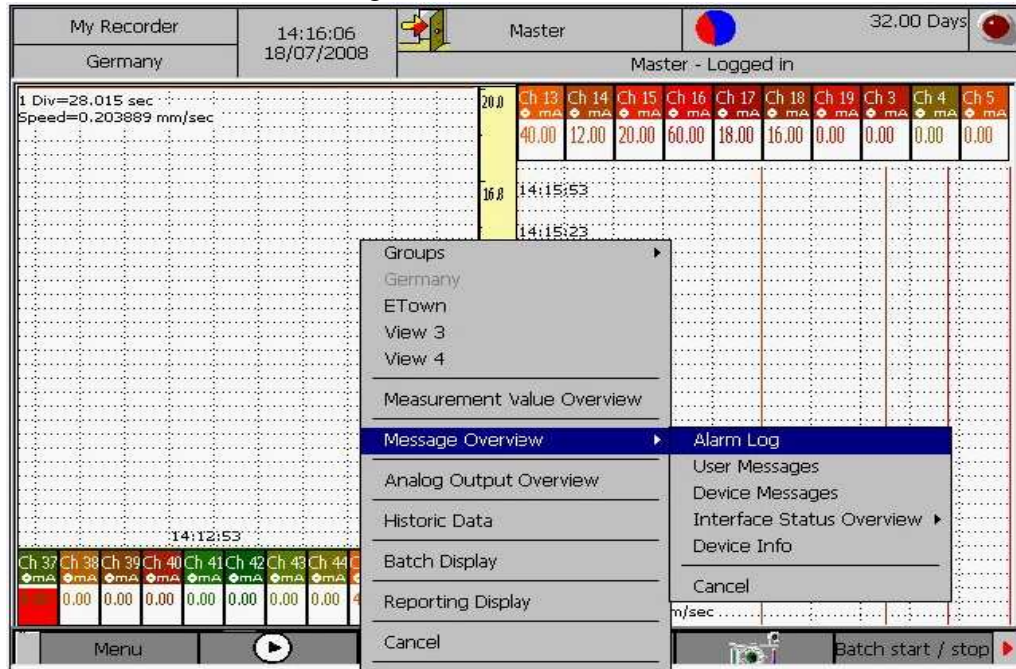

Figure 5. 11: Message Overview

Procedure:

1. Select Display → Message Overview → (Alarm Log/ User messages / Device messages / Device info)
2. After selecting press the knob to enter into the selected item.
3. Same procedure is followed for 'MODBUS status', 'FTP status' and 'Email status' which are under 'Interface status overview'.

### 5.4.1 Alarm Log

Alarm log maintains a record of the last 100 alarm events (alarm start and stop as separate events). Alarm log provides the following information: *Channel*: The channel name, for which the alarm started/stopped. *Alarm Type*: High Alarm, Low Alarm or Gradient Alarm. *Alarm Time*: Start/Stop time of the alarm *Status*: It tells if this log entry is corresponding to start of an alarm or stop of an alarm. *Alarm description*: If some alarm description was provided while configuring that particular alarm, it is shown in a box at the bottom of the dialog, for the alarm selected in the list of log entries. Press *OK* to close the Alarm Log dialog.

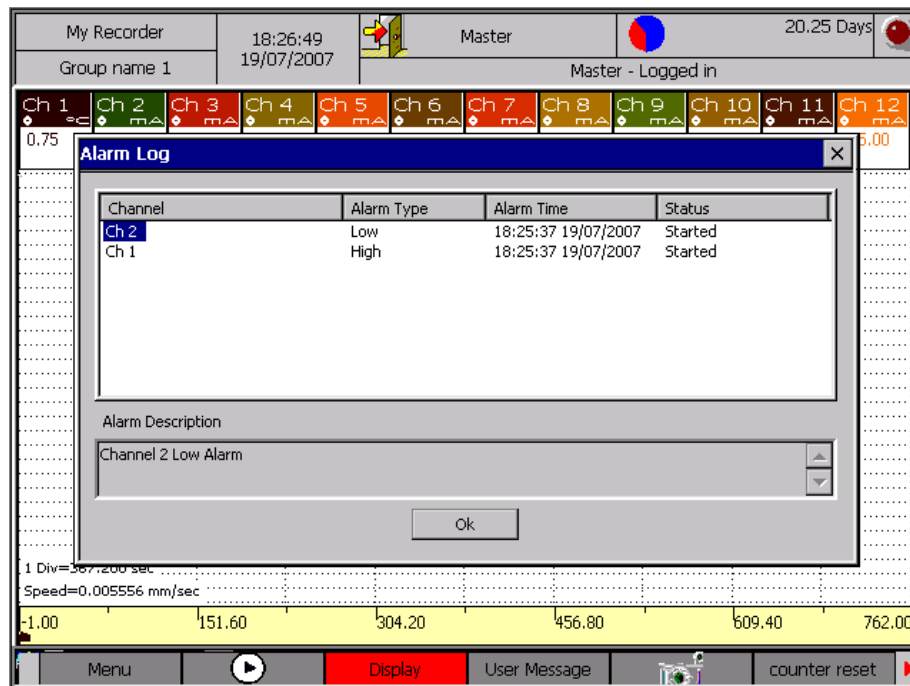

Figure 5. 12: Alarm Log

Memory Alarms are also shown in the same alarm log list.

## 5.4.2 User Messages

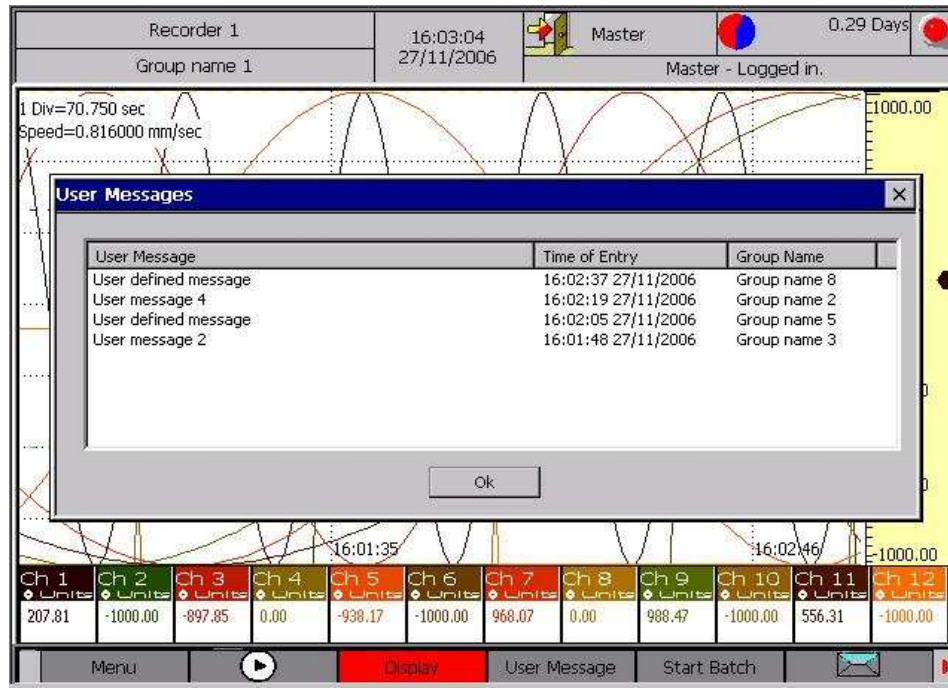

Figure 5. 13: User Message Log

The user message log provides information such as the user messages that have been set, the time at which it was set and the groups with which the messages were associated. The most recent entries into the log file will be displayed on the top of the list. The oldest entry will be the one displayed at the end of the list. The user message log shall have up to a 100 entries. After viewing the entries click on 'OK' button to close the window

## 5.4.3 Device Messages

The overview of the device messages shall show all relevant status information of the hardware along with date and time stamp, which are as follows:

- Recorder power on
- Recording start / stop
- Status of input channels (hardware change)



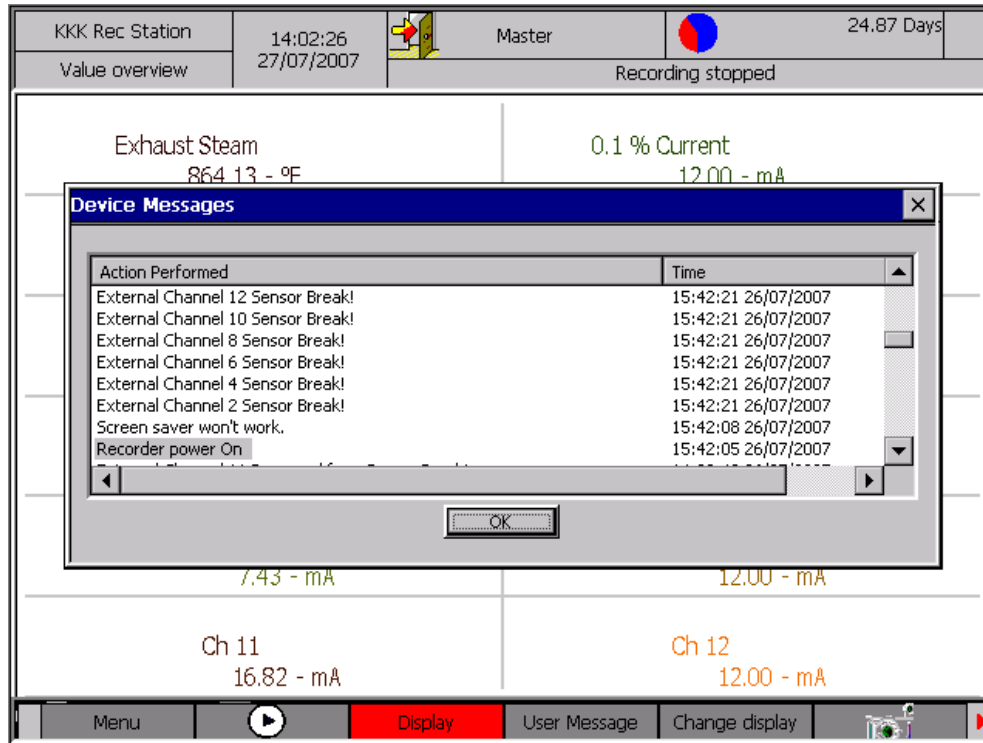

Figure 5. 14: Device Message Log

### 5.4.4 Interface Status Overview

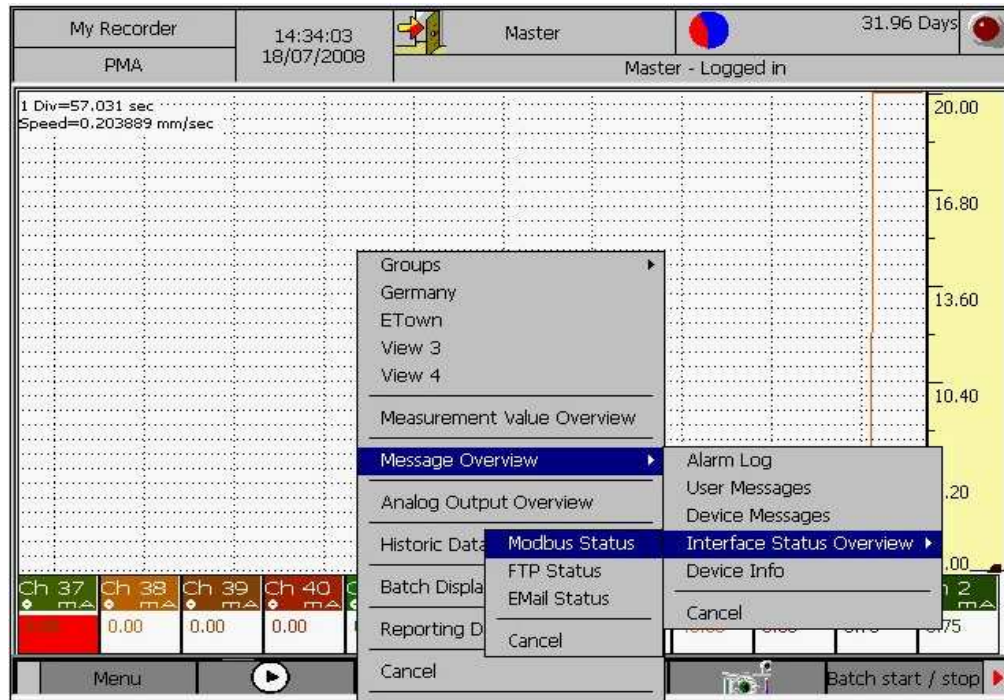

Figure 5. 15: Interface Status Overview Menu

### 5.4.4.1 MODBUS Status

MODBUS Status Log dialog shows last 100 logs for status of each of the available On-Board channels and External channels (refer figure 5.16).

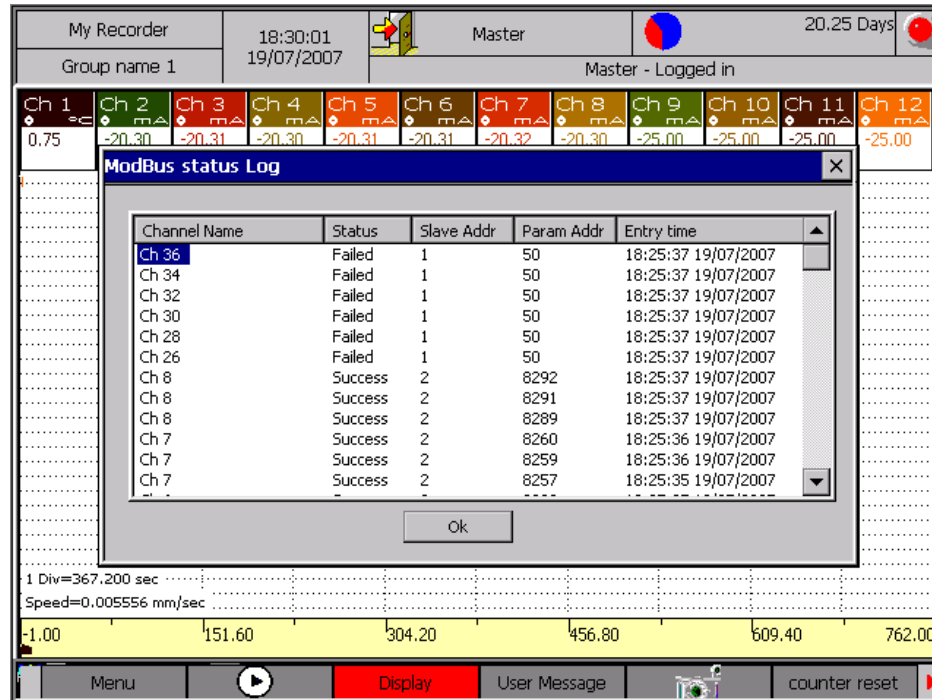

Figure 5. 16: MODBUS Status

First column shows *Channel Name*. Second column shows *Status* of the corresponding channel, i.e. *Failed* if communication with corresponding slave failed, and *Success* if communication with corresponding slave is successful. Third column shows the *Slave Address* of the corresponding channel. Fourth column shows *Parameter Address* (register address) of the process value variable of the corresponding channel. Fifth column provides the *Entry time* of log for the corresponding channel. Logs are generated as soon as a communication event (communication breakup or recovery) occurs.

#### Reading Modbus Logs:

Modbus Logs report status of all the available On-Board and external channels.

When ever recorder starts or configurations (Modbus Settings, Channel Configuration, Temperature, Alarm Relays, Timer, Group configuration or witching between normal or simulation mode ) are changed, all channels are reset and re-configured, and subsequently LOGS are generated reporting their status just after configurations.

#### On-Board Channels (Analog and Digital Input channels):

When On-Board channels are reset, three log entries per channel each representing status of configuring Input Range Type, Range Max. and Range Min. with the associated input card are generated respectively.

For all channels of Temperature type (like the TC Type K) two logs per channel are generated, each representing the status of parameters (Input Range Type and Temperature type respectively) configured.

Each LOG entry mentions the register address and slave address where the configuration parameter WRITE was attempted.

Subsequently, if any On-Board channel fails to communicate/fetch data for consecutive right attempts, a failure LOG is generated for that particular channel along with the slave and register address from where the process value READ was attempted. A success LOG is generated whenever a read operation succeeds after a failure state of the channel.

External RTU Channels:

When External RTU Channels are reset, an initial success or failure log is generated along with the slave and register address that was attempted to be read.

Subsequently, a failure LOG is generated whenever 8 consecutive reads fail and a success LOG is generated whenever a read succeeds after a failure state of the channel.

External TCP Channels:

When External TCP Channels are reset, TCP sockets are allocated to each of these channels. If a socket allocation fails, a failure LOG stating fail to create socket is generated. However there is no success log for this step. If socket creation is successful, then an initial success or failure log is generated along with the slave and register address that was attempted to be connected and read.

Subsequently, a failure LOG is generated whenever 8 consecutive reads fail and a success LOG is generated whenever a read succeeds after a failure state of the channel.

#### **5.4.4.2 FTP Status**

The FTP Status displays the following:

- Time at which the FTP was done.
- Status indicating success or failure.
- Error code and its corresponding description.
- Files that have been transferred.
- FTP Server address to which the files were uploaded.

To view the error code description

- Rotate the knob until the list is highlighted. Press the knob to enter the list.
- The error code description is displayed in a box in the bottom for the item selected in the Logs list above.

Click on 'OK' button to close the window.

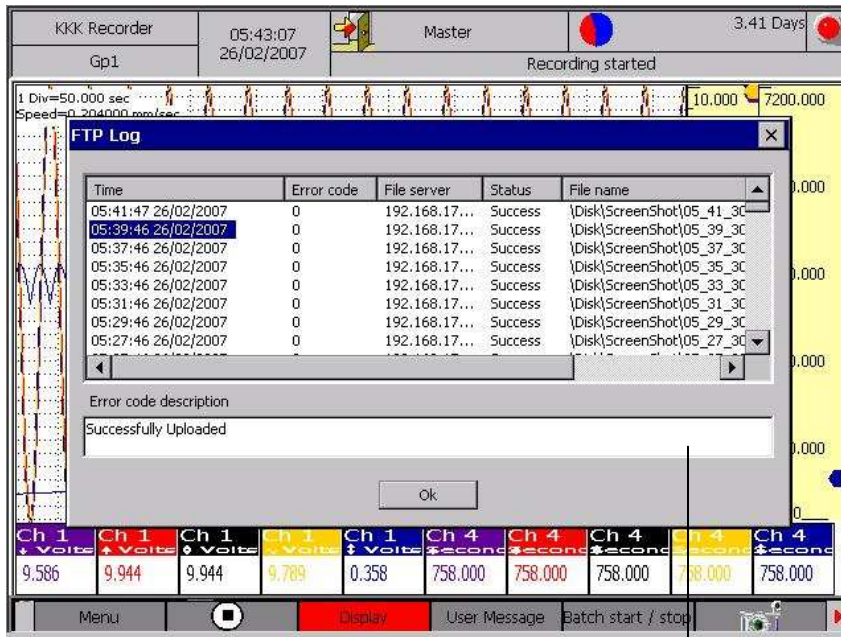

Figure 5. 17:FTP Status

Error code description

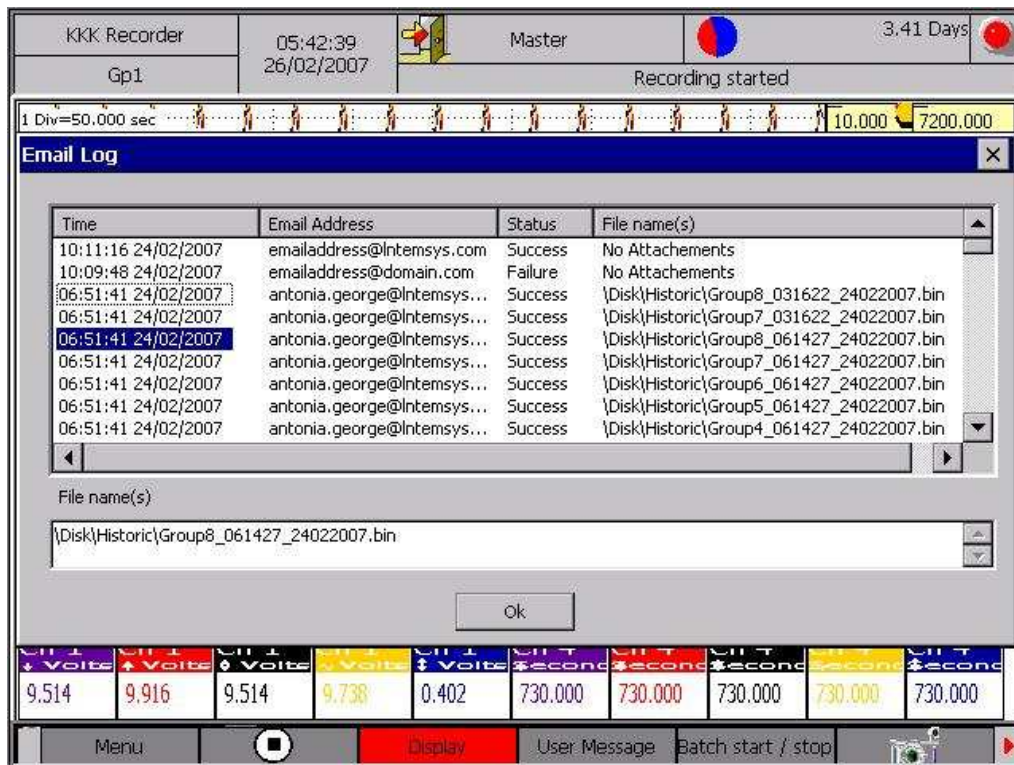

Figure 5. 18: Email Status

### 5.4.4.3 Email Status

The Email Status displays the following information:

- Time at which the Email was attempted.
- Status indicating success or failure.
- Files that have been sent as attachments.
- Email addresses of the recipients.

Procedure to check Email Status is similar to that for FTP Status. Refer Figure 5.18 shown above.

#### *EMAIL LOG GENERATION:*

EMAIL Logs are generated for each EMAIL transfer, whether done from TEST BUTTON, USER KEY or configured schedule. Additionally, there is one entry per file transfer attempt per address.

If recorder fails to connect to SMTP Server, there is a single log entry irrespective of the number of addressees and files. Log description indicates failure in connecting to SMTP server in such a case.

### 5.4.5 Device Information

The Device Information displays the following:-

- Recorder name
- Description
- Duration for which recording has been done.
- Duration for which display has been done.
- CF Card Memory size in MB
- Channel information such as the number of On-Board Analog Input channels, External channels, Calculation channels, On-Board Digital Input Channels, Analog Output channels and Relays.
- Languages supported by the recorder
- Features available such as USB, Software Up gradation, Email and FTP etc. Refer Figure 5.19 below for details.
- Product details, i.e. Software Version, IP address and MAC Address of the device

To close this window, click on the 'OK' button.

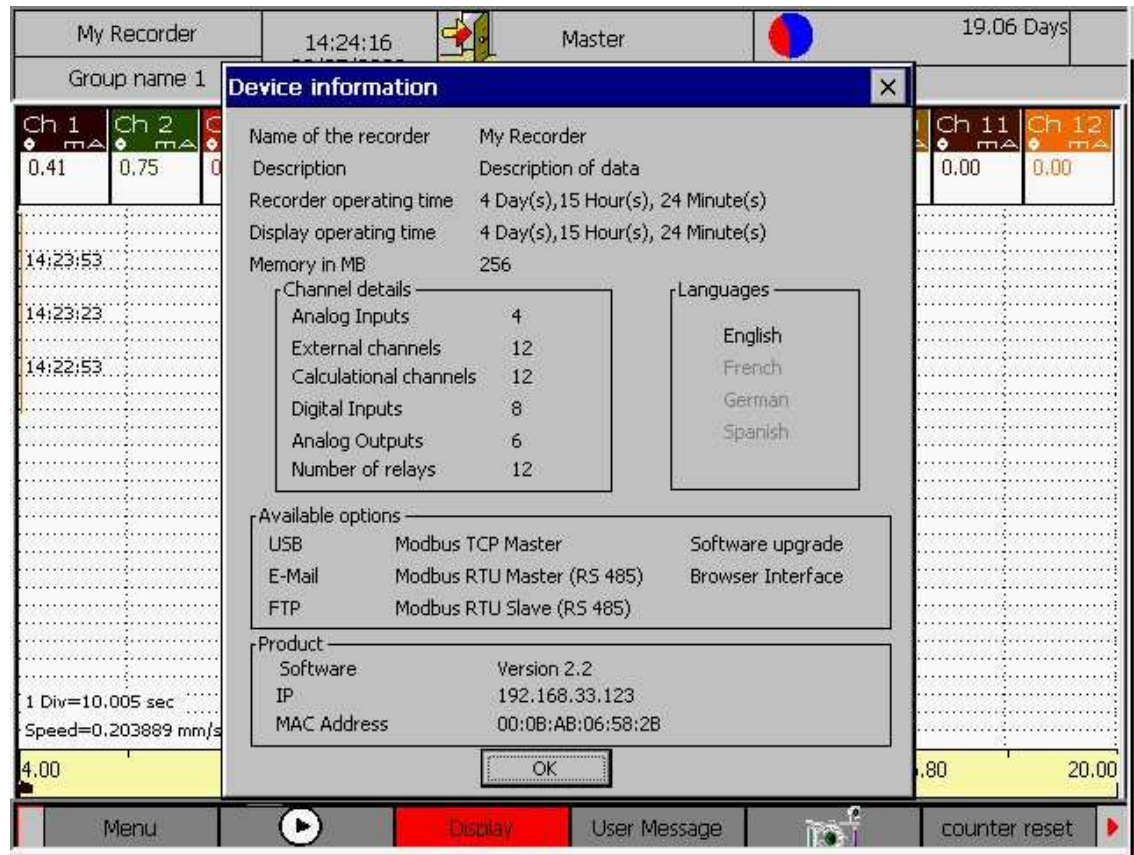

Figure 5. 19: Device Information

## 5.5 Analog Output Overview

By selecting Display button in the short cut bar the screen will be displayed as Fig 5.20.

If Analog card is available in the recorder then Analog Output Overview is enabled otherwise it's disabled with Gray color.

Analog Output overview is used to view the Source value and Scaling value which is configured by the Analog Output Configuration dialog. And also used to forcing the Analog Output channel value.

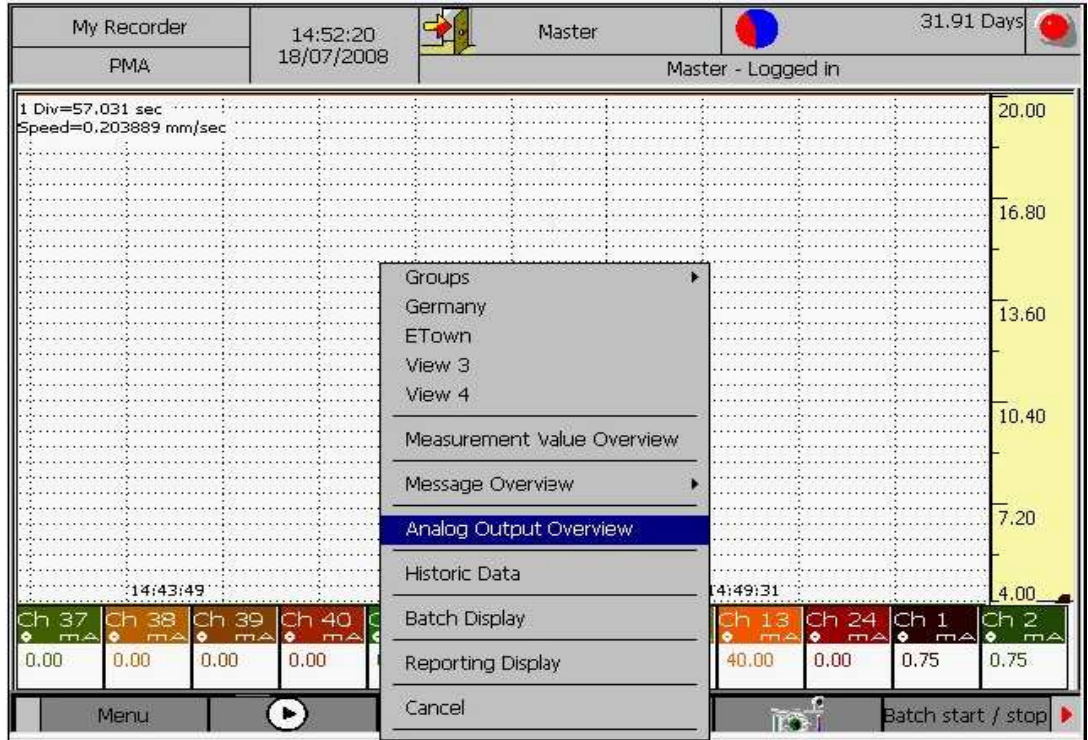

Fig 5.20 Analog Output Overview

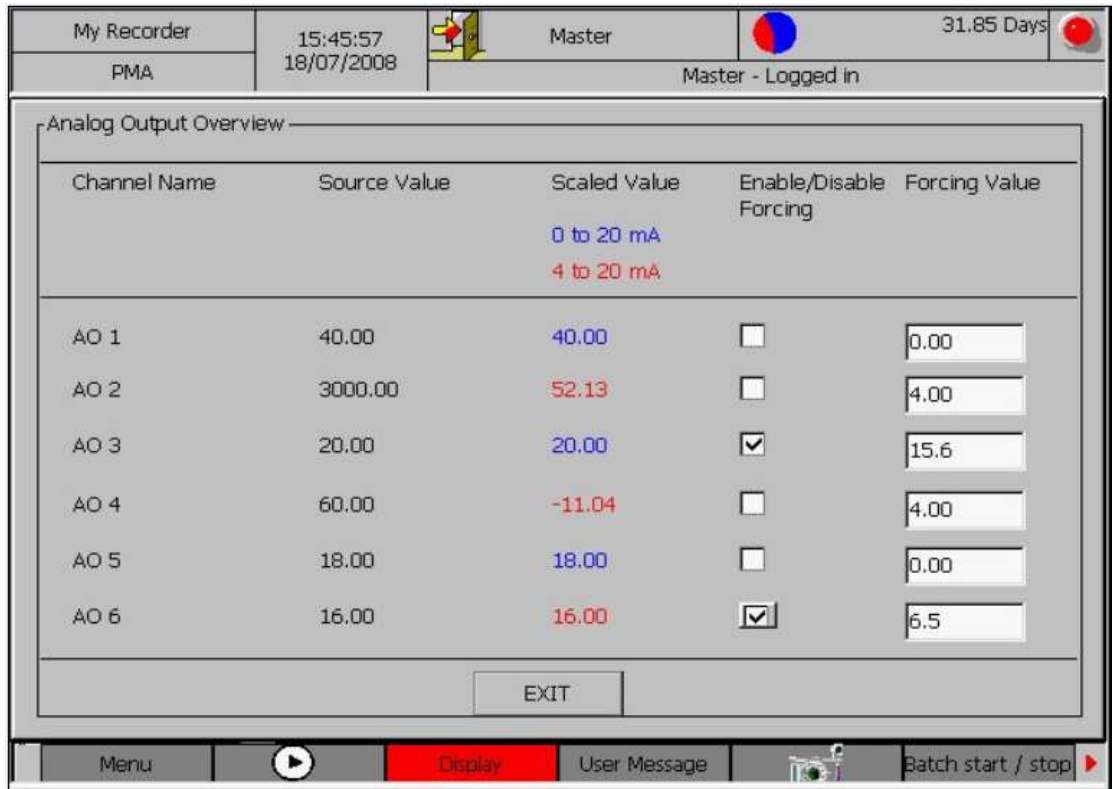

Fig 5.21 Analog Output Overview page

**Channel Name:** It's consists of channel's name which is configured by the Analog Output Configuration dialog.

**Source value:** This column display source channel values at an interval of every one second.

**Scaled value:** This column display scaled channel value at an interval of every one second. The Scaled value displayed in 2 colors, if AO channel's Signal type is 0 to 20 mA then value will be displayed in Blue color otherwise it's in Red color (For 4 to 20 mA Signal type).

Ex: Input value to the AO 2 is 3000 and Scaling factors are input minimum is 4, input max is 1000, output min is 4 and output max is 20 then scaled output is 52.13

### **Forcing Output:**

As soon as the Analog Output overview dialog comes up, the focus is on the first Enable/Disable Forcing check box. By rotating the knob, in clockwise or anti clockwise, the control goes through the different Edit boxes and check boxes. Once user press the check box AO channel output is set with the corresponding value which is set by the user in the Edit box.

The edit box next to the check box is always enabled. This edit box shall allow user to enter data in between 0 to 20 if signal type selected is 0 to 20mA or it's 4 to 20. After enabling the checkbox output will be forced with user data .If it is already enabled enter the data into the Edit box and press Enter which force the value to the corresponding Analog output channel. Forcing shall be stopped after disable the check box or after status page shall be closed.

**Note:** Refresh rate of the page is 1 sec.

## **5.6 Historic Data**

Historic Data is used for viewing historic group files in the memory.

Procedure:

Selecting the "Historic Data" option from the Display menu opens a dialog window as shown below in figure 5.20. The dialog displays list of all historic group files present in the recorder memory along with their start and stop times.

Select any one file from the list box and press '*Display Hist*' button. The '*Select values to plot*' dialog is displayed (please refer figure 5.22 below). Channels which are recorded in the selected file along with the values (minimum, maximum, mean, present and peak) recorded for each channel are displayed here.



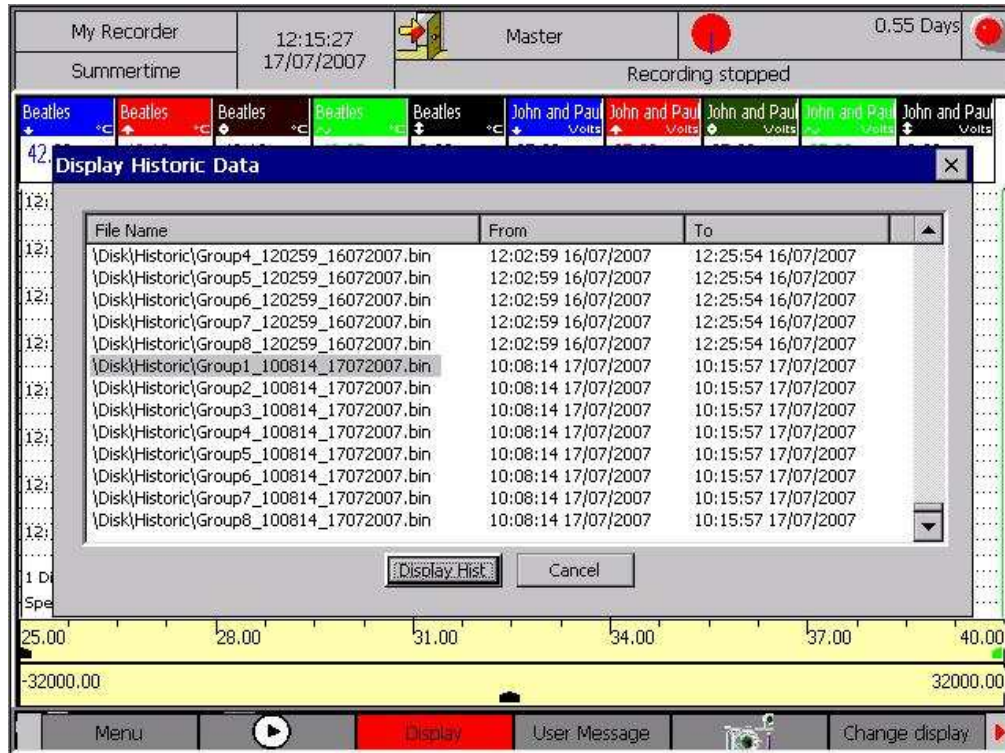

Figure 5. 22: Historic Data

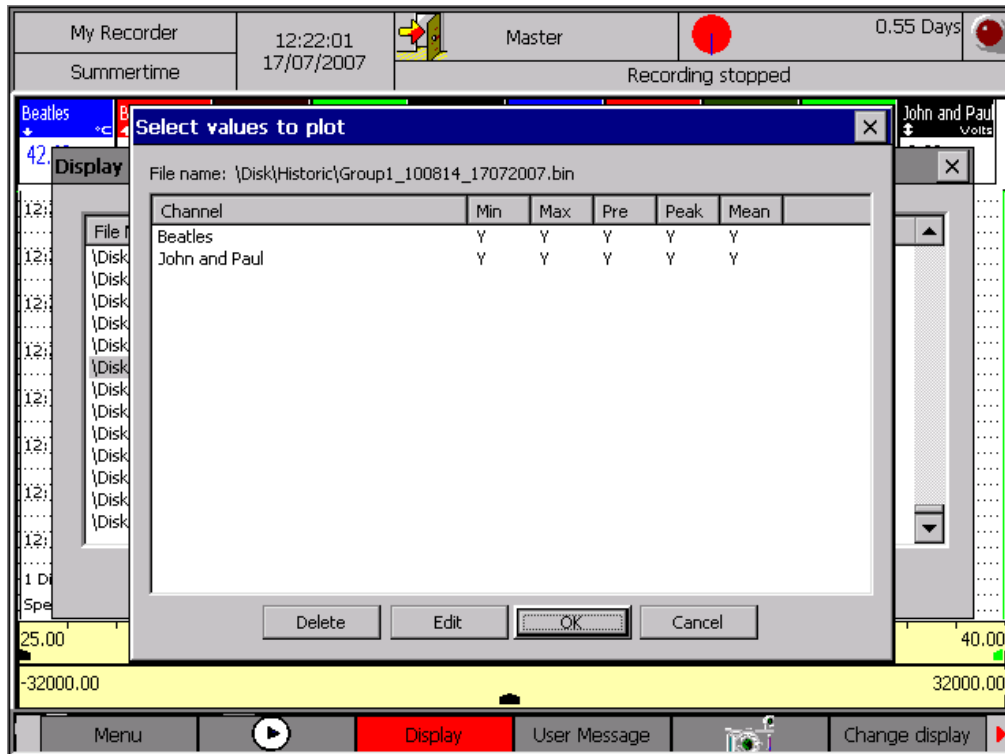

Figure 5. 203: Select values to plot.

The above dialog (as shown in figure 5.23 above) will allow user to select a maximum of 12 channel values to plot in the historic mode. If the recorded channel values are more than 12, then you have to de-select few of the channel values to make it less or equal to 12. The values (Min, Max, Mean, Peak and Present) of each channel will be enabled only if it has been selected for recording, in the channel configuration. To remove the channel, select the channel name from the list, and press the delete button. The corresponding channel number will be deleted from the above list.

To edit (deselect values) any of the available channels, select the channel's name from the list and press *Edit Channel* button. The below dialog box will be displayed, showing the corresponding channel values which are available for the display. To deselect or to select (which has been previously deselected) rotate the knob, to move the focus on the particular value and press the knob. Press OK button to save the changes made or Cancel button to discard the changes.

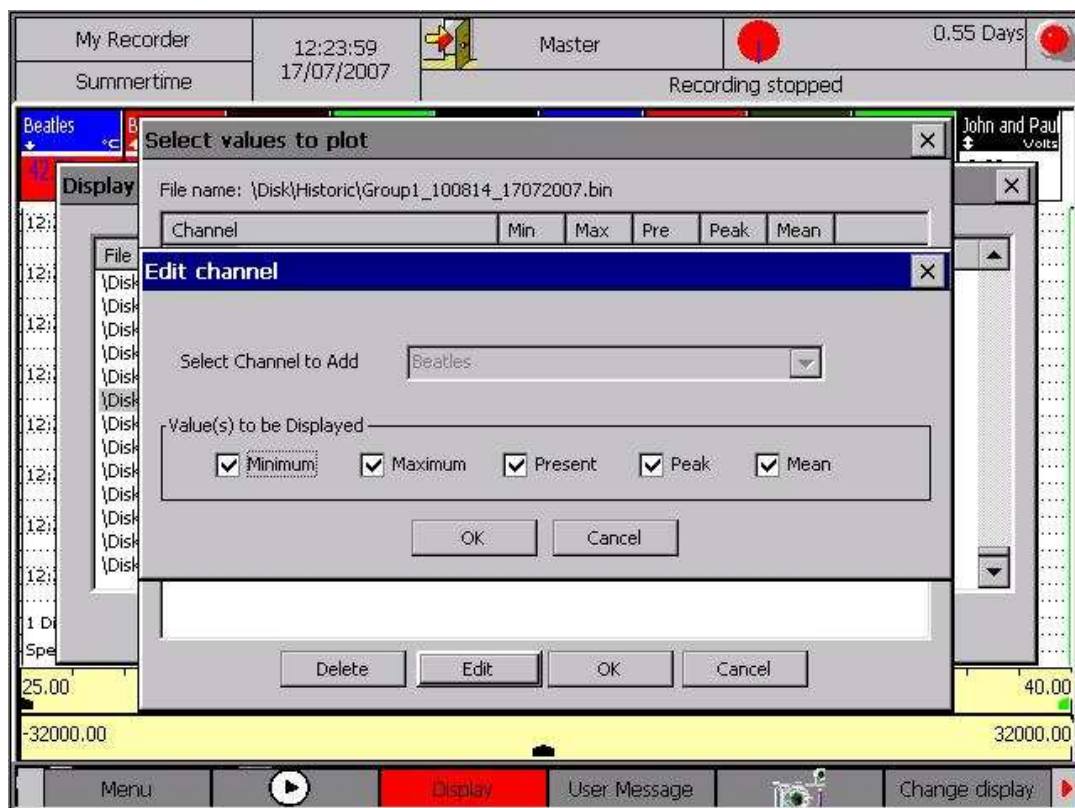

Figure 5.24: Select values to plot.

After selecting channels values (less than or equal to 12), the you can view the corresponding Historic data in the graph area, by pressing 'OK' button of 'Select values to plot' dialog. Historic Data window has three main parts:

- In the top most portion of the window, group details (group name, recording start & stop time) of the corresponding historic file are shown.
- In the Overview section (middle portion), entire channel data is stored in the file is plotted, along with an overview cursor (by default, always in middle of the screen).

- In *Zoom* section, the enlarged view (by default 1X) of the file's content are displayed, based on the cursor's position in the over view. This section also has a cursor which is used for obtaining the numeric values of the displayed channel values. Based on this cursor's position the numeric value of the channels will be displayed in numeric section of the screen.

Using *Zoom In/Out* buttons, you can view an enlarged or compressed view of historic data. *Prev* and *Next* buttons are used for shifting the cursor in focus in left or right direction respectively. Focus can be shifted from *Overview Plot* to *Zoom View Plot* and vice versa using the *Zoom View* and *Overview* buttons respectively.

The functionalities of buttons available in short cut bar are as follows.

- *Zoom In*: Is used to expand the graphs, which will be shown in the zoom portion of the screen. Maximum zoom in is 30 x and above which even if you press zoom then no effect on zoomed portion.
- *Zoom Out*: Is used to compress the graph, which is shown in the zoom portion of the screen. Maximum zoom out is 30x .Graph can't be compressed more than that.
- *Overview/Zoom View*: By default *Overview* button will be displayed on the short cut bar. Rotate the knob to shift the focus to this button and press the knob. It will rename itself as 'Zoom view' if its current previous name was 'Overview' and vice-versa. If *Overview* button is been displayed in the shortcut bar, then focus is on the *Zoom* portion of the screen, *Prev* & *Next* button will move the zoom cursor either left or right. If *Zoom view* button is being displayed, then the focus is on overview portion of the screen, pressing *Prev* or *Next* button will shift overview cursor either left or right.
- *Prev*: used for moving overview or zoom cursor in left direction.
- *Next*: used for moving overview or zoom cursor in right direction.
- *Exit*: Exits from historic display to previously showed display. (Previous display may be any group, combination view, live batch).

To view a different portion of the file, select the overview button (after selecting it will be renamed as *Zoom view*), then using *Next* & *Prev* button move the overview cursor in the right or left direction. After shifting the overview cursor, select *Zoom view* button (after selecting it will be renamed as *Overview*). Based on the new overview cursor position, zoom portion is plotted using the historic data stored in that specific portion of the file.

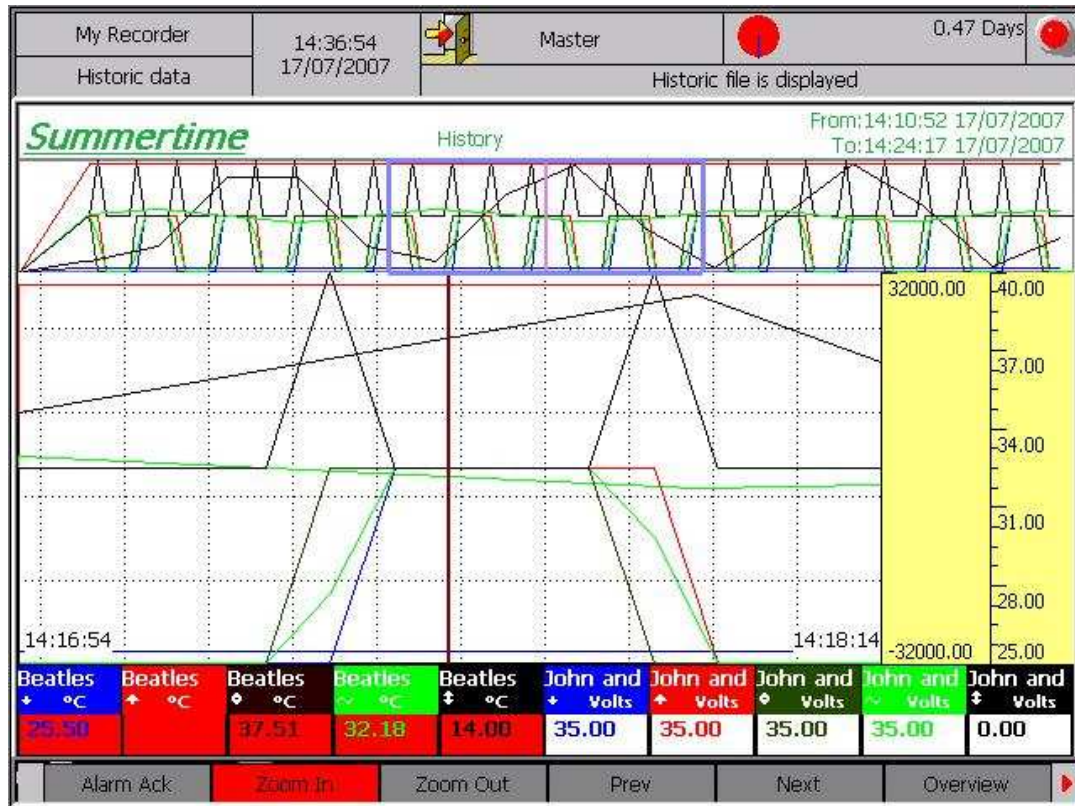

Figure 5. 215: Historic Data Display

## 5.7 Batch Display

Batch is a group of channels (Maximum 44 channels may be there in a batch). Batch can be live or historic. You may view any 12 channels from a batch.

Select Display->Batch Display.

### *Live Batch:*

Each batch which is enabled in batch configuration is considered as Live Batch irrespective of whether recording is 'On' or 'Off'. Rotate knob and go to Display. Press knob, The Display menu will pop up.

Rotate the knob in clockwise direction and select Batch Display. Press the knob. A dialog box will pop up as shown in figure 5.26 below, to make selection for Live or Historic batch. Initially focus is on Live and all the enabled batches will be listed in the list. Rotate the knob to scroll through list and press the knob to select a batch. Rotate the knob until it comes to 'Ok' button. To proceed with batch display press 'Ok' else press 'Cancel'.

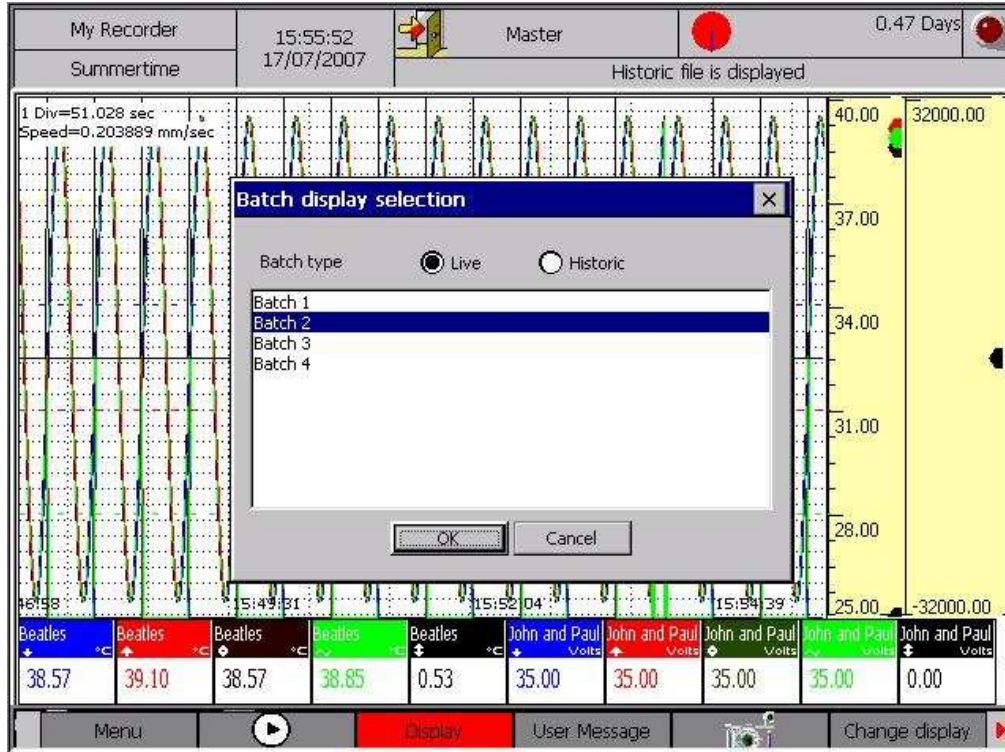

Figure 5. 226: Historic Data Display

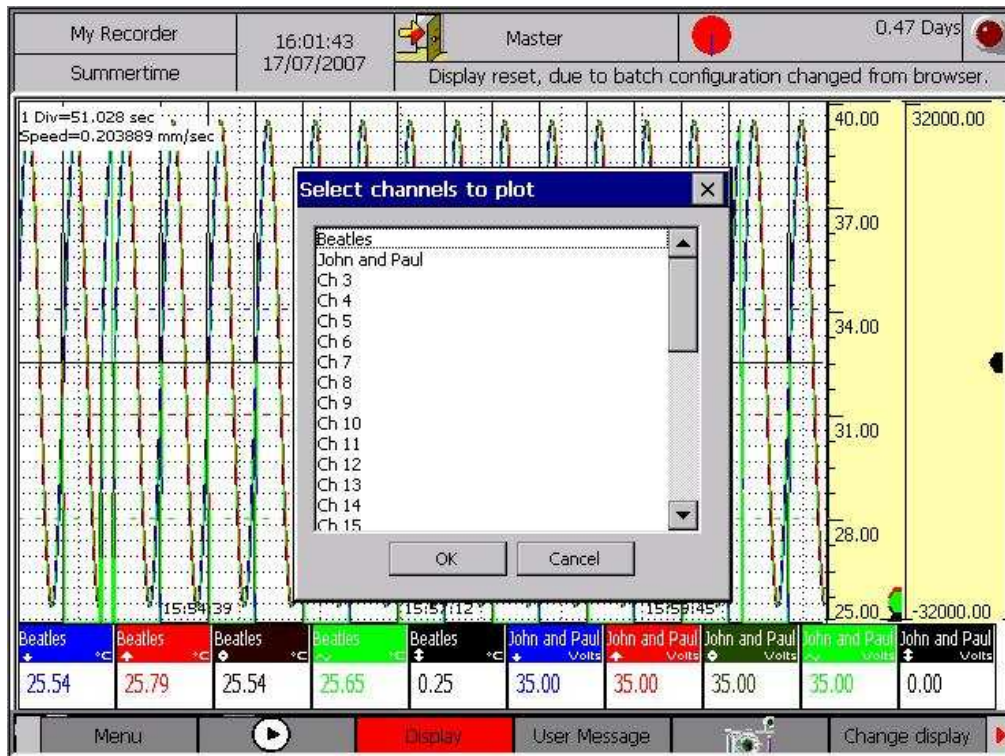

Figure 5. 27: Historic Data Display

After pressing 'Ok' one dialog box 'to select channels to plot' will pop up. Rotate the knob and press it to select the channels from the list. The list supports multiple selections, so more than one channel may be selected at a time. Focus will be on selected channels. Rotate knob. Rotate the knob until 'Ok' button is in focus; press it to display the batch.

After pressing 'Ok', live batch will be displayed as shown below. It's the same as horizontal trend display of groups. Only difference is that for a batch, batch information (batch number, status and batch description) is displayed. Time required to shift 1 division for the graph, is displayed at the top side of screen. This time depends upon vertical grid spacing and display speed of batch. Only present data is displayed in live batch.

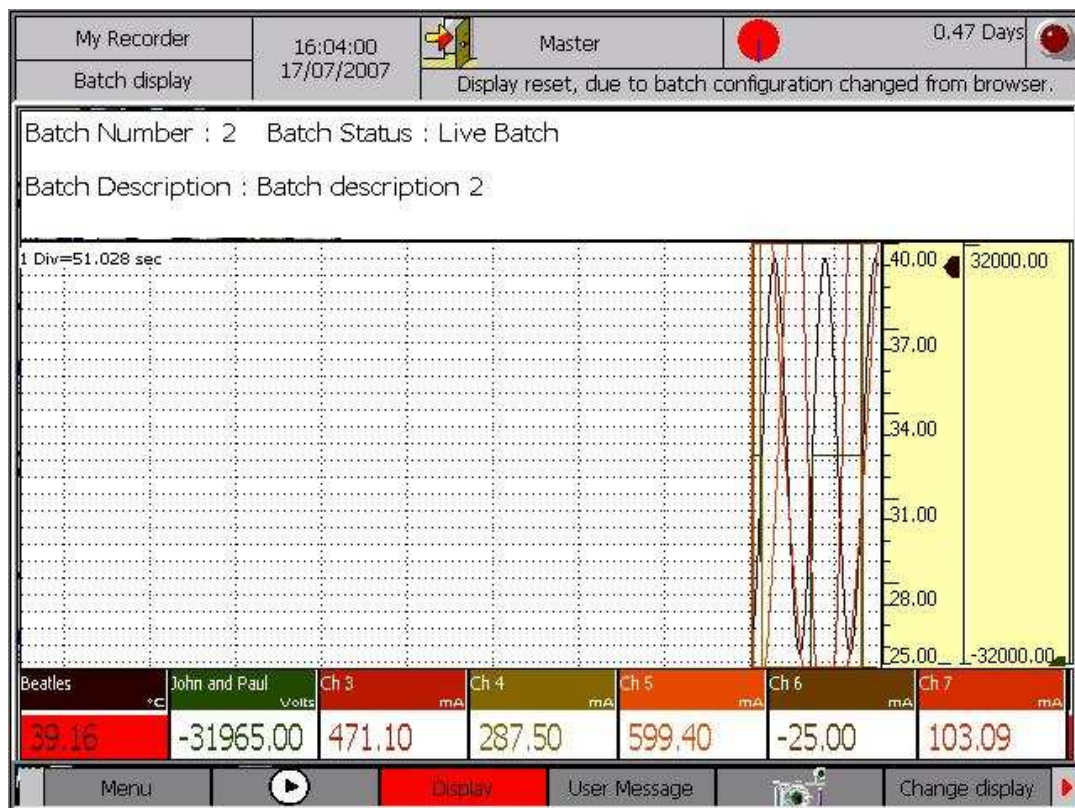

Figure 5. 238: Historic Data Display

#### *Historic Batch:*

Historic Batch is used for viewing the recorded batch files, which reside in CF card.

#### *Procedure:*

Select the 'Batch Display' option from the Display menu. 'Batch Display Selection' dialog (please refer the below figure 5.29) will be displayed with 'Live' radio button enabled by default. Instead rotate the knob and select 'Historic' option. The list of recorded batch files will be displayed in the

list box, with default focus on the first file name in the list. To select a file, turn the knob to shift the focus to the required file and then press the knob.

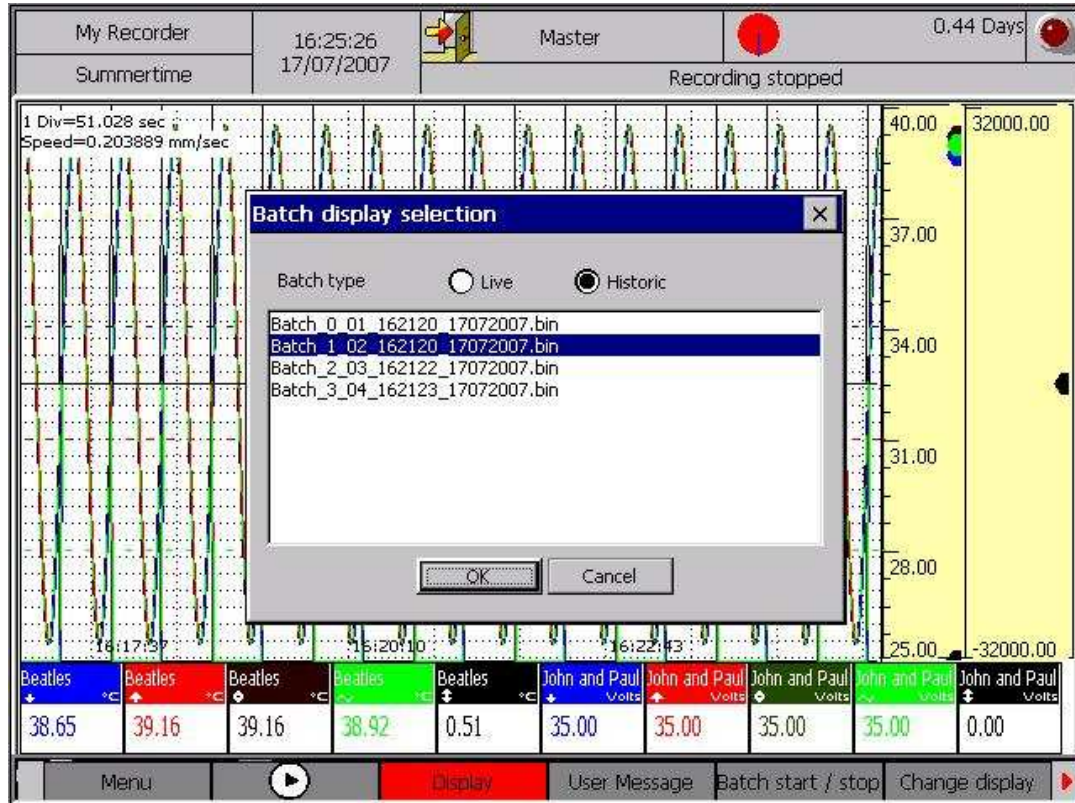

Figure 5. 249: Batch Display Selection (Historic)

Select 'Ok' button to continue, or 'Cancel' to terminate the mode. Pressing 'Ok' button will display 'Select any 12 channels to plot' dialog, which will display the list of the channels recorded in the file (default focus on the first name in the list). If the file has more than 12 channels, you have to select 12 or less channels from the list. This dialog will allow you to select a maximum of 12 channels to view in the historic mode. You may select multiple channels from the list. To select a channel, turn the knob to shift the focus to the channel name to be selected, and press it. The selected channel name will be displayed with the blue color background. In the historic batch, by default the Present value (among min, max, present, and mean, peak) of the selected channels is displayed.

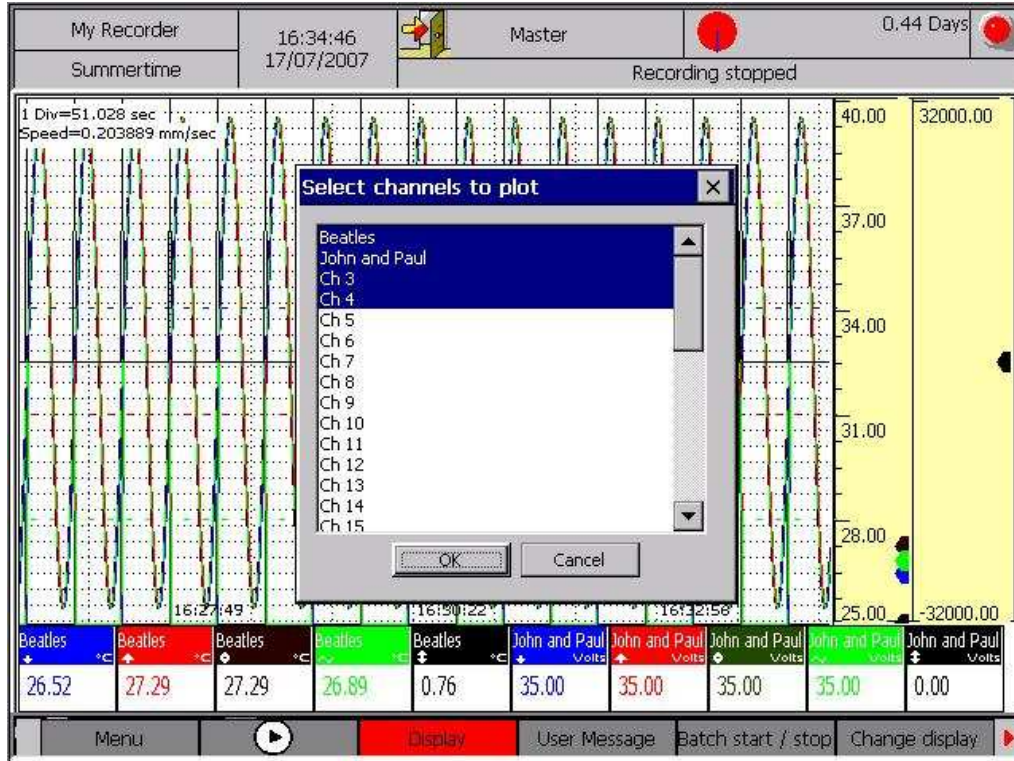

Figure 5.30: Select any 12 channels to plot

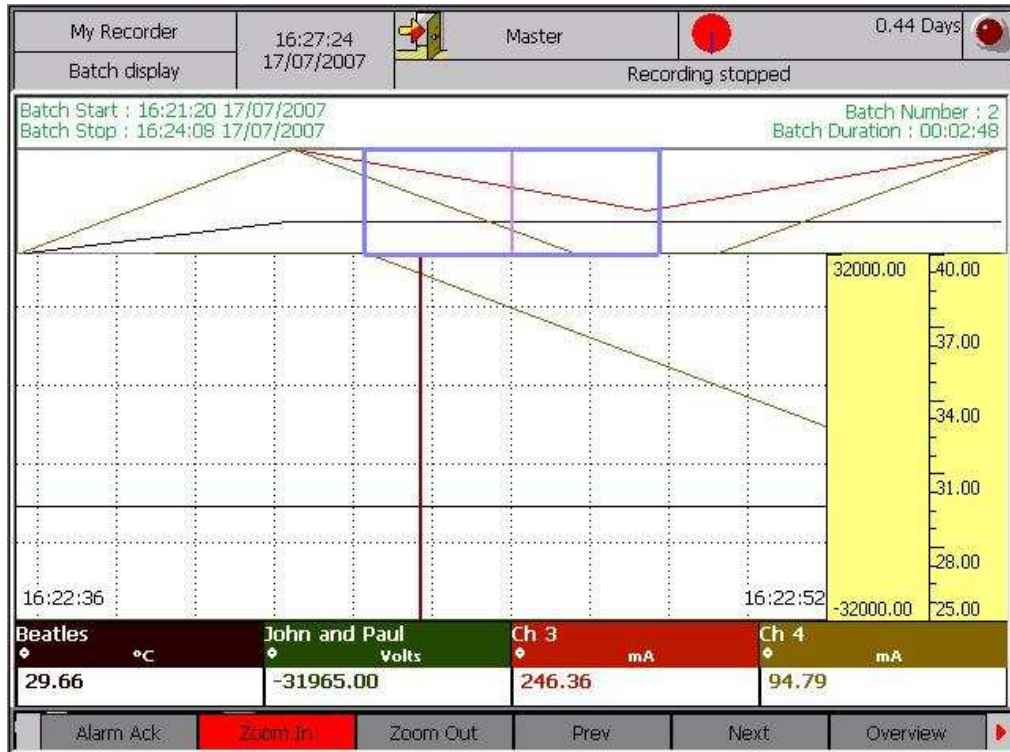

Figure 5.31: Batch Display



Select 'Ok' button to display channel data in the file. In top portion of the window the batch details such as batch start & stop time, batch number and batch duration will be displayed. Rest of the functionality is similar has historic data (please refer 5.5).

## 5.8 Reporting Display

This option will display Reports

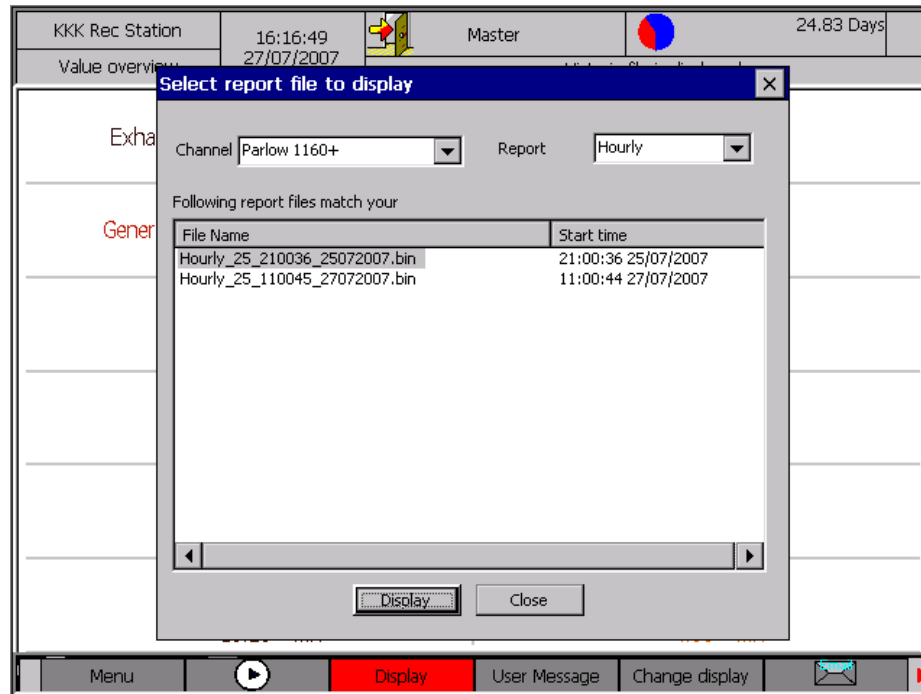

Figure 5. 252: Selection of Report to Display

Procedure:

1. Select Display → Reporting display and press the knob option
2. Then go to selection of channel by pressing the knob and then rotate it to select the channel then press again the knob to come out of that list
3. Then rotate the knob to report field to select the type of the report and follow the same procedure as above to select the type
4. The rotate the knob to select the file among the listed files and then press knob
5. Then rotate again to select among display and close and press the knob

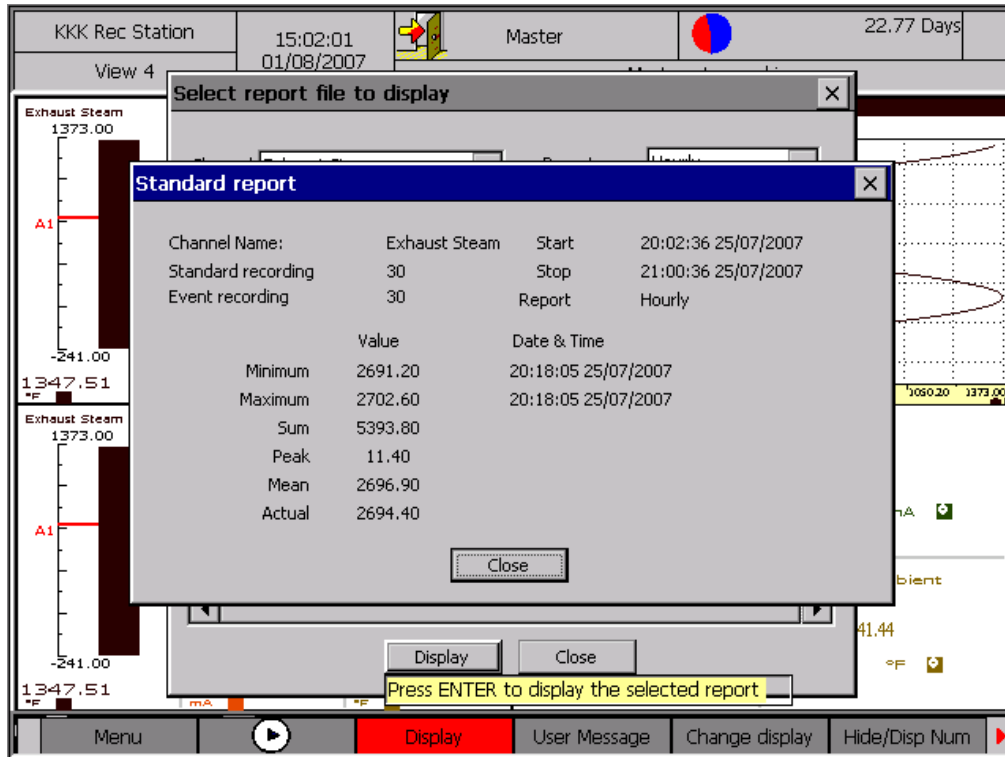

Figure 5. 263: Report Display

## 6 User Message



Figure 6. 1: User Message

You can use this option to enter a user message. The user message can be a predefined user message or a user defined message. If you have selected a predefined message, select the message from the list provided. Then select the group with which the message should be associated and click on the 'OK' button. Every user message has to be associated with a group. The user message entered is then displayed in the user message section of the Top Status Bar. It will also be entered into the user messages log and in the file currently being recorded for the specified group.

To enter the User defined message select the 'User Defined' option. Then enter the message in the 'Set Message' box and select the group associated with the message and then click on the 'OK' button.

## 7 Shortcut Bar

The short cut bar is displayed at the base of the display. You can select the following from the short cut bar.

- Menu
- Recording Start/Stop: When the recording is started all the group files are generated. If the recording is stopped before the first set of data is received, the files will be empty. If a power failure occurs while recording is on and if the files get corrupt, they will be recovered if possible otherwise they will be deleted.  
NOTE: Once the recording is ON, no configuration changes are allowed. As a result any item under *Menu* is not available when recording is in progress.
- Display Menu
- Alarm Acknowledgement
- USB
- User Keys 1 and 2

Of these Alarm Acknowledgement is added to the short cut only when there is an alarm to acknowledge. The USB is also added only when there is a USB storage device attached to the USB port.

### 7.1 Alarm Acknowledgement

If any channel alarm is occurred then the user need to select the alarm acknowledgment option, which will be available in the shortcut bar, and the screen will be displayed as follows.

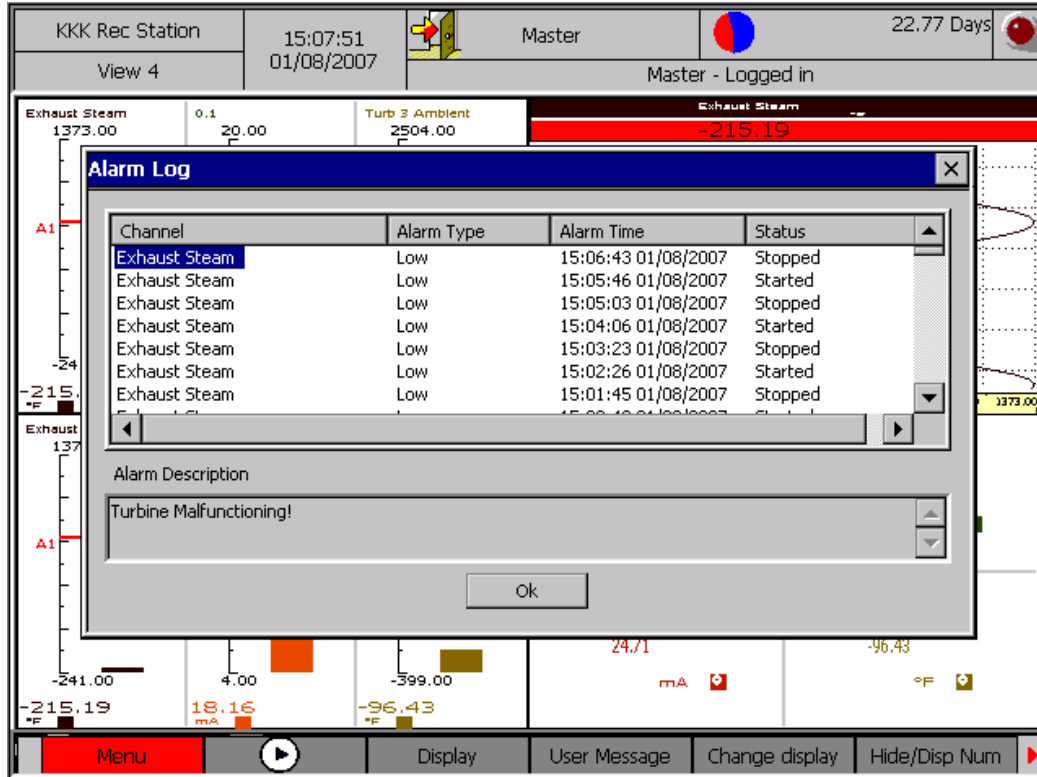

Figure 7. 1: Alarm Acknowledgment

## 7.2 USB

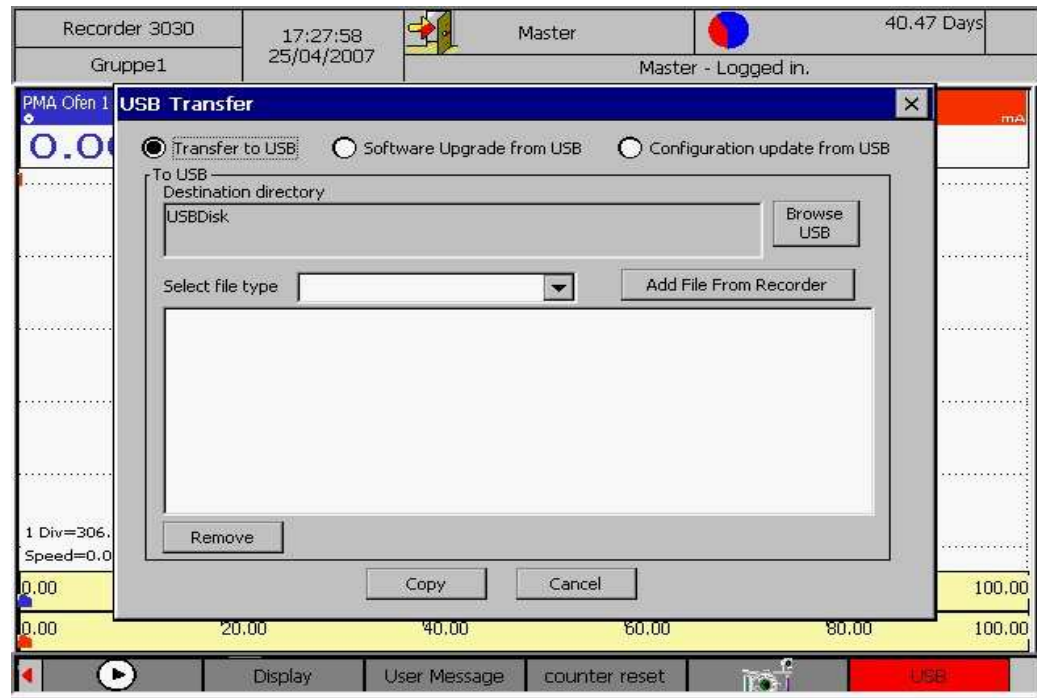

Figure 7. 2: USB Screen

If the user connects the USB storage device to the recorder, then the following dialog box will be displayed and USB option in the shortcut will be added

When user selects “Transfer to USB”. User will be allowed to select files to copy to USB. User is able to transfer the following types of files to USB. Batch files, Historic files, Report files, Screen shot, Startup images, basic configuration file, Off line configuration, File conversion and Java SW.

If user selects “software upgrade from USB” and chooses copy then recorder will searches for the following files in the USB. If files present then it will update the system and restarts the recorder.

App1.exe  
 index.html  
 nk.bin  
 JavaSW.zip  
 FileConversion.exe  
 OfflineConfig.exe

In addition to this if any folder with www is present, then all the files with in the directory will be copied to recorder. It also upgrade “CALIBRATOR.exe” file, if it’s available in the USB storage device.

When user selects “Configuration update from USB” the following screen will be displayed.

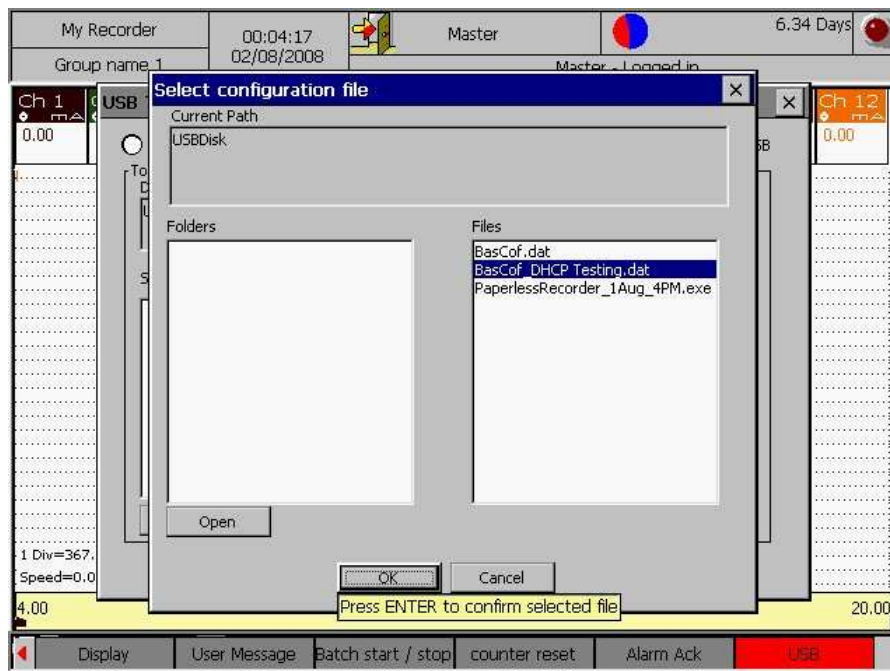

Figure 7. 3: Basic configuration selection dialog.

User will be allowed to select files from USB, after selecting file the file will be validated and copied to recorder and after that recorder will restart with new configuration.

## 8 UserKey 1 and UserKey 2

### 8.1 User Key FTP

When you select FTP option from Short cut bar, the following screen will appear.

Then you can select the type of file to be uploaded. The file type can be any of the following

- Batch Files
- Historic Files
- Report Files
- Screen Shot Files
- Start Up Image Files

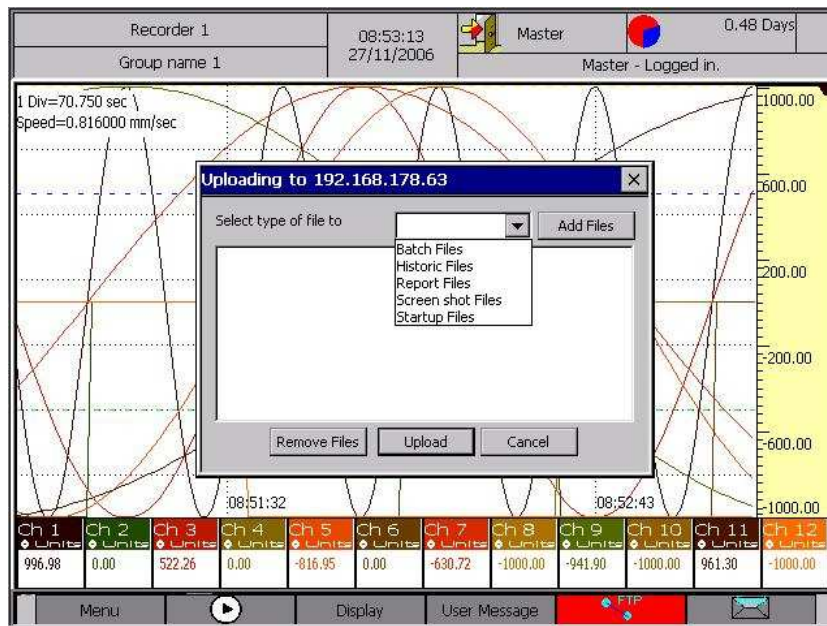

Figure 8. 1: FTP Upload

After you have selected the file type to upload, click on the 'Add Files' button and all the files of that type will be listed in another window as shown in Fig 8.2. In the picture files of type Batch is listed. You can select multiple files from the list. Once the required files have been selected, click on the 'Open' button.

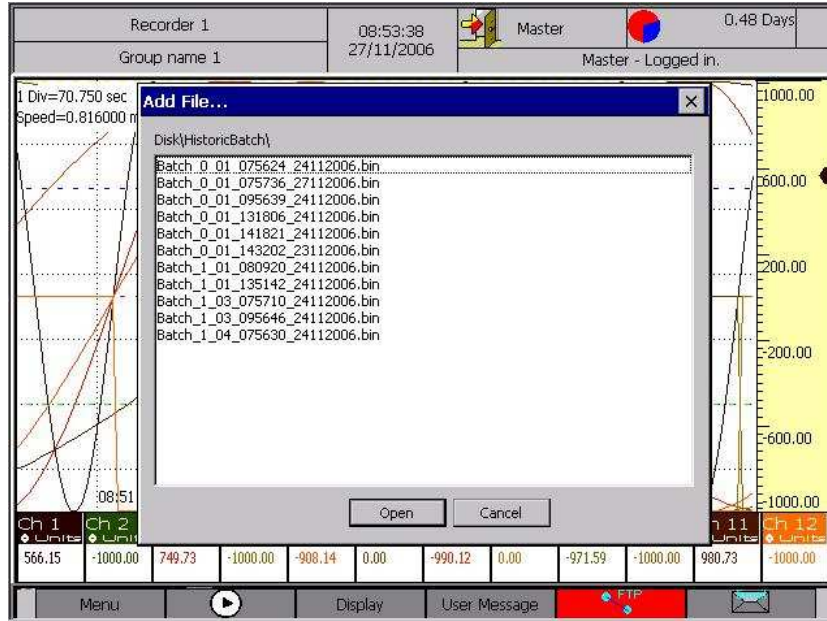

Figure 8. 2: FTP Upload

The files to be uploaded will be displayed as shown in Fig 8.3.

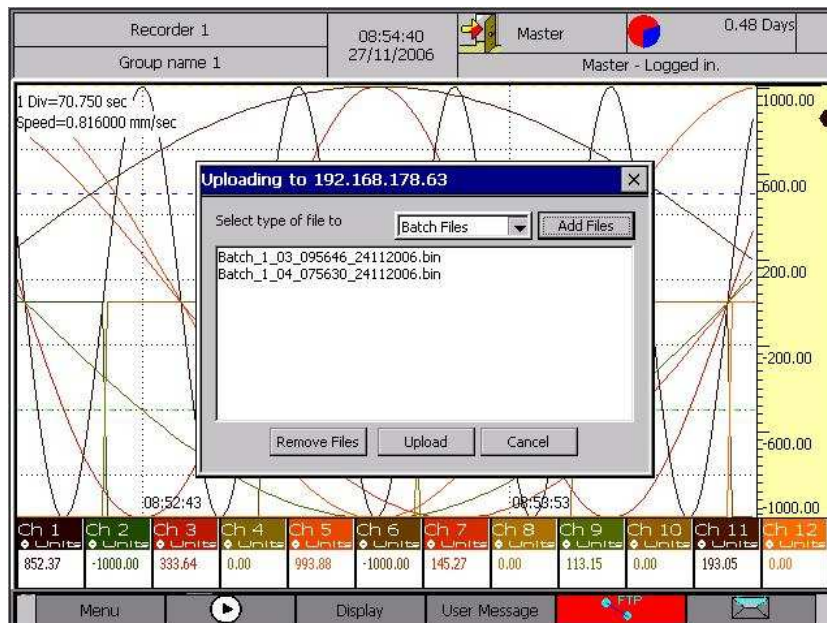

Figure 8. 3: Files to Upload

You can select files of different types to be added to the list as shown in Fig 8.4.

After all the files to upload is selected click on the 'Upload' button. If any of the files have to be removed from the upload list, select that file from the list and click on the 'Remove Files' button. You can remove multiple files from the list at once. The upload can be cancelled by clicking on the 'Cancel' button.

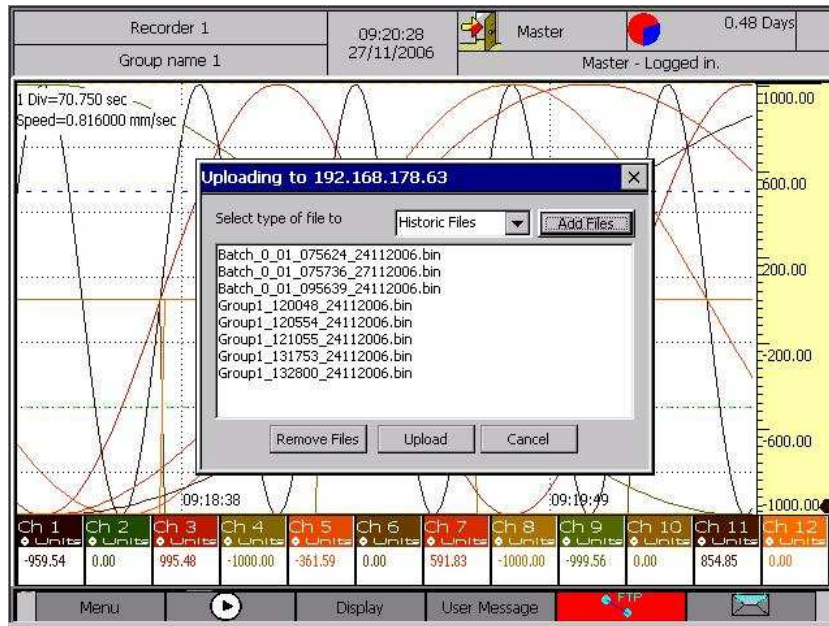

Figure 8. 4: Different files to Upload

Once the 'Upload' button is selected and the files are successfully uploaded the screen will be as shown in the figure 8.5. If the upload was unsuccessful it will display the corresponding error message on the screen. The status of each FTP upload will be entered in the FTP Log and can be viewed in the Interface Status Overview sub option in the Message Overview option in the Display menu. Display->Message Overview->Interface Status Overview ->FTP Status.

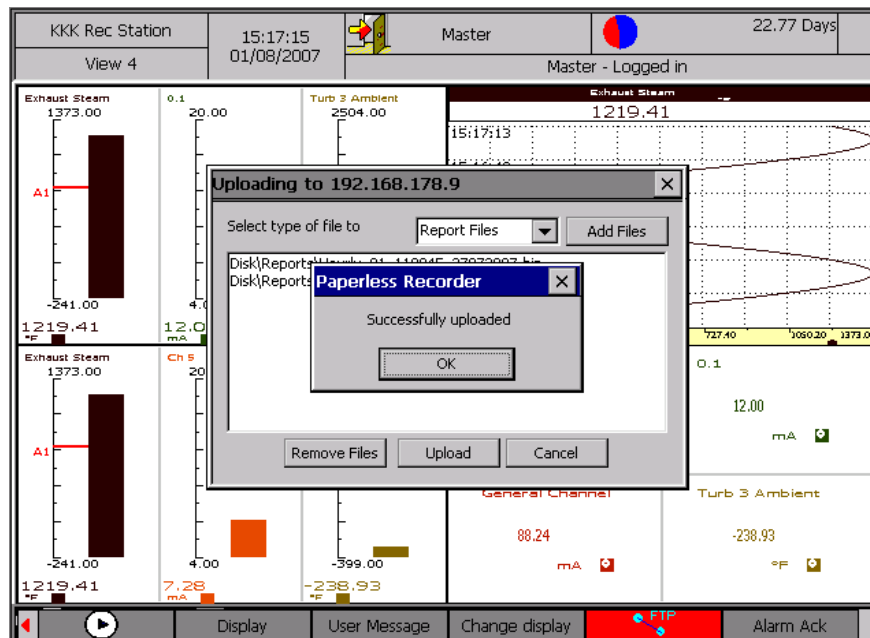

Figure 8. 5: Upload Successful Screen



## 8.2 User Key Email

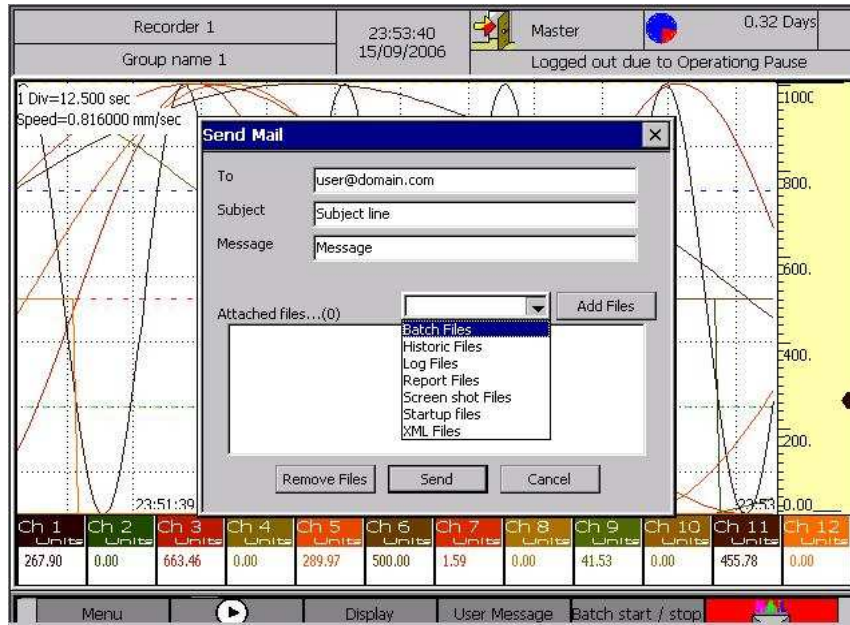

Figure 8. 6: User Key Email

This is similar to FTP Upload option explained in the previous section. You have to enter the email addresses to which the files are to be sent in the 'To' section. You can enter up to five email addresses, each separated by a coma. The subject and message is to be entered in their corresponding sections. Both these sections cannot be left empty.

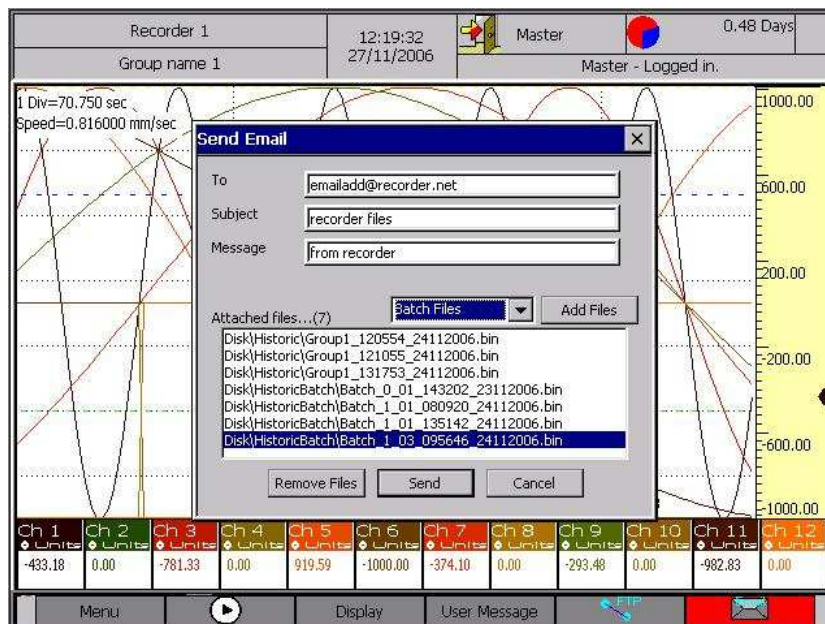

Figure 8. 7: Email Attachment List

You can select the file type from the drop down list. Once the file type is selected click on the 'Add Files' button. You can select the files to be attached from the list displayed. You can also select files of different types to send as attachments in an email as shown in the Fig 8.7. Up to ten files can be sent as attachments (subject to file size.) with an email.

You can remove file/files from the attachment list by clicking on the 'Remove Files' button after selecting them in the list. To send the mail, click on the 'Send' button. You can cancel the mail by clicking on the 'Cancel' button. After the mail has been sent a message indicating success will be displayed, else a message indicating failure will be displayed. The details regarding the email will also be entered in the Email Log, Which you can view from the Interface Status Overview sub option in the Message Overview option in the Display menu. Display->Message Overview->Interface Status Overview ->Email Status.

### 8.3 User Key Screen Shot

The Screen shot user key will be displayed in the short cut bar after it has been added to it from the User Key option in the Basic configuration menu as shown in the Fig 8.8. When you select the key, a screen shot of the recorder is taken and stored. This screen shot file can be sent as attachment with an email, or it can be uploaded using FTP or it can be copied into a USB device. The Screen shot files cannot be viewed on the device. The screen shots are in '.JPEG' format.

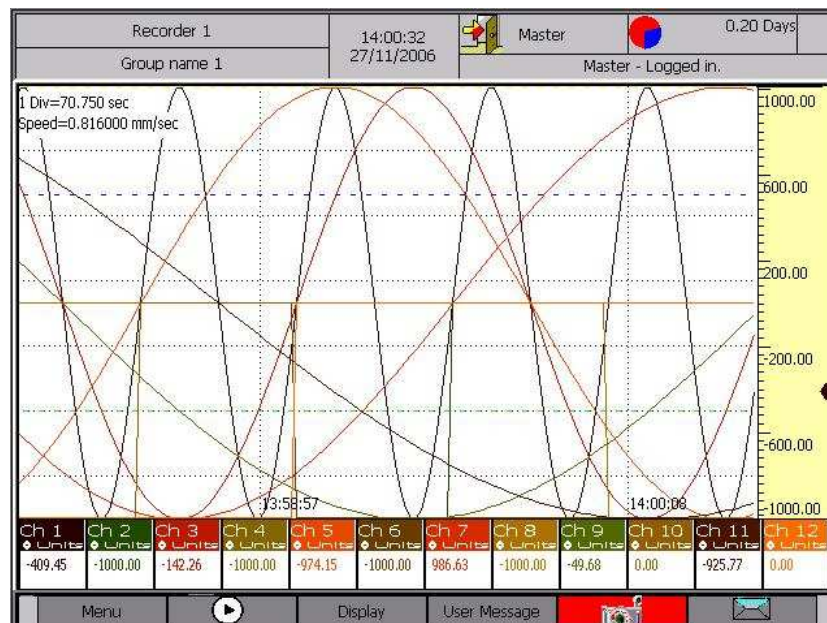

Figure 8. 8: Short Cut Bar with Screen Shot

## 8.4 User Key Batch Start/Stop

You can add the Batch Start/Stop key from the User Key Option in the Basic Configuration menu. It will be displayed as shown in the Fig 8.9. When you select this key the screen will appear as shown in Fig 8.10.

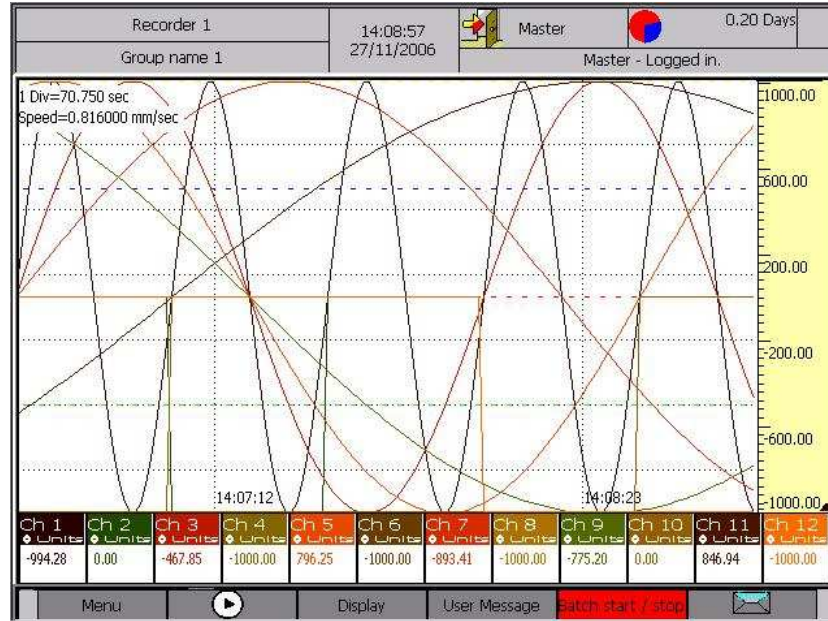

Figure 8. 9: Short Cut Bar with Batch Start/Stop

You can generate batch files only if recording is started or recording is being done. Only those batches whose trigger has been set as User Key can be started using the Batch Start/Stop window. You can stop any batch using the Start /Stop window by selecting the batches to stop, after selecting the 'Stop a Batch' option. Then click on the 'OK' button. The Batch Ids have to be entered in the boxes corresponding to the batches that you are starting. The Batch Ids should be unique, as they are used for distinguishing between the different files of the same batch. By default, the Batch IDs provided in the batch configuration dialog are suggested here.

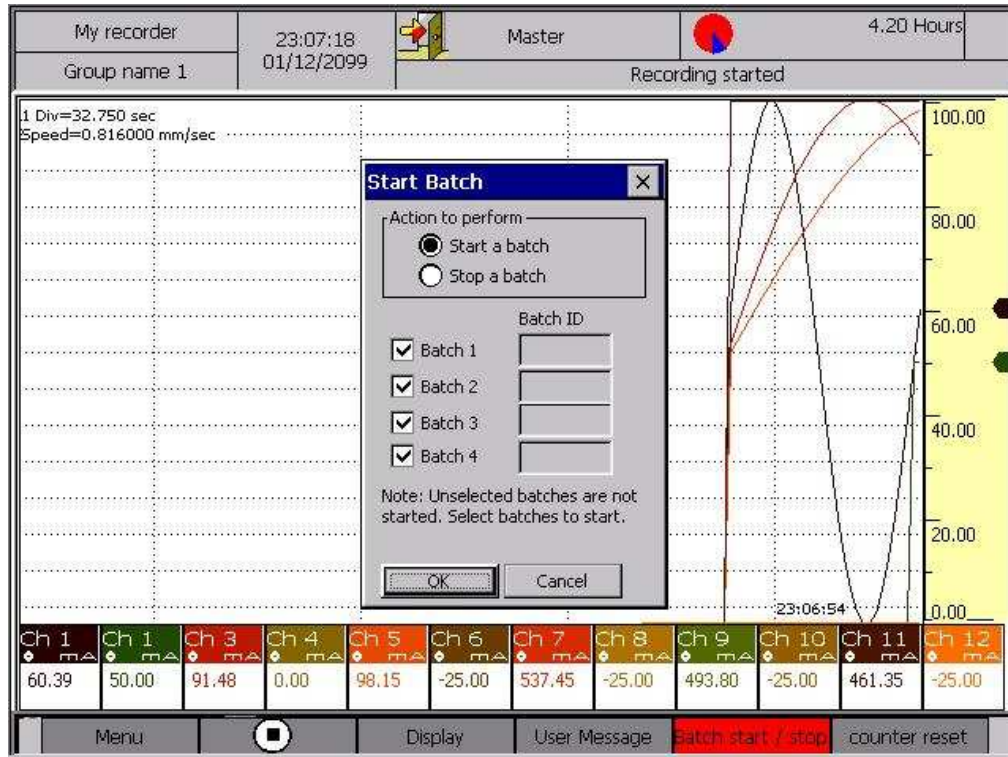

Figure 8. 10: Batch Start/Stop Dialog

### 8.5 User Key Counter Reset

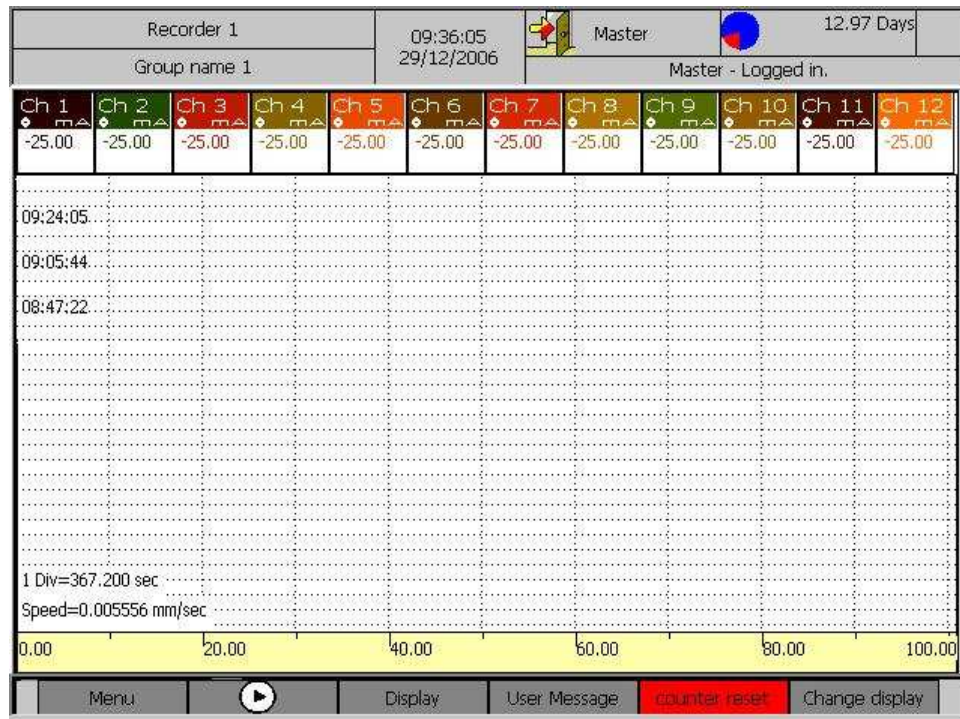

Figure 8. 11: Batch Start/Stop Dialog

By setting this option for user key, user can reset any of digital counter channels. For this user needs to select the user key reset in the channel configuration dialog.

## 8.6 User Key Reset Cal

Just like the counter Reset key, Reset Cal user key causes all the calculation channels (that are configured to be RESET via user key) to reset to zero.

## 8.7 User Key Hide / Disp Scale

For every group displayed on screen, numeric display section will be displayed by default. If scales are enabled for channels configured in that group, then scales will be plotted on the graph. If you don't want to display scales at all then you can use this user key. You can add the Hide/Display Scale key from the User Key Option in the Basic Configuration menu.

When this user key is pressed graph, current group on screen will be reinitialized and it'll be displayed without scales. This user key is available only for the groups and not for combination views, batch and Historic data.

In figure 8.12 below group 1 is shown with numeric displays turned off and subsequently, figure 8.13 shows it with scales turned off.

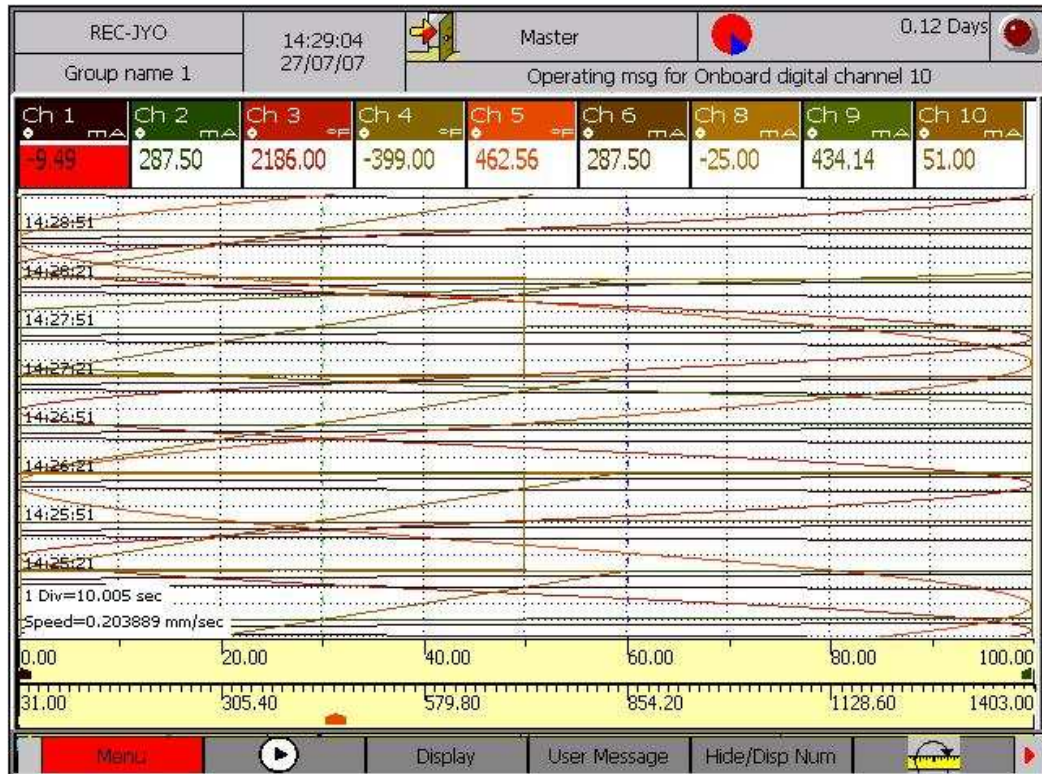

Figure 8. 12:

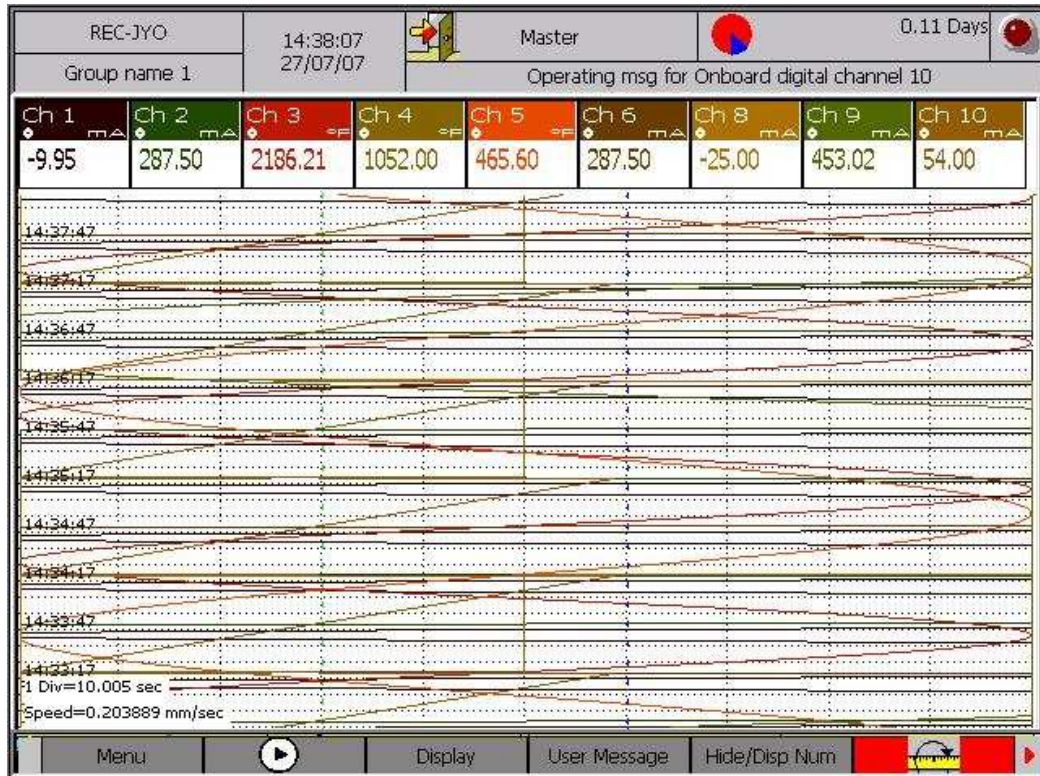

Figure 8. 13:

## 8.8 User Key Hide/ Disp Num

You can hide or display the numeric display section of the graph using this user key. When this user key is pressed graph for the current group on screen will be reinitialized and it will be displayed without numeric display section. This user key is available only for the groups and not for combination views, batch and Historic data. After pressing Hide/Display Numeric key

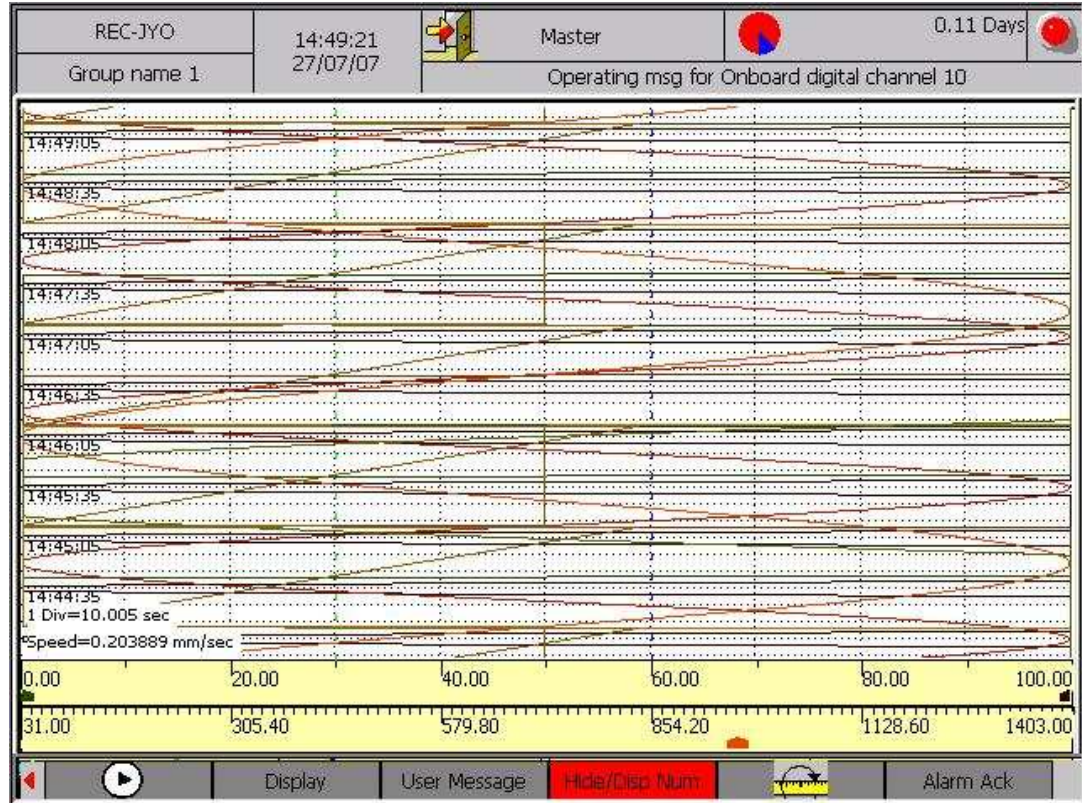

Figure 8. 14: Batch Start/Stop Dialog

## 8.9 User Key Change Display

A group can be plotted in four different ways (Bar, numeric, horizontal, vertical). You can view all those four graph styles of a group using this user key. Group 1 display type is 'Horizontal' but using user key 'Change Display', you can view 'Vertical Trend Display' of same group. This user key won't work if currently displayed group is Combination view or Historic data/batch and live batch. You can view 'changed display type' group temporarily (graph won't be reinitialized) or permanently (all graphs/combination views will be reinitialized). In first case, combination view which includes current group on screen, that group's display type won't be changed in combination view whereas in latter's case, group display type of group will be changed on screen as well as in combination view.

First case: Change display type temporarily;

In this group 1 display type is Horizontal as per group configuration. Press Change Display user key. Then following dialog will be displayed on screen.

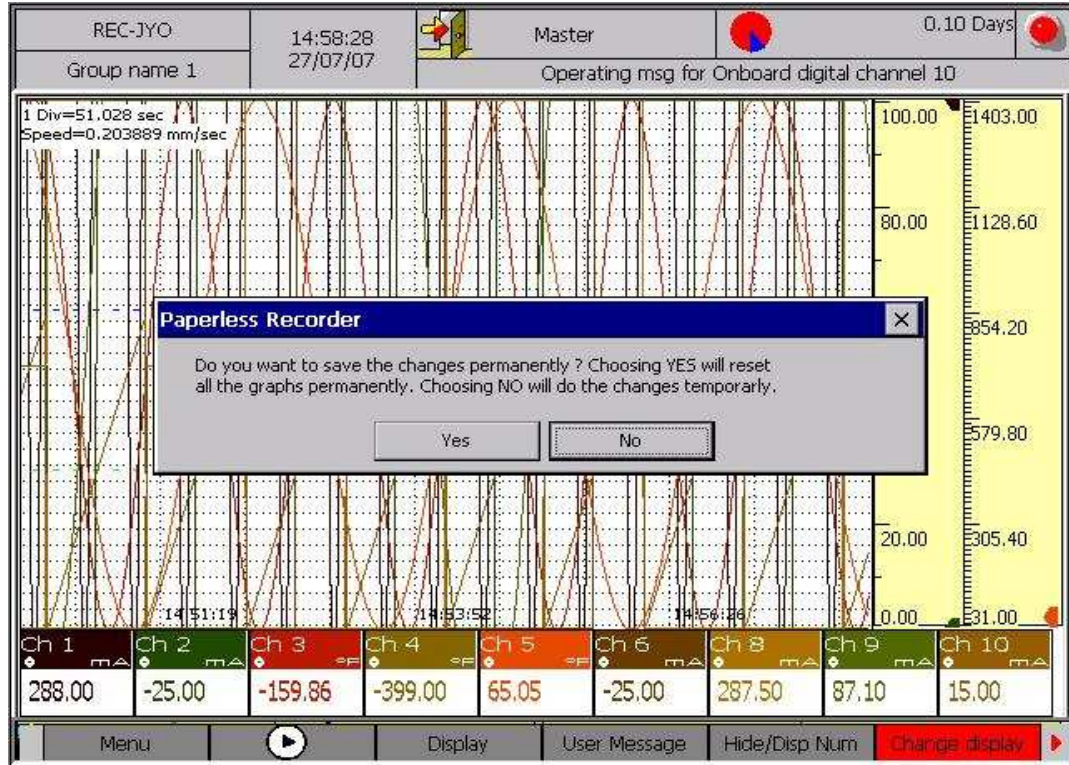

Figure 8. 15: Batch Start/Stop Dialog

Press 'No' to reset graph. Vertical trend display of Group 1 is displayed on the screen.

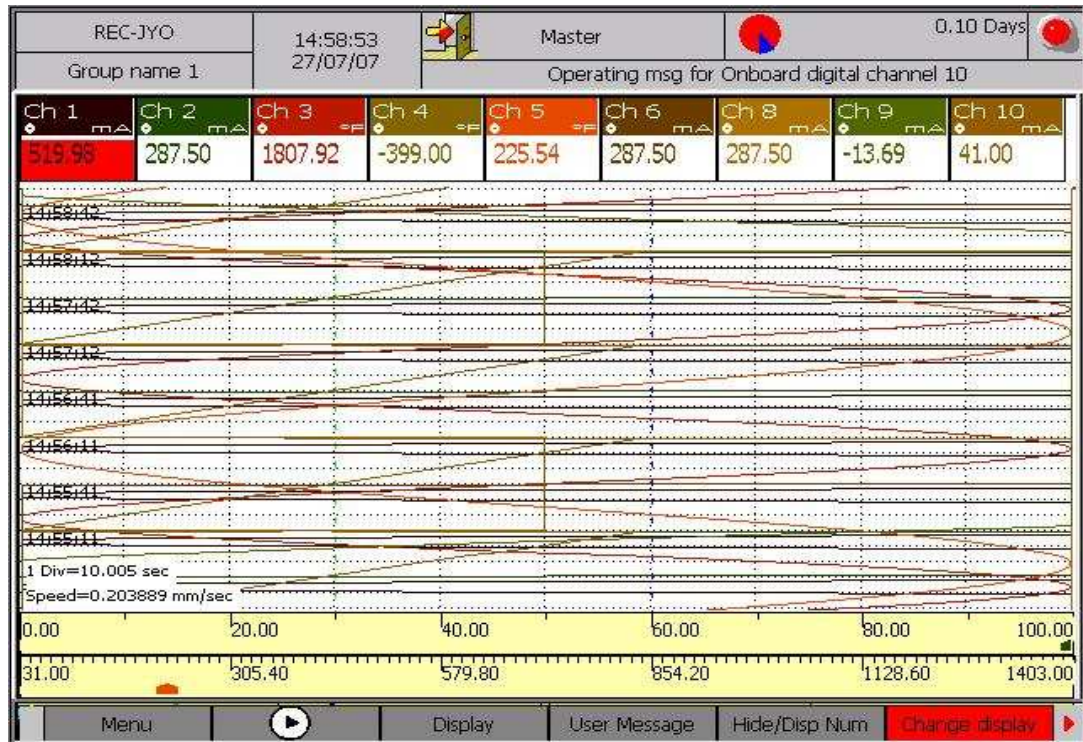

Figure 8. 16: Batch Start/Stop Dialog



Combination view 3 consists of group1 and group 3 as per display configuration.

After pressing 'change display' user key, display type of group 1 in combination view will not be changed .See figure 8.17 below.

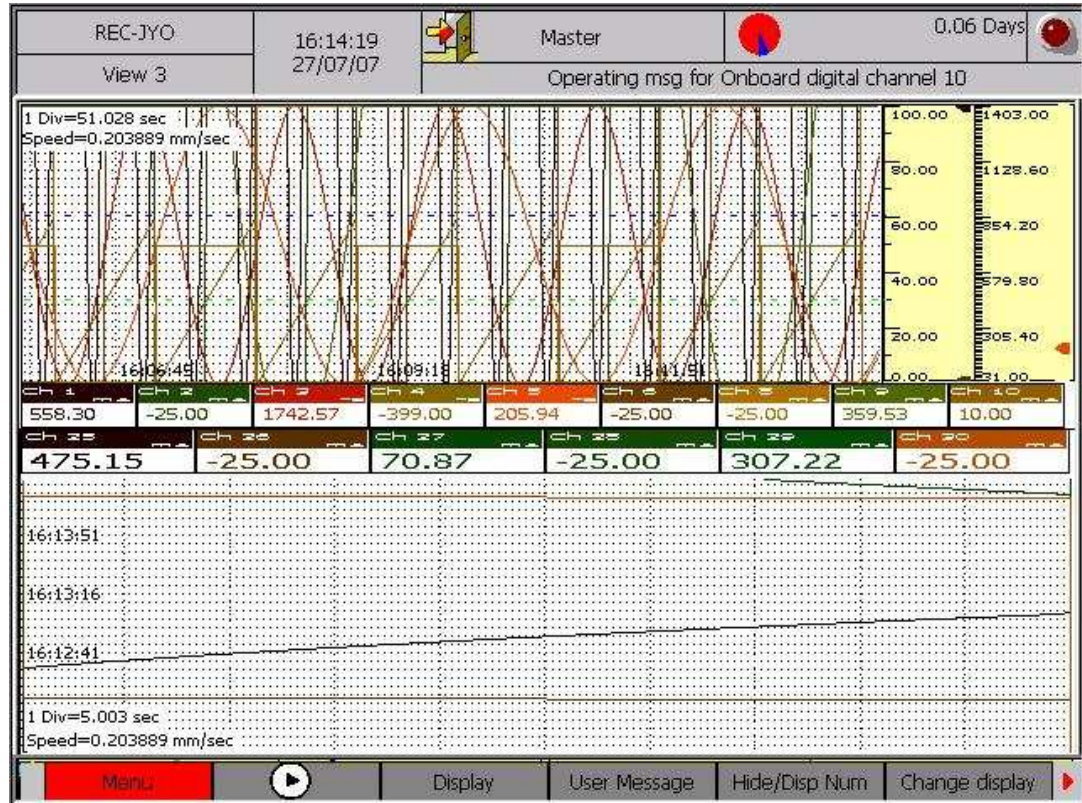

Figure 8. 17: Batch Start/Stop Dialog

Second case: Change display type permanently

Initially group display type of group 1 set to 'Horizontal' in group configuration.

Press change display key and press 'Yes' to reset all the graphs. Group display type of group 1 will be changed to Vertical .This change will appear both on the group displayed on screen that is group 1 and in combination view 3 which includes this group.

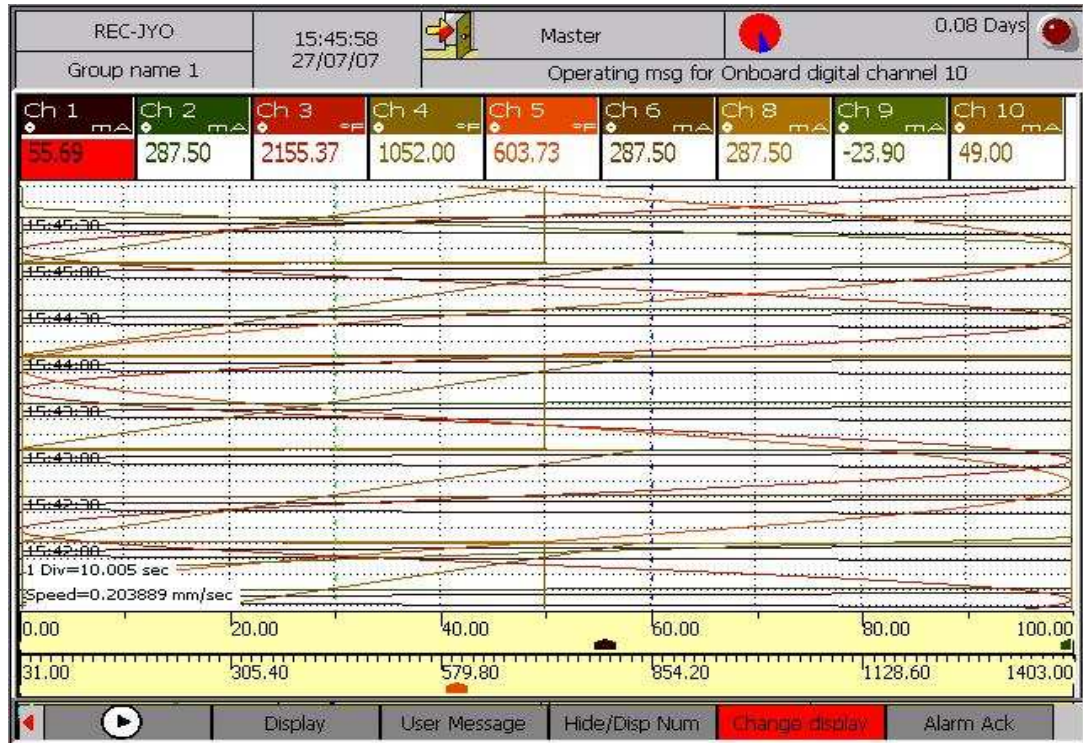

Figure 8. 18: Batch Start/Stop Dialog

See combination view 3 which includes above group

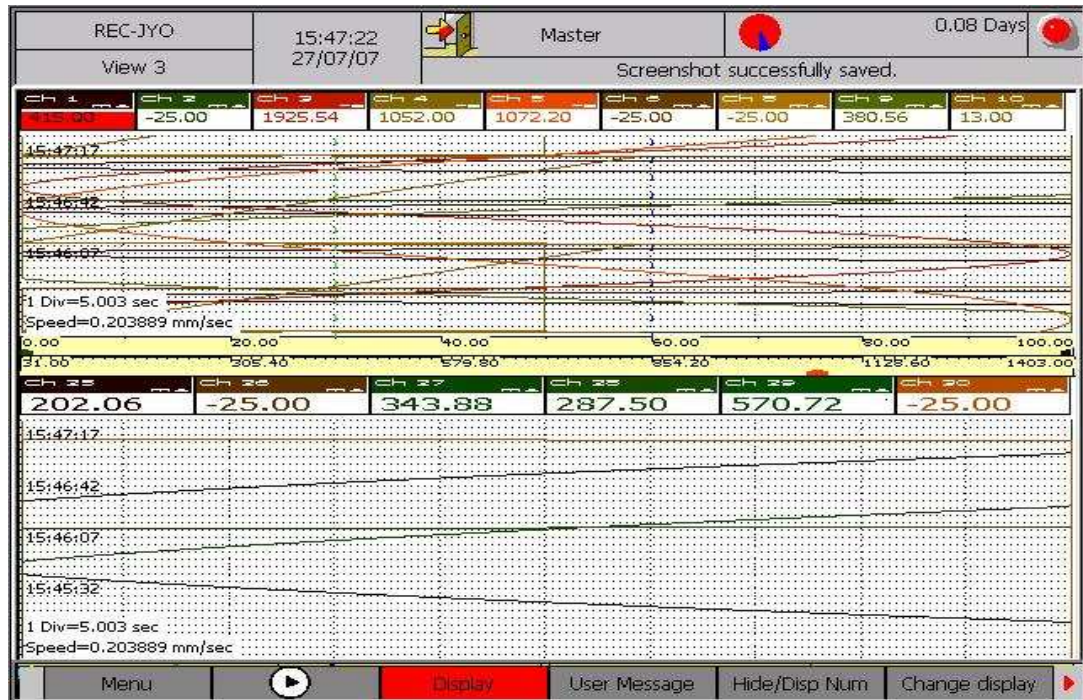

Figure 8. 19: Batch Start/Stop Dialog

## 9 Browser Overview and Functionality

### 9.1 Start-up and Main Screen

To access the web browser application use web browser like Microsoft Internet explorer 6.0, enter the recorder site name in the address bar, for e.g. <http://192.168.6.125/index.html>, where the 192.168.6.125 is the IP address of the recorder.

Note: The Browser Application Tool will support only the Microsoft Internet Explorer 6.0 and above version.

Recorder's site opens with the start up image.

Note: The right side image depends on the 'Star-up image' configuration.

#### 9.1.1 Main Screen Overview

Once the site is opened, the following screen appears

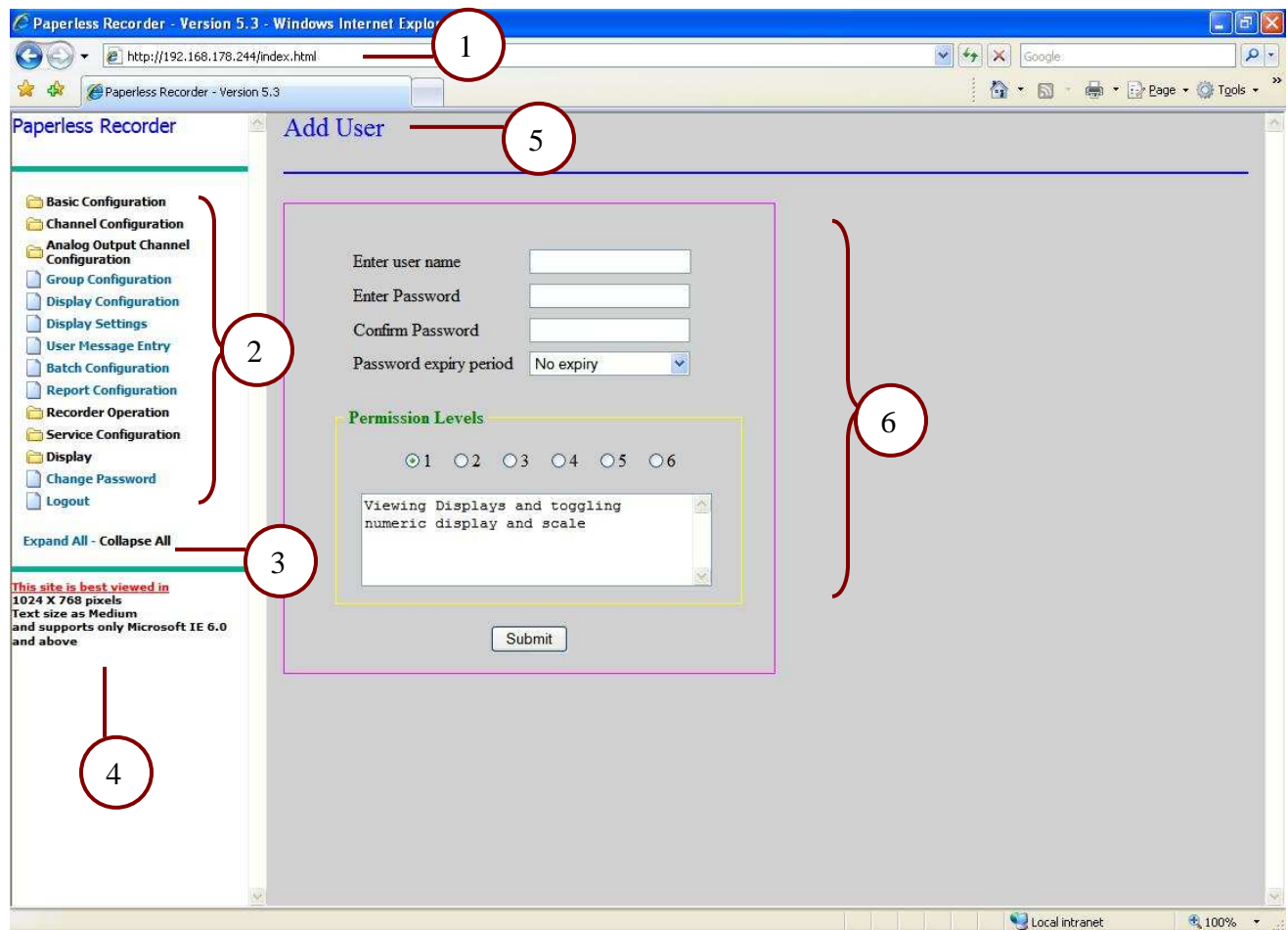

Figure 9. 1: Main Screen

In the above figure

1. It is the combination of the IP address of the recorder and the Index.html
2. It displays the tree-structured menu having the following hierarchy.

- 1.1 Basic Configuration
  - 1.1.1 Authentication
    - 1.1.1.1 Log-In
    - 1.1.1.2 Add User
    - 1.1.1.3 View/Edit User
    - 1.1.1.4 Enable Login
  - 1.1.2 Communication
    - 1.1.2.1 MODBUS Settings
    - 1.1.2.2 Ethernet Settings
    - 1.1.2.3 DNS Settings
    - 1.1.2.4 FTP Settings
    - 1.1.2.5 FTP Scheduling
    - 1.1.2.6 Email Settings
    - 1.1.2.7 Schedule Email
    - 1.1.2.8 Browser Application Permission
  - 1.1.3 Enable Help
  - 1.1.4 Internal Memory Function
  - 1.1.5 Languages
  - 1.1.6 Temperature
  - 1.1.7 Alarm Relays
  - 1.1.8 Data and Time
  - 1.1.9 Device Data
  - 1.1.10 Memory Alarm Configuration
  - 1.1.11 Operating Pause
  - 1.1.12 Timer
  - 1.1.13 User Keys
- 1.2 Channel Configuration
  - 1.2.1 Analog Input Channels
  - 1.2.2 Calculation Channels
  - 1.2.3 External Channels
  - 1.2.4 Digital Input Channels
- 1.3 Analog Output Channel Configuration
  - 1.3.1 Analog Output Channels
- 1.4 Group Configuration
- 1.5 Display Configuration
- 1.6 Display Settings
- 1.7 User Message Entry
- 1.8 Batch Configuration
- 1.9 Report Configuration
- 1.10 Recorder Operation

- 1.10.1 Operations
- 1.10.2 Generate Message
- 1.10.3 Download Files
- 1.11 Service Configuration
  - 1.11.1 Hardware I/O Simulation
- 1.12 Display
  - 1.12.1 Groups
    - 1.12.1.1 Group1
    - 1.12.1.2 Group2
    - 1.12.1.3 Group3
    - 1.12.1.4 Group4
    - 1.12.1.5 Group5
    - 1.12.1.6 Group6
    - 1.12.1.7 Group7
    - 1.12.1.8 Group8
  - 1.12.2 Combination View 1
  - 1.12.3 Combination View 2
  - 1.12.4 Combination View 3
  - 1.12.5 Combination View 4
  - 1.12.6 Measurement Value Overview
  - 1.12.7 Message Overview
    - 1.12.7.1 Alarms
    - 1.12.7.2 User Messages
    - 1.12.7.3 Device Messages
    - 1.12.7.4 Interface Status Overview
      - 1.12.7.4.1 MODBUS Status
      - 1.12.7.4.2 FTP Status
      - 1.12.7.4.3 Email Status
    - 1.12.7.5 Device Information
  - 1.12.8 Historic Display
  - 1.12.9 Batch Display
  - 1.12.10 Reporting Display
- 1.13 Change Password
- 1.14 Logout

3. Displays the two operations that may be performed on the tree-structured menu
  - Expand All - This will expand all the folders present in the tree-structured menu i.e. it will, display all the page links present in the folder.
  - Collapse All - This will collapse all the folders present in the tree-structured menu.
4. Displays the best configuration for properly viewing the site.
5. Displays the header of the currently open page.
6. Displays the page containing controls, graph area.

### 9.1.2 Login Procedure

The main menu of the browser application can be directly accessed only when the login option is disabled in the authentication menu of the '*Basic Configuration*' menu. If you click on any of the left side link the following screen will be displayed.

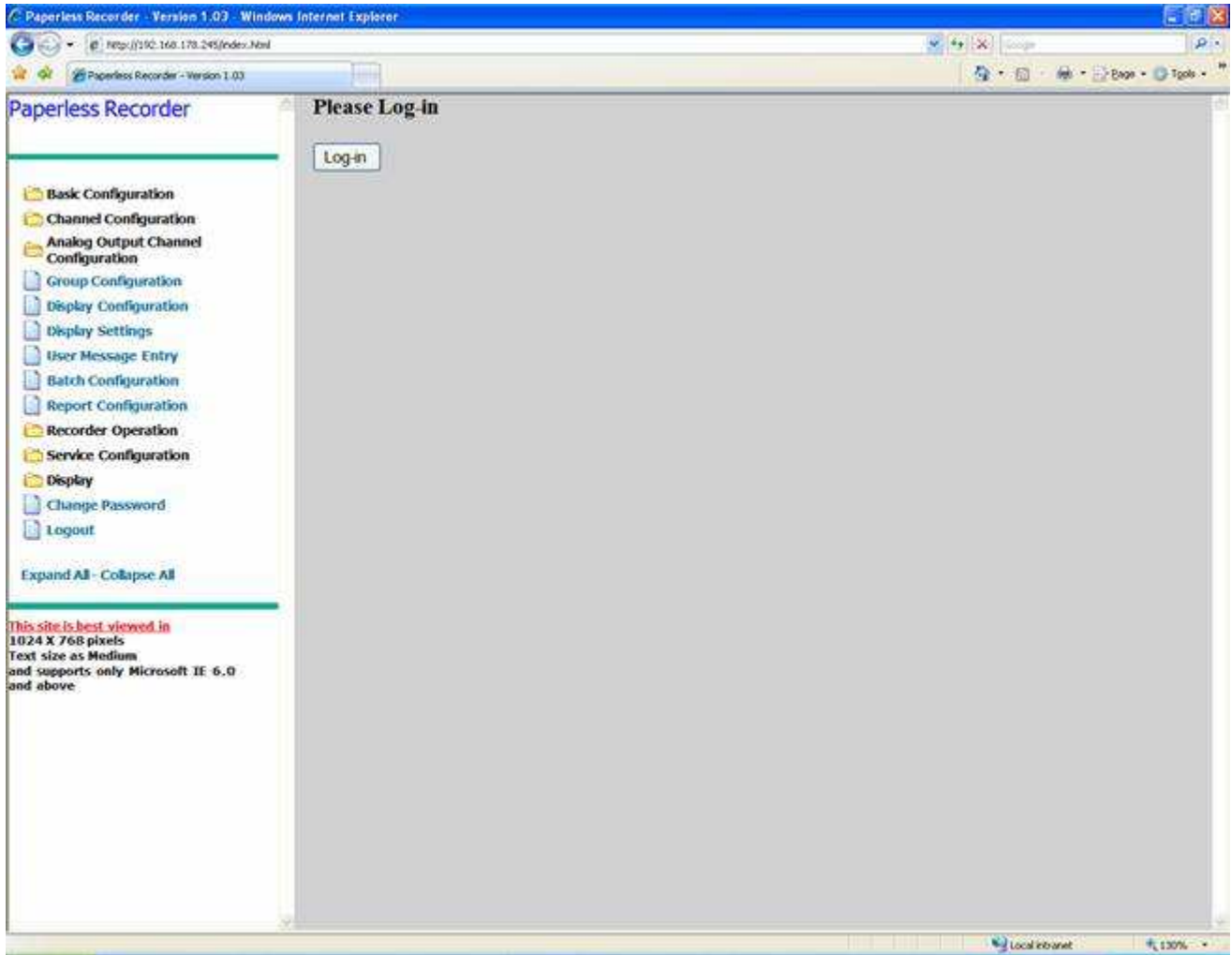

Figure 9. 2: Login Screen

After clicking the '*Login*' button it will display the *User List* screen from which you can select a user name from the '*Select User*' box. The '*Select User*' box contains the list of user names that have been configured in the recorder. After selecting the user name enter the corresponding password in the '*Password*' field to login as shown in figure below. The password field will always display dots.

Each user will be allowed to have his/her own password expiry period.

The password expiry message will be shown to the user from 2 days before the expiry. Once the user password is expired, user will not be allowed to login without changing the password.

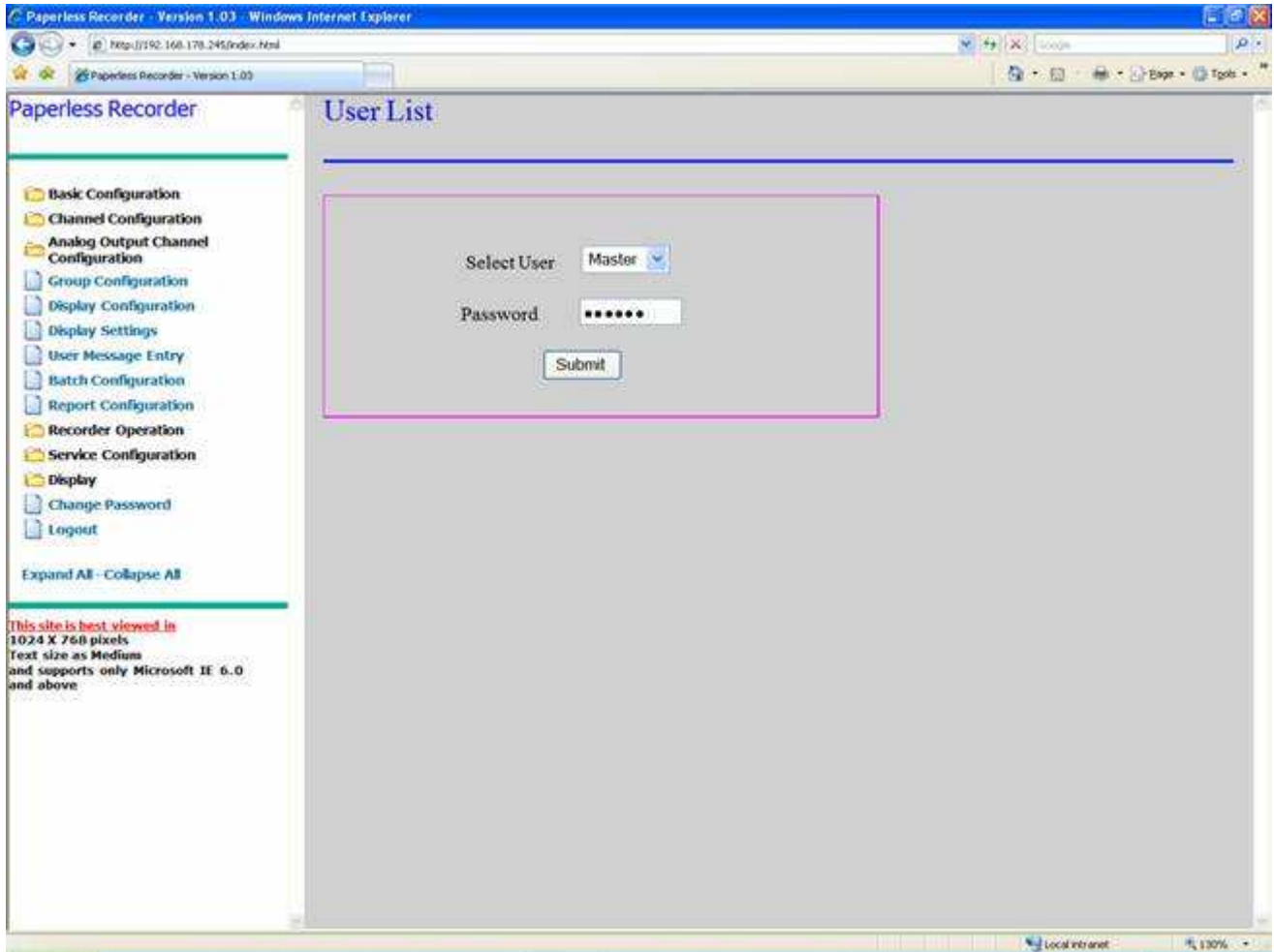

Figure 9. 3: User List

After entering the valid password user has to press '*Submit*' button to accept the password. After a successful login, the following screen will display, showing "Logged in successfully". Now you may access the different recorder function provided by the site, according to the permission level assigned to you. To access the channel configuration page, you have to click on the **Channel Configuration** link present in the tree-structured menu list. The '*Back*' button of every page will go to the previous link of the tree-structured menu list. The '*Submit*' button of every page is to save the new settings. Once the recording is ON you can't change the recorder configuration settings.

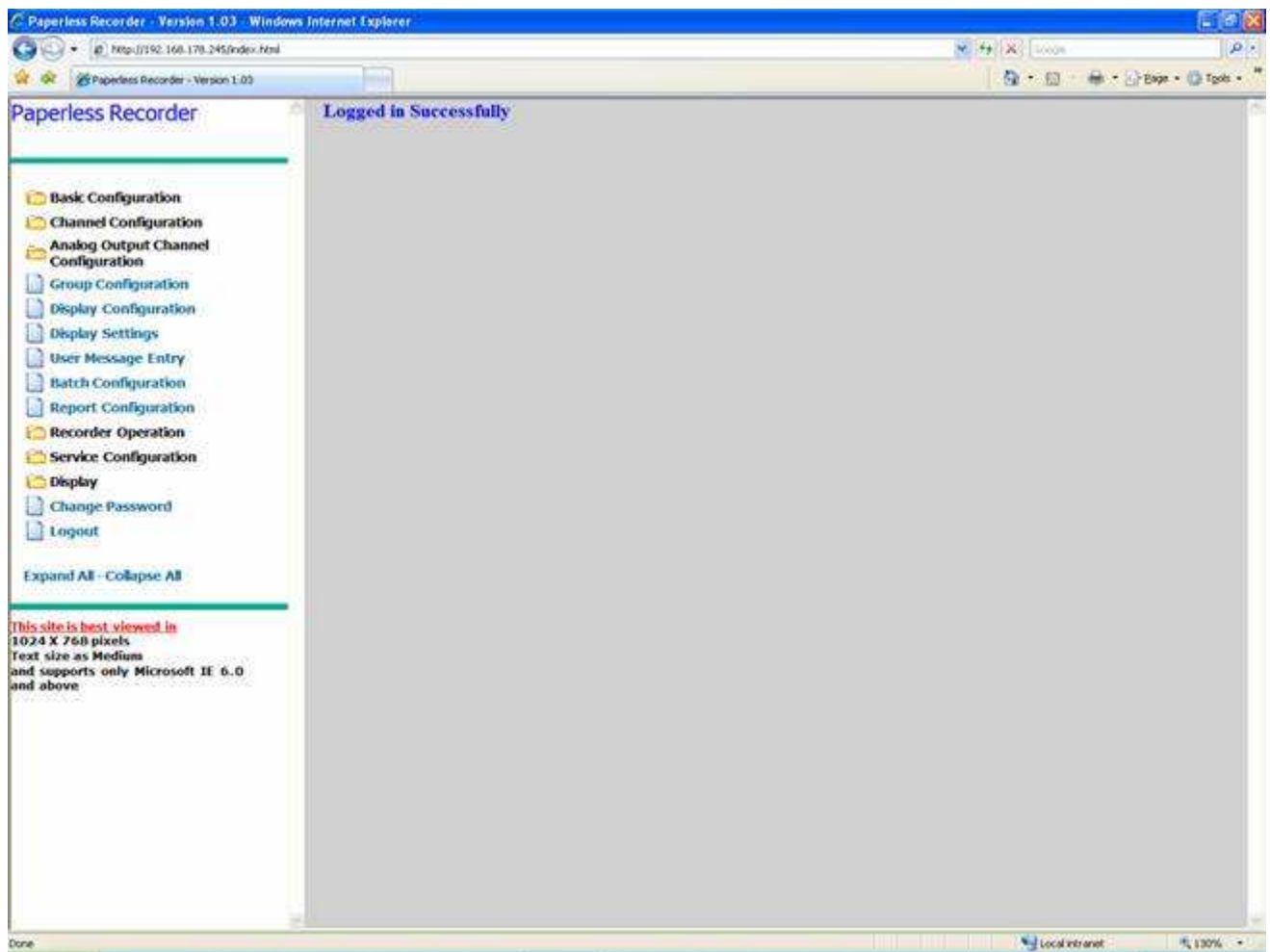

Figure 9. 4: Screen after successful login

## 9.2 Menu

### 9.2.1 Basic Configuration

The '*Basic configuration*' menu is shown below.



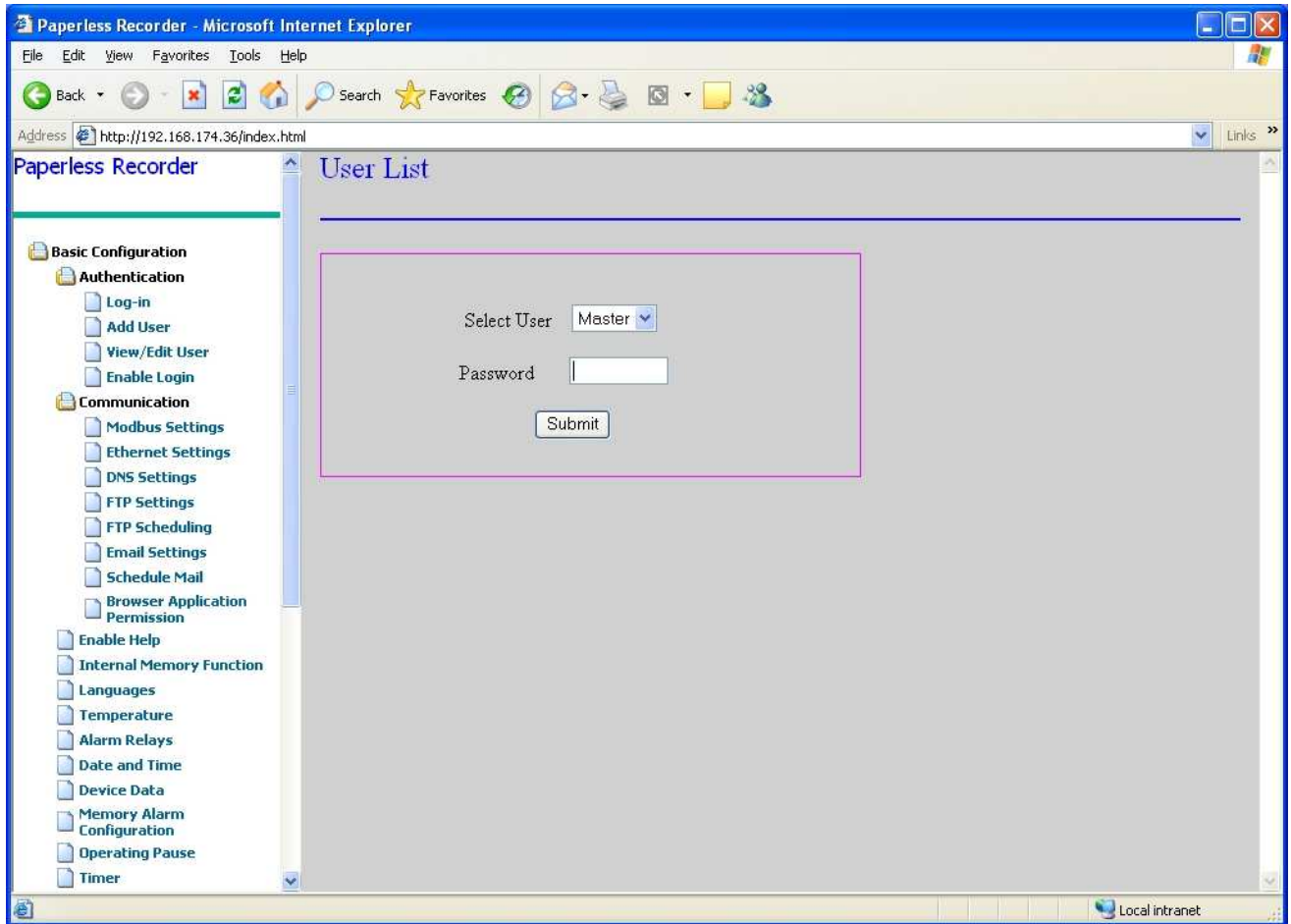

Figure 9. 5: Basic Configuration Menu

### 9.2.1.1 Authentication

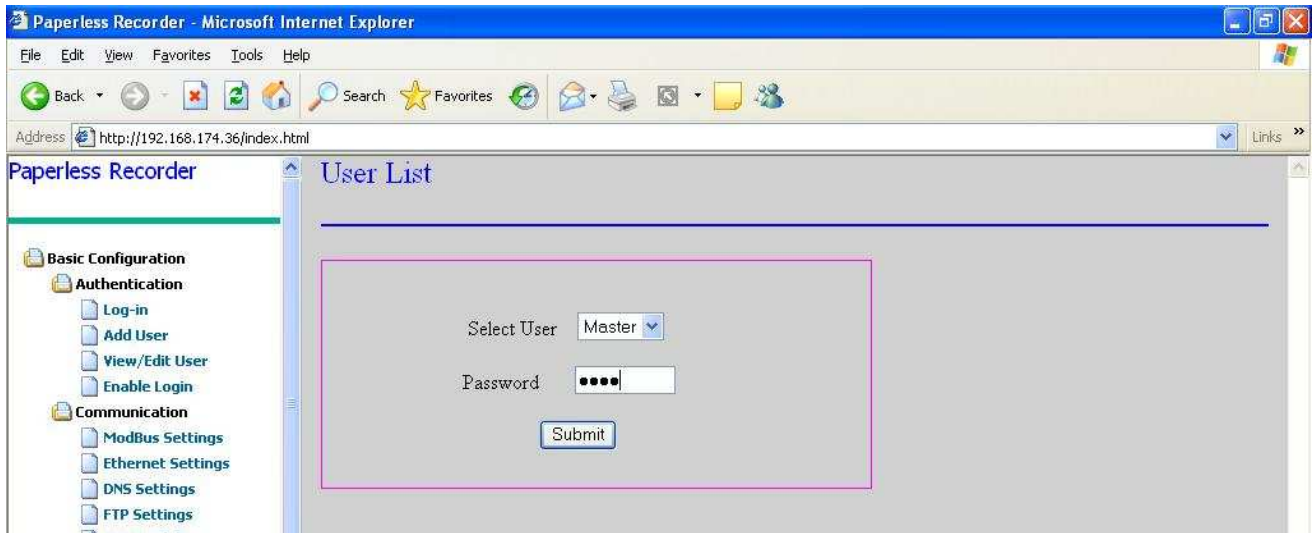

Figure 9. 6: Authentication Menu

The 'Authentication' option of the 'Basic Configuration' provides the options for adding, deleting a user. In addition to this it provides the option to view and edit the user's settings. It also provides the option for enabling/disabling the login control. Only the 'Master User' can enable this option.

The following options are available in *Authentication* menu,

- Authentication
  1. Log-In
  2. Add User
  3. View/Edit User
  4. Enable Login

Note: These options are available if and only if login is enabled.

### 9.2.1.1.1 Log-In

In this page you may select a user name from the drop down menu. After entering the corresponding password in the 'Password' field click on 'Submit' button.

Note: By default Enable Login factory settings will set to disable state for the first boot of the device. From the subsequent login device will boot according to configuration.

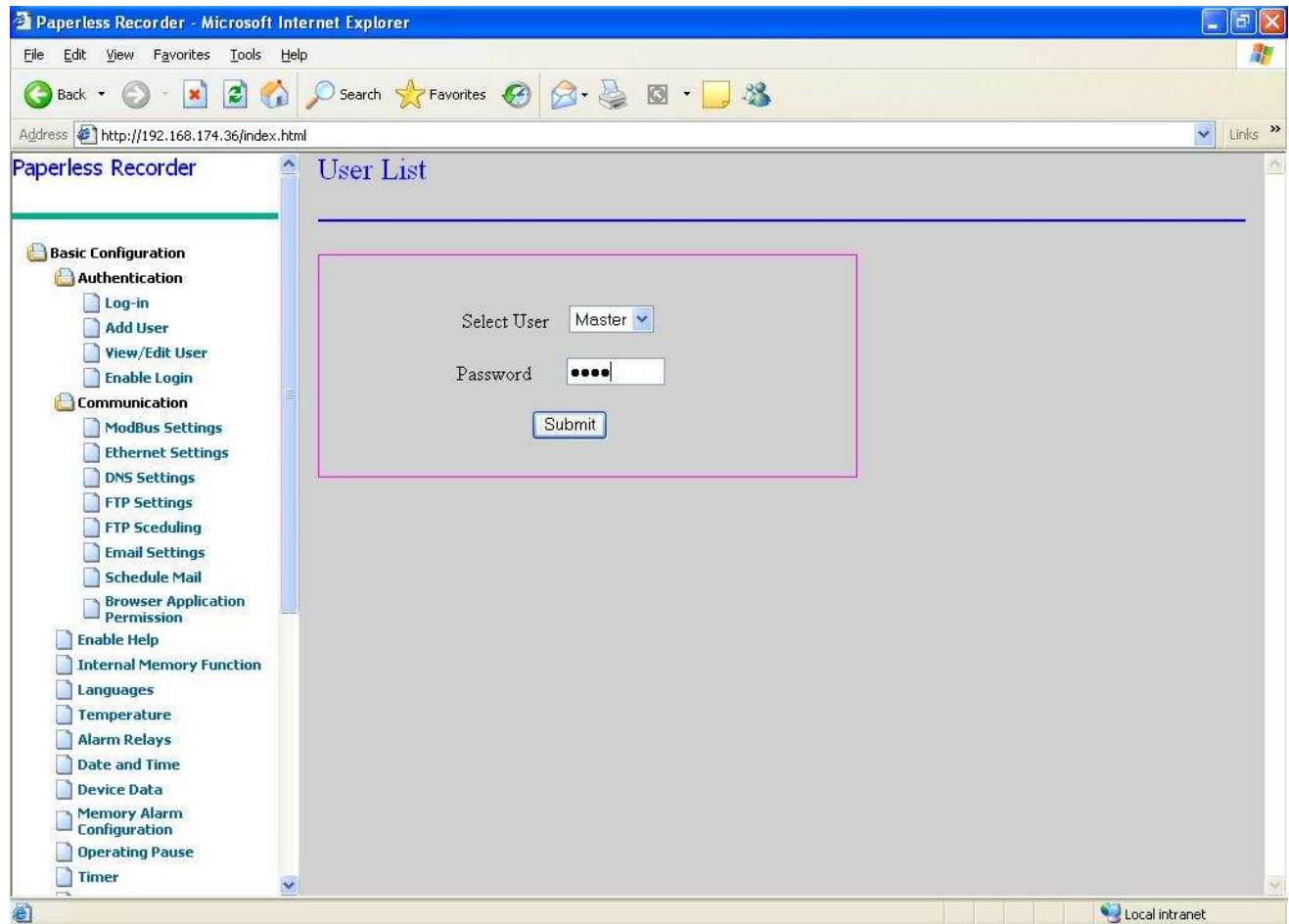
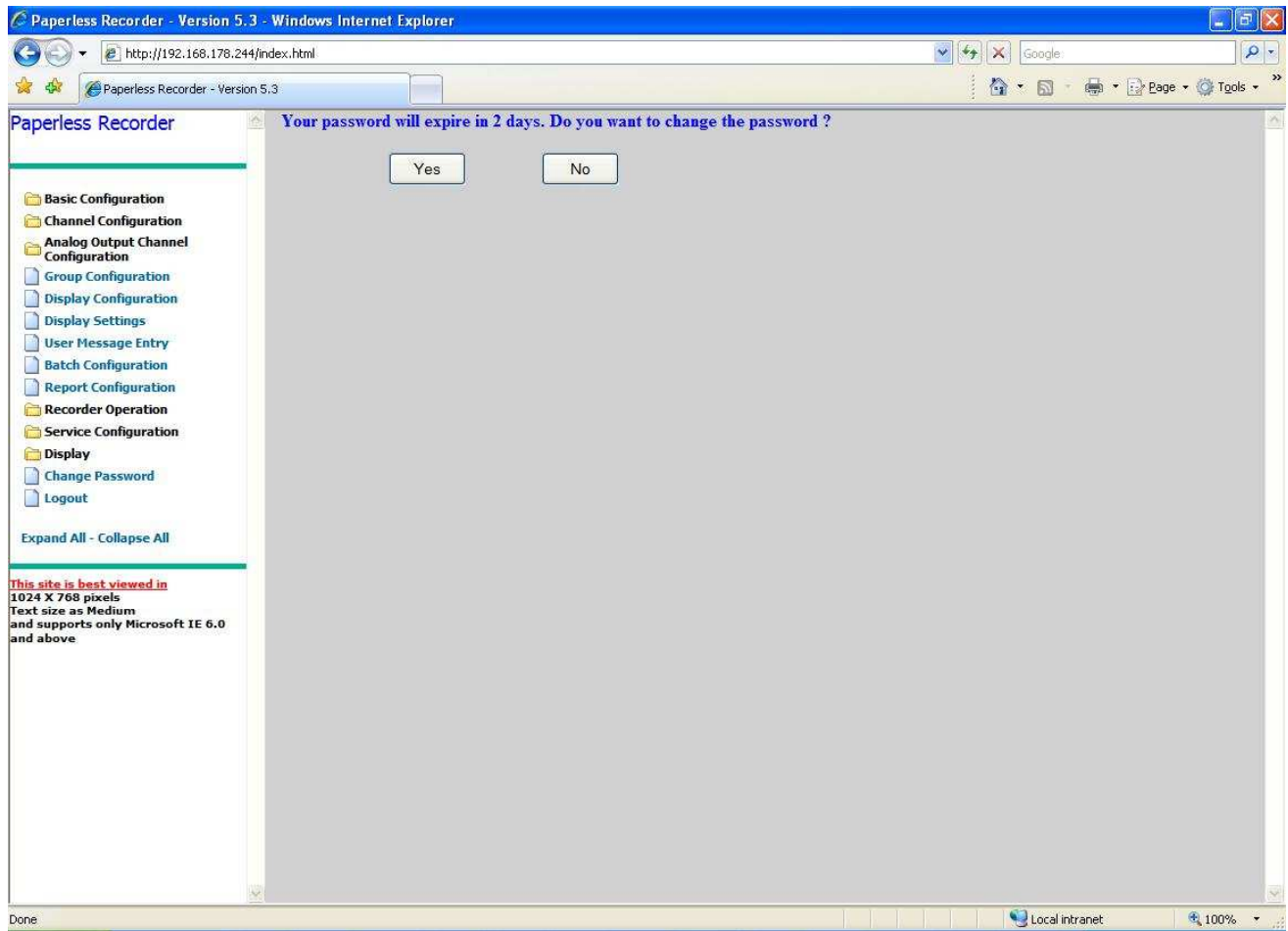

Figure 9. 7: Login Screen

The password expiry message will be shown to the user from 2 days before the expiry. Once the user password is expired, user will not be allowed to login without changing the password.

If 2 days are left for the logged in user's password expiry then after logging in, the following screen will be shown.



If one day is left for the logged in user's password expiry then after logging in, the following screen will be shown.

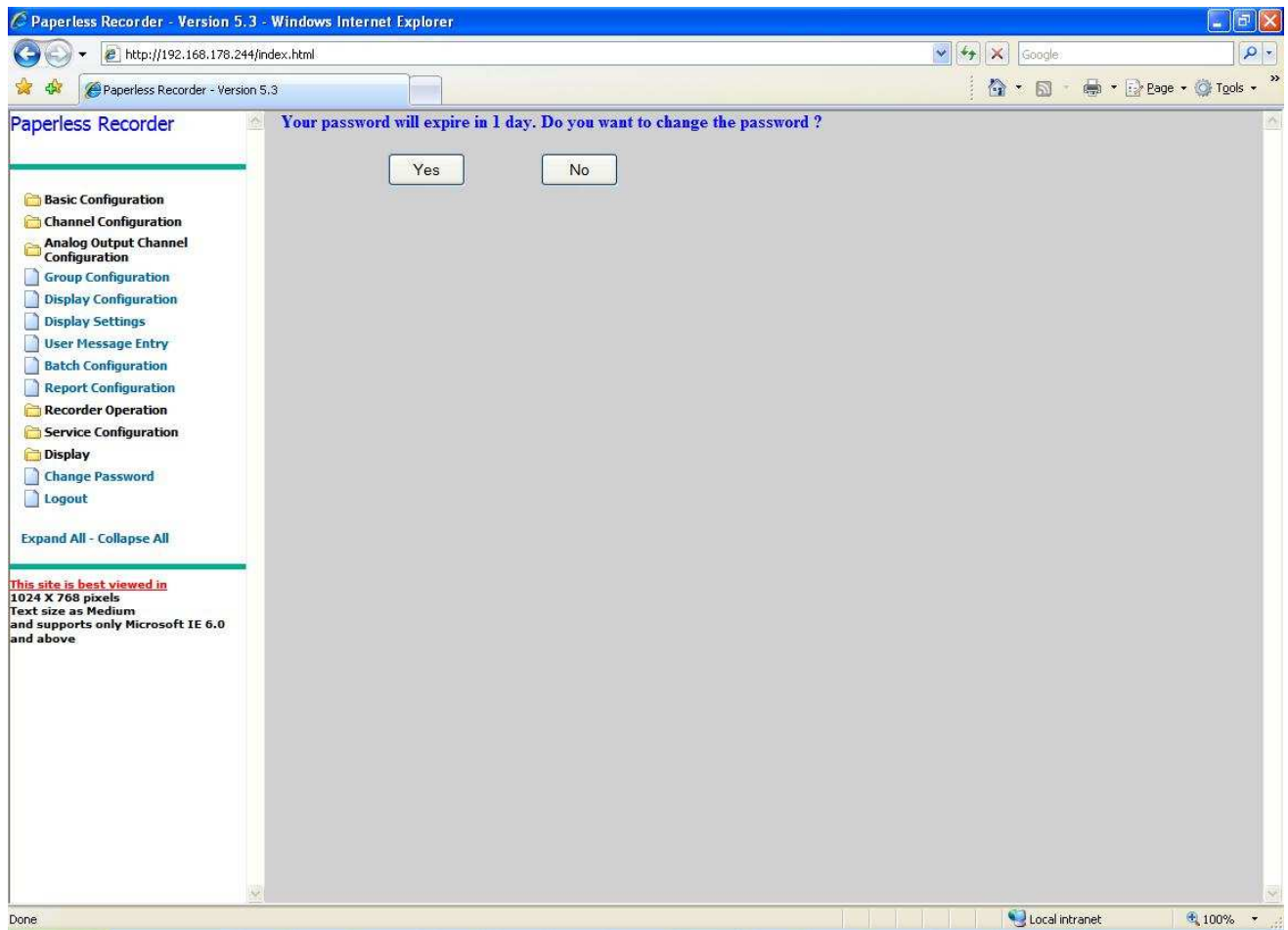

If the expiry day has reached then the following screen will be shown.

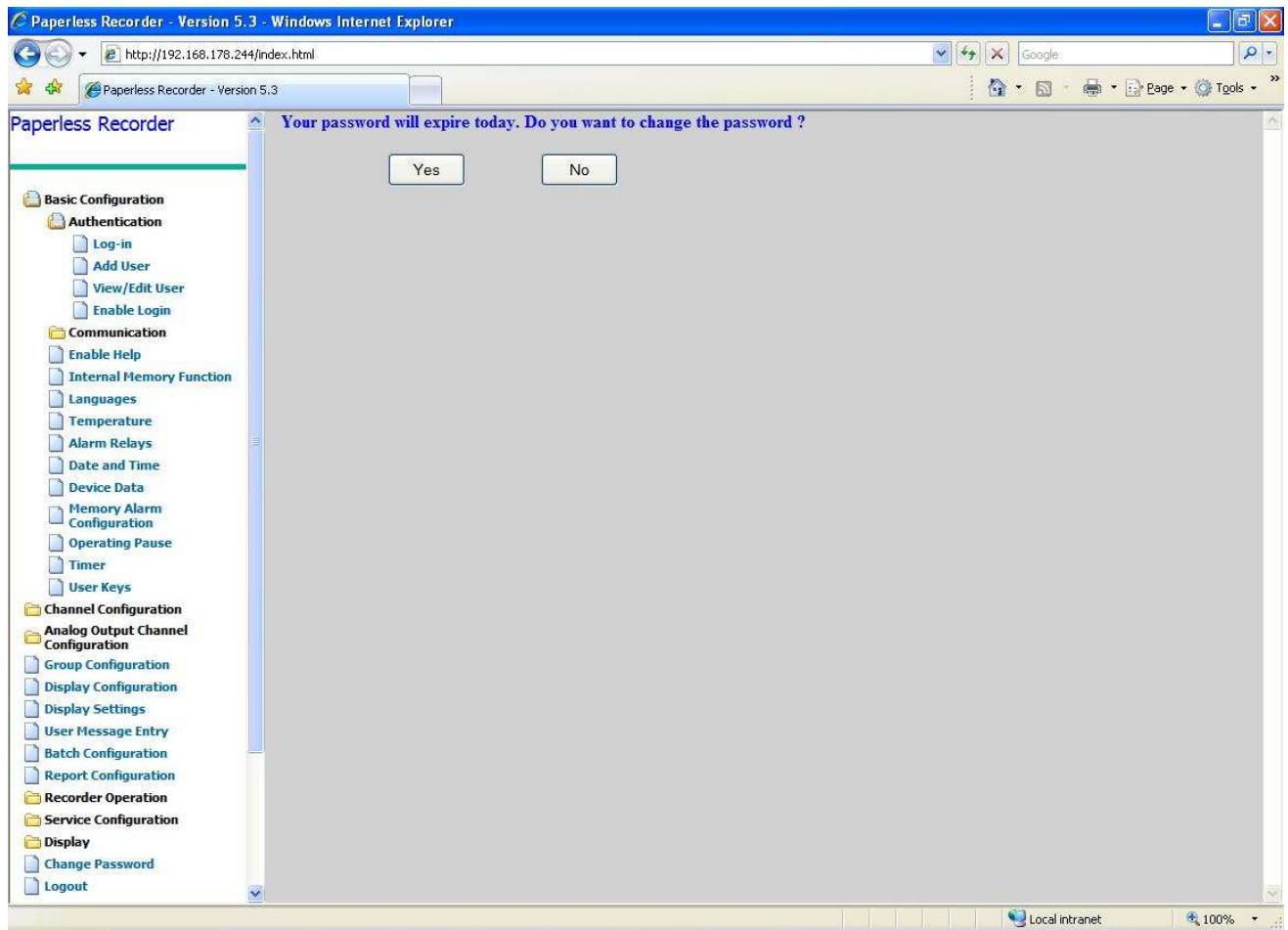

In above 3 screens if the user selects *Yes* button *Change password* page will open as shown below.

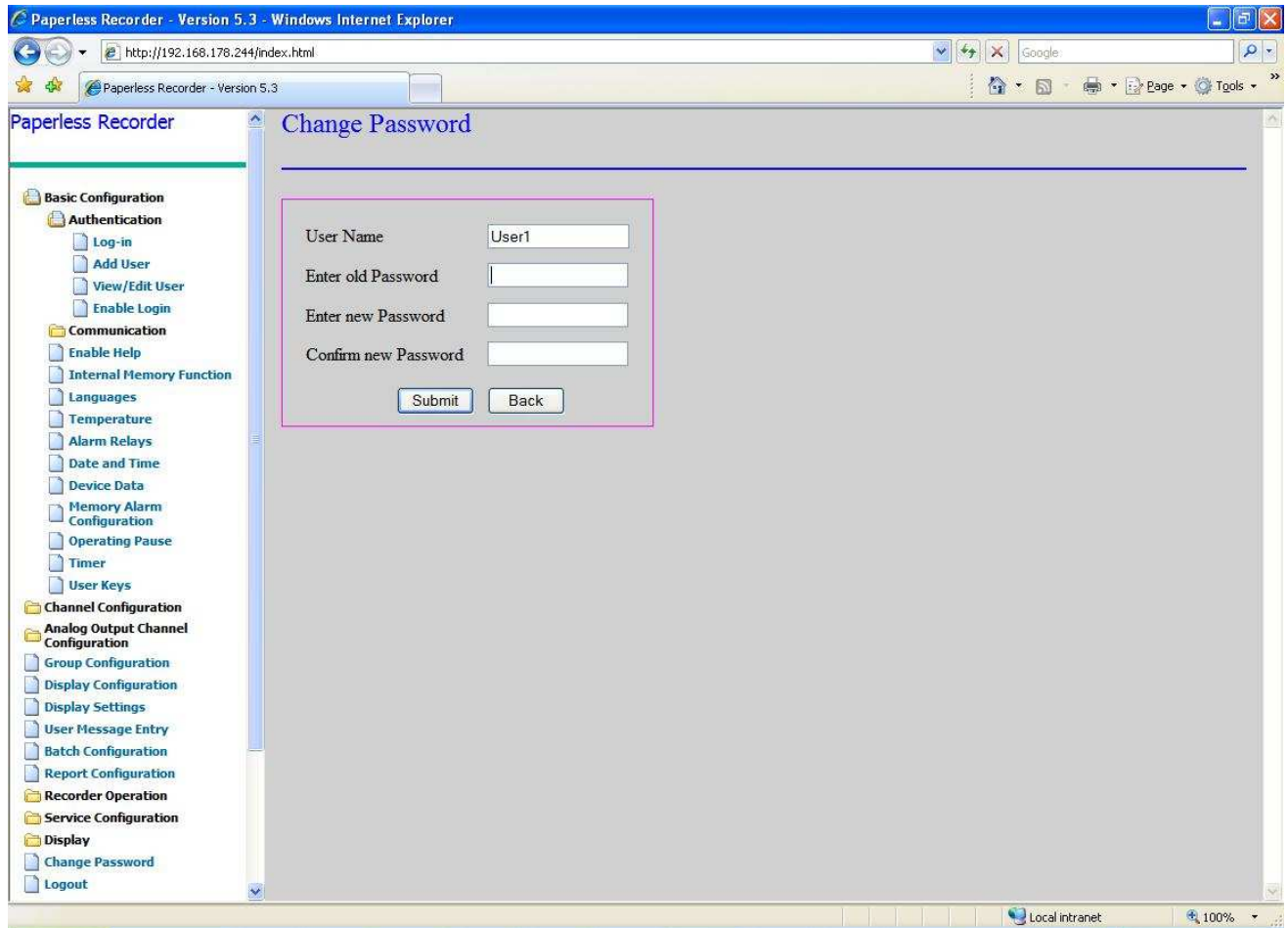

If user presses *No* button in the screen which shows a message about password expiry in 1 or 2 days then screen shown below will be invoked.

Once the user changes the password the password expiry date will be update according to the password expiry period selection.

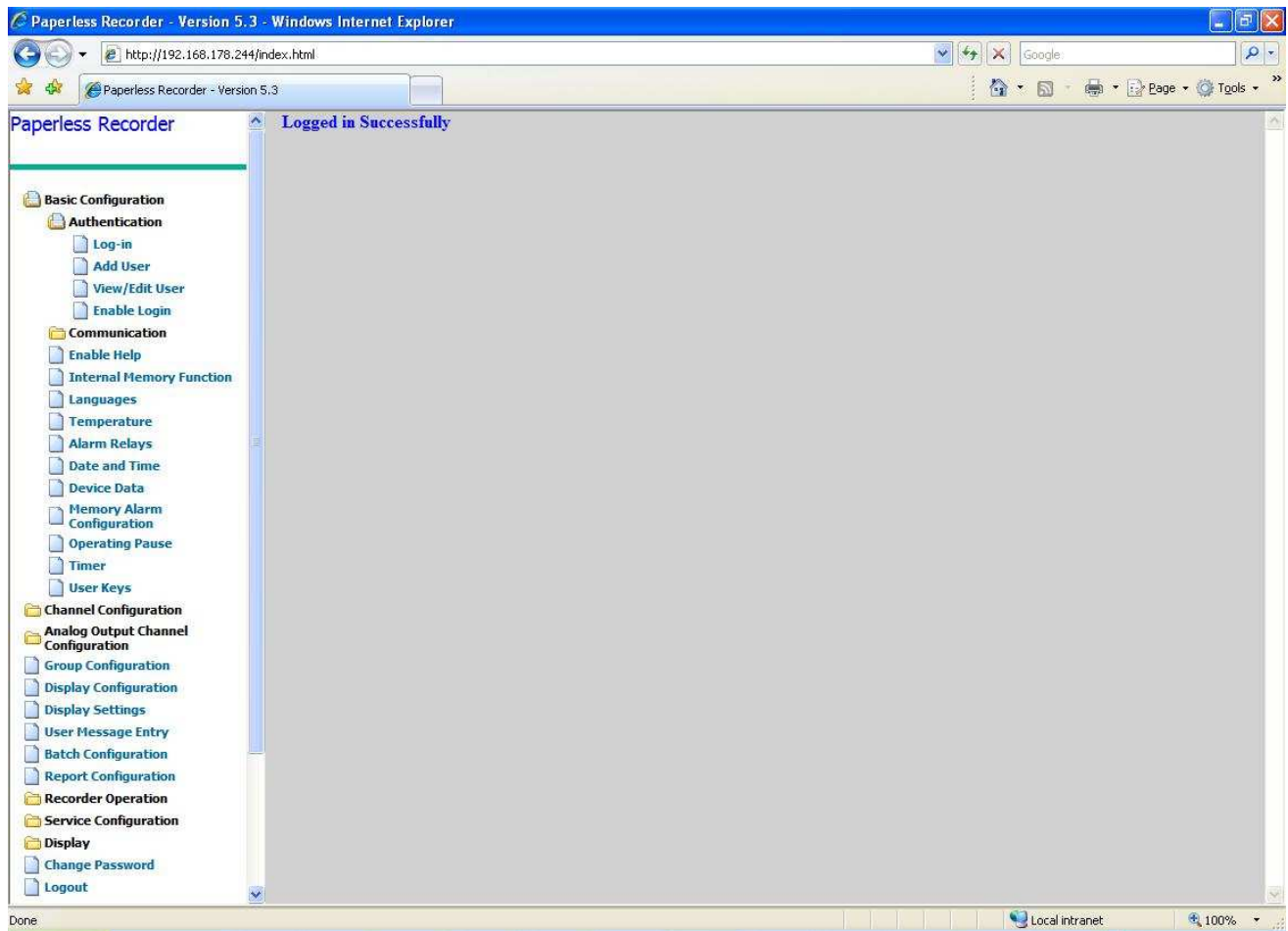

If the logged in user's password is expired then the following screen will be shown.

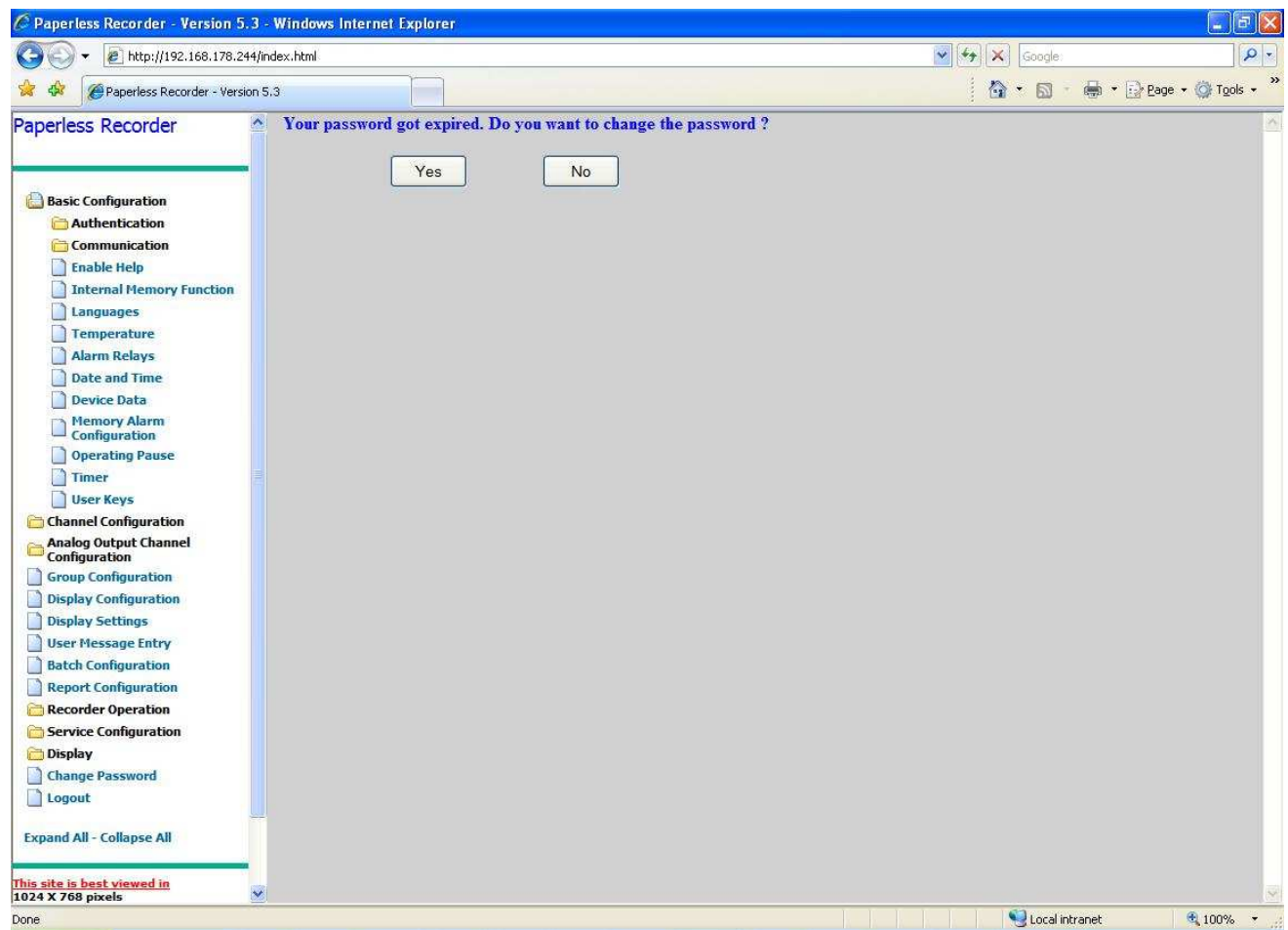

In the above page if the user presses *Yes* button then *Change password* screen will be opened and if the user presses *No* button then the following screen will be shown.



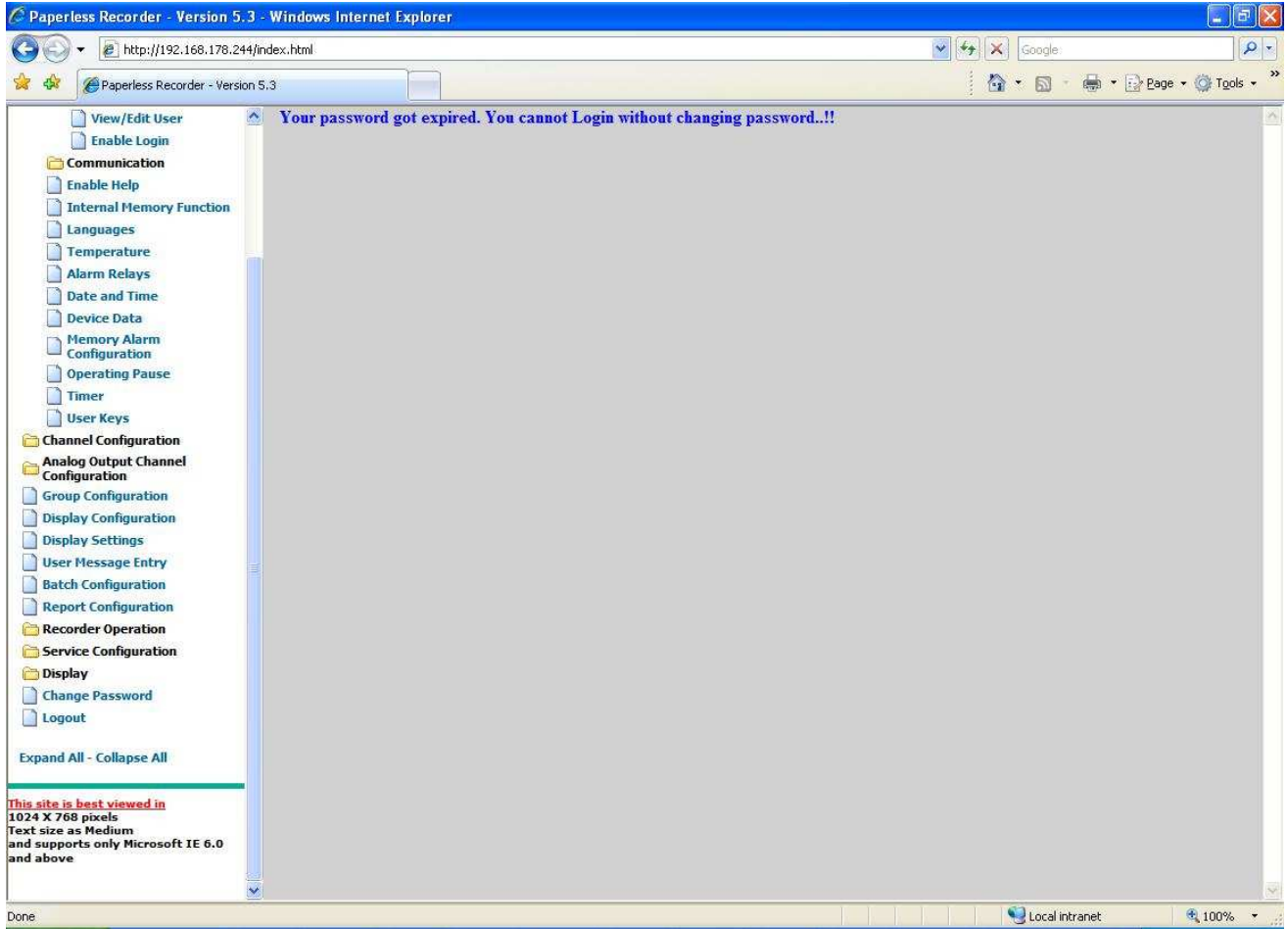

### 9.2.1.1.2 Add User

To add a user to the recorder, enter the user name and password. Then assign a Permission Level as shown in the following figure. The permissions allowed for each level is as shown below. 'Master' user and user with permission level 6 can only add users. In Username field only A to Z, a to z, 0 to 9 and \_ (under score) characters are allowed and in Password field all characters except +(plus) &(amperes and) ;(semicolon) characters are allowed.

Each user can be set to have its own password expiry period. The user password can be set to expire in,

- 3 Months,
- 6 Months,
- 9 Months and
- 12 Months

If user does not want to have any expiry period can select *No expiry* option.

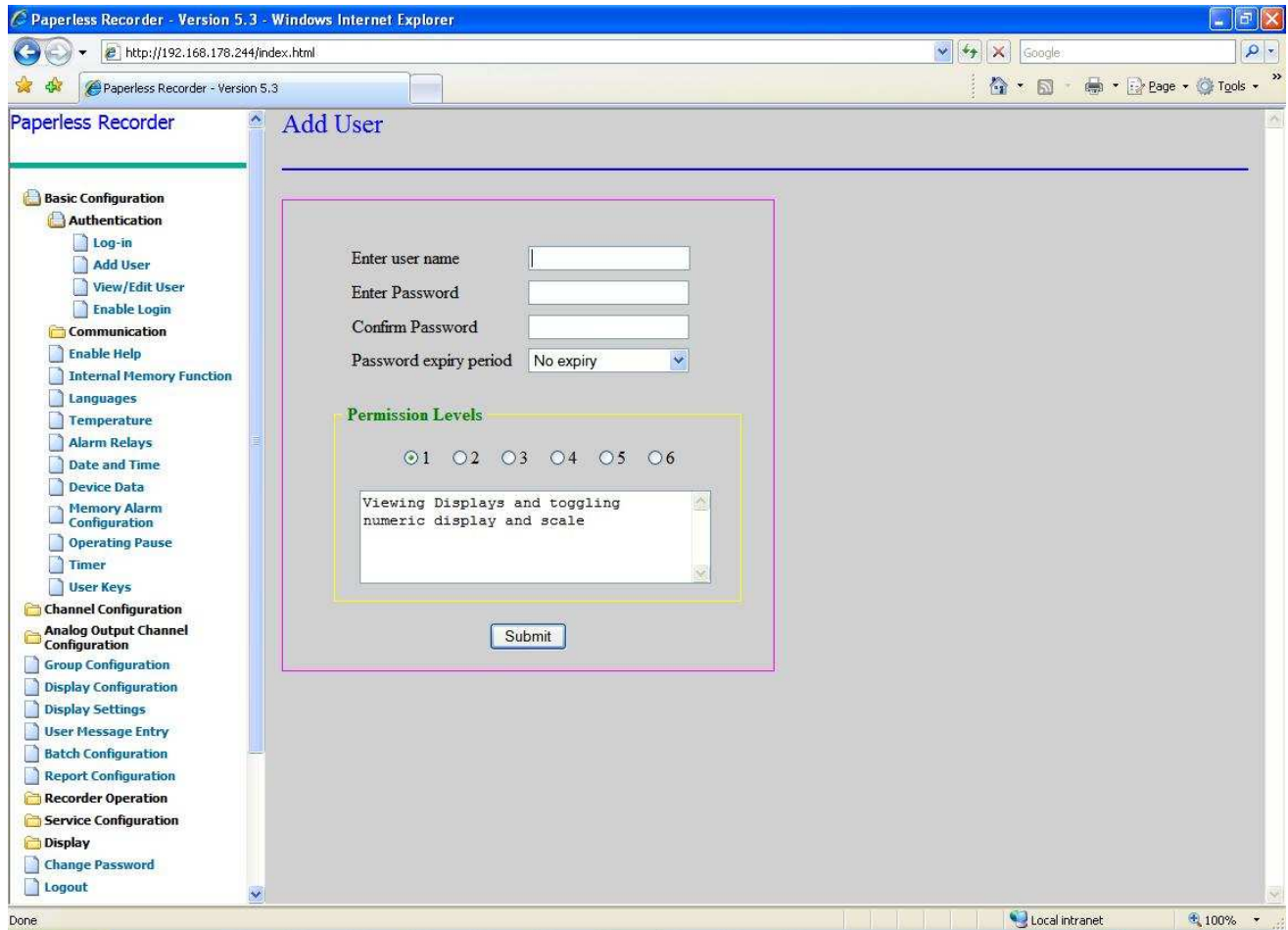

Figure 9. 8: Add User

User's permissions are as follows:

**Level 1: Viewing Displays and toggling numeric display and scale:** This option allows you to view the groups and combination views, historic groups, historic and live batches, report files, logs, measurement overview. You can also use the user keys: - Hide/Disp Numeric Display and Hide/Disp Scale.

**Level 2: Viewing all menus and Operation:** This option allows you to view all the settings and live graphs except the authentication menu. Also you can use the Recorder operation menu to start/stop the recording and operations like *Reset calculation*, *Reset counter input*, *Screenshot*.

**Level 3: Viewing all menus, Operation and Data Read Out:** For browser application it is same as Level 2.

**Level 4: Viewing all menus, Operation, Data read out and Configuring:** This option allows you to configure all the settings. You cannot add, delete the user of the recorder.

Level 5: Viewing all menus, Operation, Data Read Out, Configuring and Delete Files: For browser application it is same as Level 4.

Level 6: Viewing all menus, Operation, Data Read Out, Configuring, Delete Files and Firmware Download: This option allows you to configure all the settings except enabling/disabling login option. You can add, delete the user of the recorder.

**Note: The recorder can have a maximum of 12 users including the Master user.**

### 9.2.1.1.3 View/Edit User

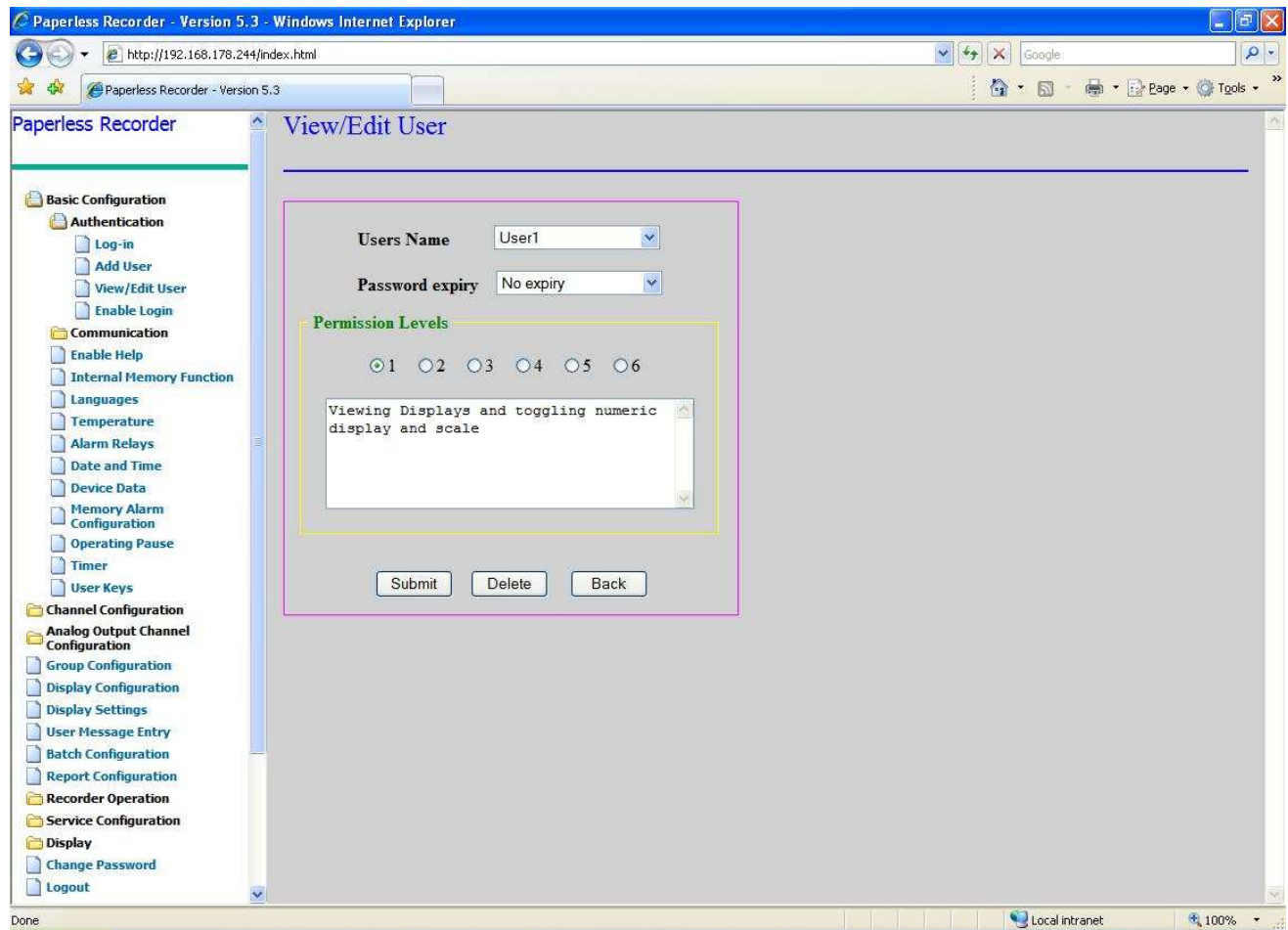

Figure 9. 9: View User

The view user option allows you to view the details of the users that have access to the recorder. Using this option you can also delete users. Once this option has been selected the screen will be as shown above. You have to select a user from the list of users provided by the field 'Users Name'. Once a user is selected the permissions assigned to that user will be displayed in a box and can be edited. Only the master or a user with permission level 6 may edit the details of a

user. To save the changes made click on the “*Submit*” button. To delete a user, you have to select a user from the list of users provided by the ‘Users Name’ field and then click on the ‘Delete’ button. For users with permission level 1 to 5 this page is not accessible.

The View/Edit user option allows editing the user permission level and the password expiry period of the user. Only *Master* will be authorized to edit its own expiry period.

**Note: No one can delete or change the permission of the Master.**

#### 9.2.1.1.4 Enable Login

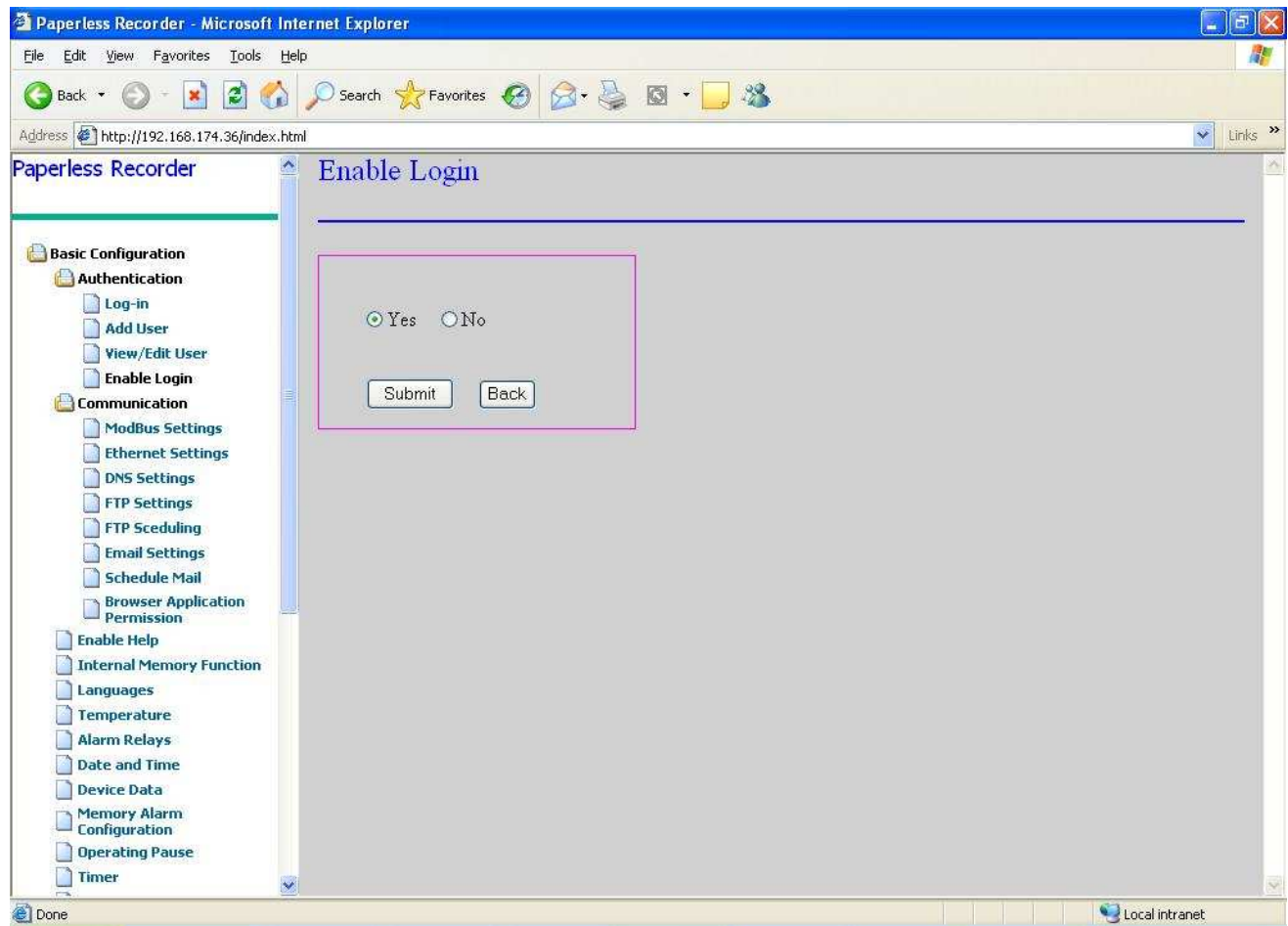

Figure 9. 10: Enable Login

The ‘*Enable login*’ option allows you to enable the login process. If “Yes” is selected, the login option is enabled and vice versa. If ‘Enable Login’ is disabled, the authentication of user via login is disabled. The *Master* can only enable this. And in this case, you will be prompted to login by providing a password. After the password has been accepted, ‘Enable Login’ will be enabled. Without logging in if one tries to access the browser when the enable login is activated, one will be

prompted to Login each time a link is clicked. If login is disabled the browser accessing user will be treated as security level 6 users.

**Note:** By default Enable login is disabled.

### 9.2.1.2 Communication Menu

This option in the menu allows the user to set the *MODBUS*, *Ethernet*, *DNS*, *FTP* and *Email Settings*. It also provides the options for *Scheduling e-mails* and *FTP Uploads*. The option for setting the *Browser application permissions* is also present in this sub-menu.

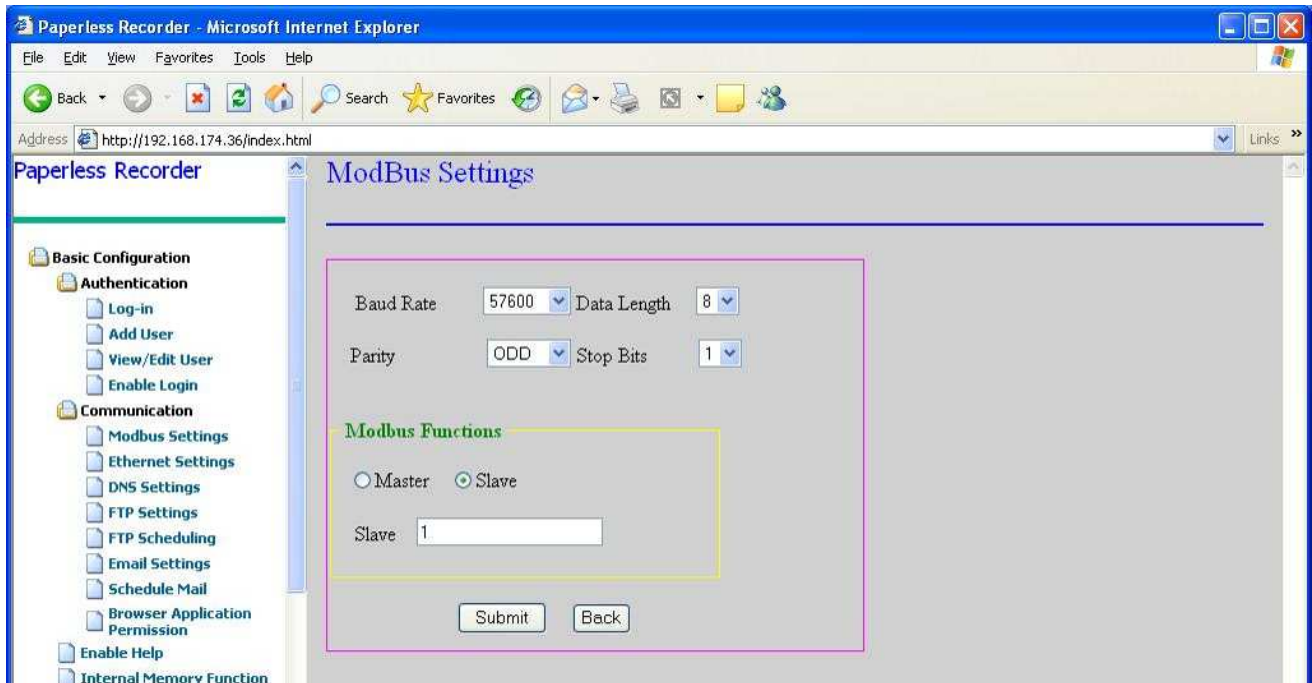

Figure 9. 11: Communication Menu

#### 9.2.1.2.1 MODBUS Settings

You may configure the *MODBUS* by specifying the Baud rate, parity, data length, stop bits and mode of *MODBUS* operation i.e., Master or Slave. If you select the master option the textbox to enter the slave address will be disabled. If you select the slave option then the user will have to enter the slave address in this box. For more details see the Recorder side *MODBUS setting*.

**Note:** Every time the *MODBUS Settings* are changed, the data acquisition process in the recorder will be reset.

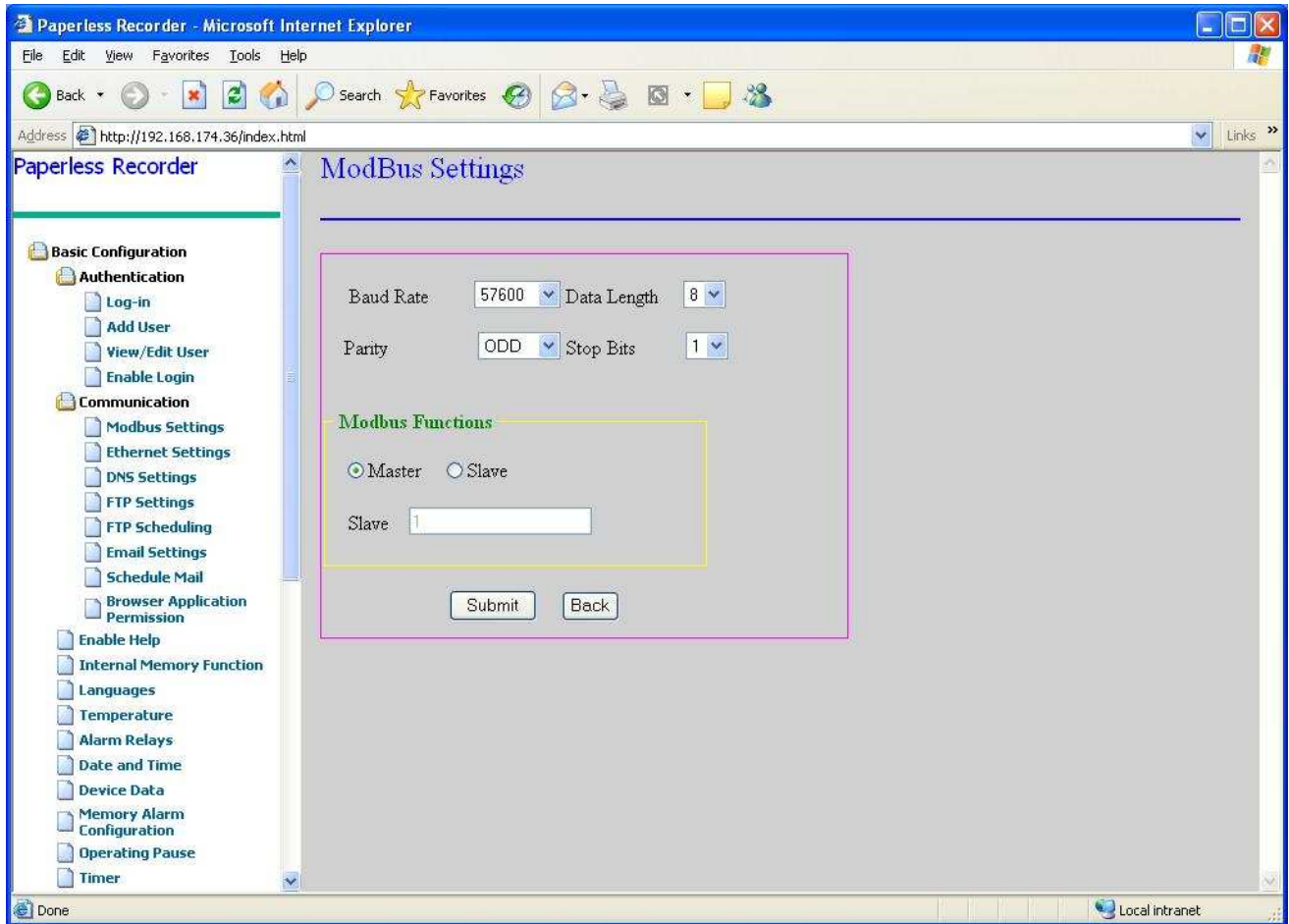

Figure 9. 12: MODBUS Setting

### 9.2.1.2.2 Ethernet Settings

The 'Ethernet settings' have to be entered in order to use the Ethernet communication functionality of the recorder. The setting can be done via DHCP Server or they can be entered directly by selecting the 'Static IP Address' option. After successfully changing the IP address of the recorder you have to close the current browser window and reopen the site with new IP address.

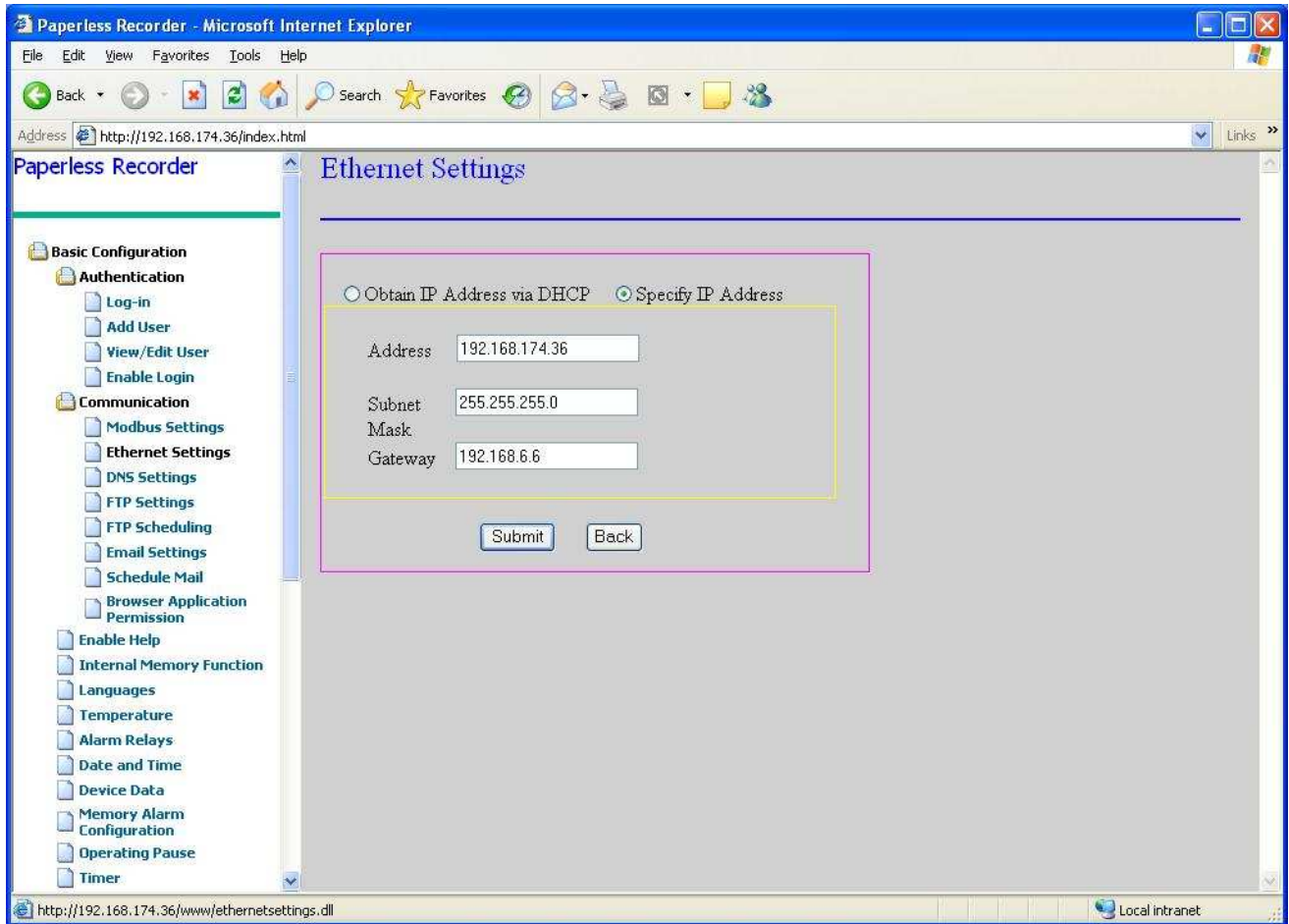

Figure 9. 13: Ethernet Setting

The entries to be made are: -

#### IP Address

- Enter the IP Address that is to be assigned to the recorder.
- The address is a 32-bit value normally expressed with four values, each separated by a period (e.g. 192.168.33.121).
- Each of these values can take any value from 0 to 255.
- This IP address will be used to distinguish between the various devices connected to the Internet, while using TCP/IP protocol for communication.

#### Subnet Mask

- Subnet mask is used to determine the network address from the IP address.
- Set this value according to the system or the network to which the recorder belongs.

### Default Gateway

- Set the IP address of the gateway that will be used for communicating with the other networks.
- Set the value according to the system or the network to which the recorder belongs.

**Note: If the correct IP Address has not been set for the device, then the Browser Application Module will not work.**

### 9.2.1.2.3 DNS Setting

You may set the DNS server settings using this option as shown in the screen below. The primary and secondary DNS server address (secondary address is optional), the host name, domain name and both the primary and secondary domain suffixes have to be provided by the user. For more details see the Recorder side *DNS setting*.

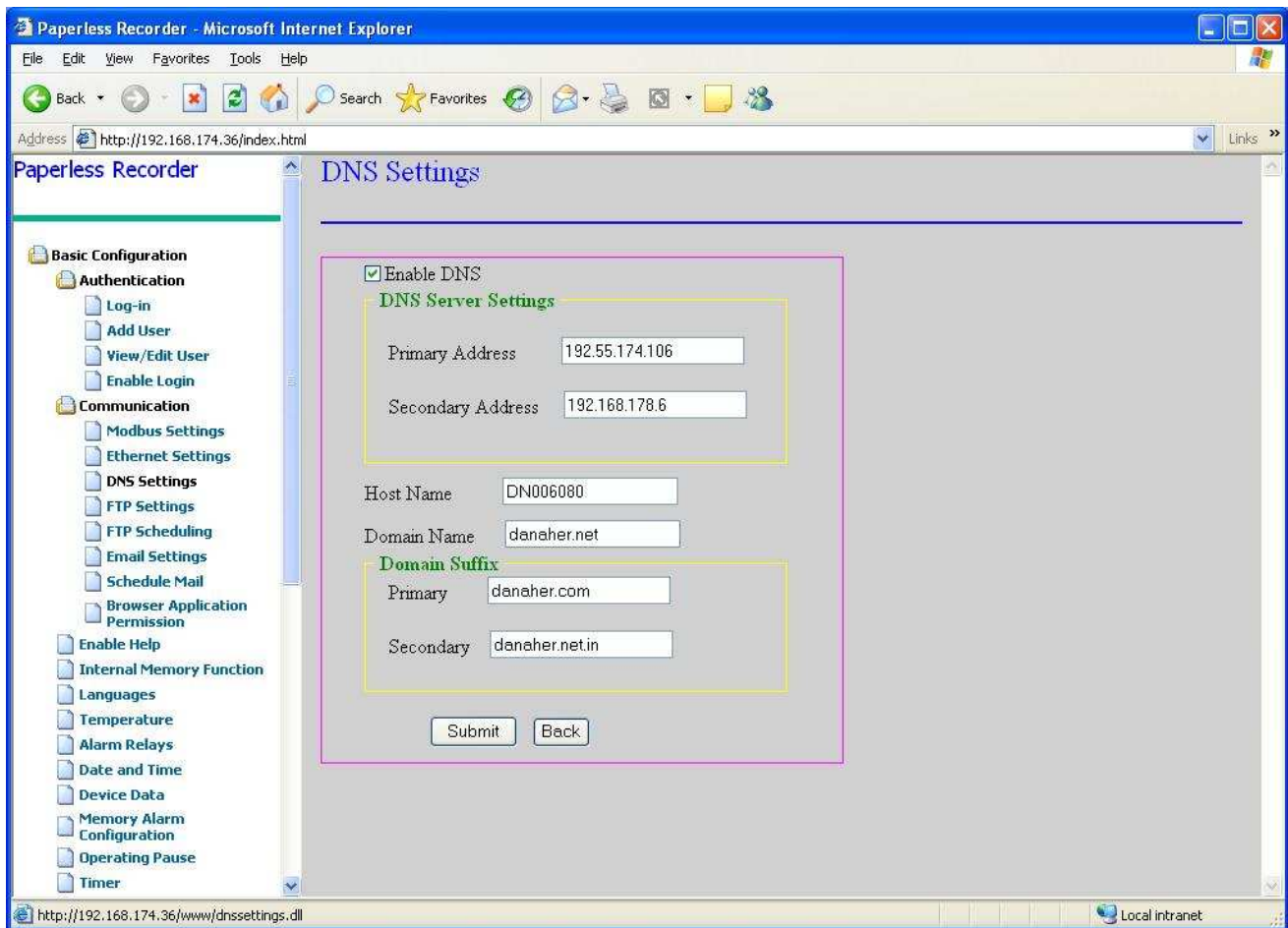

Figure 9. 14: DNS Setting



### 9.2.1.2.4 FTP Settings

You can set the FTP Server Address, login name, password and the home directory name using this option. The recorder will use these settings to connect to the FTP server, to upload files.

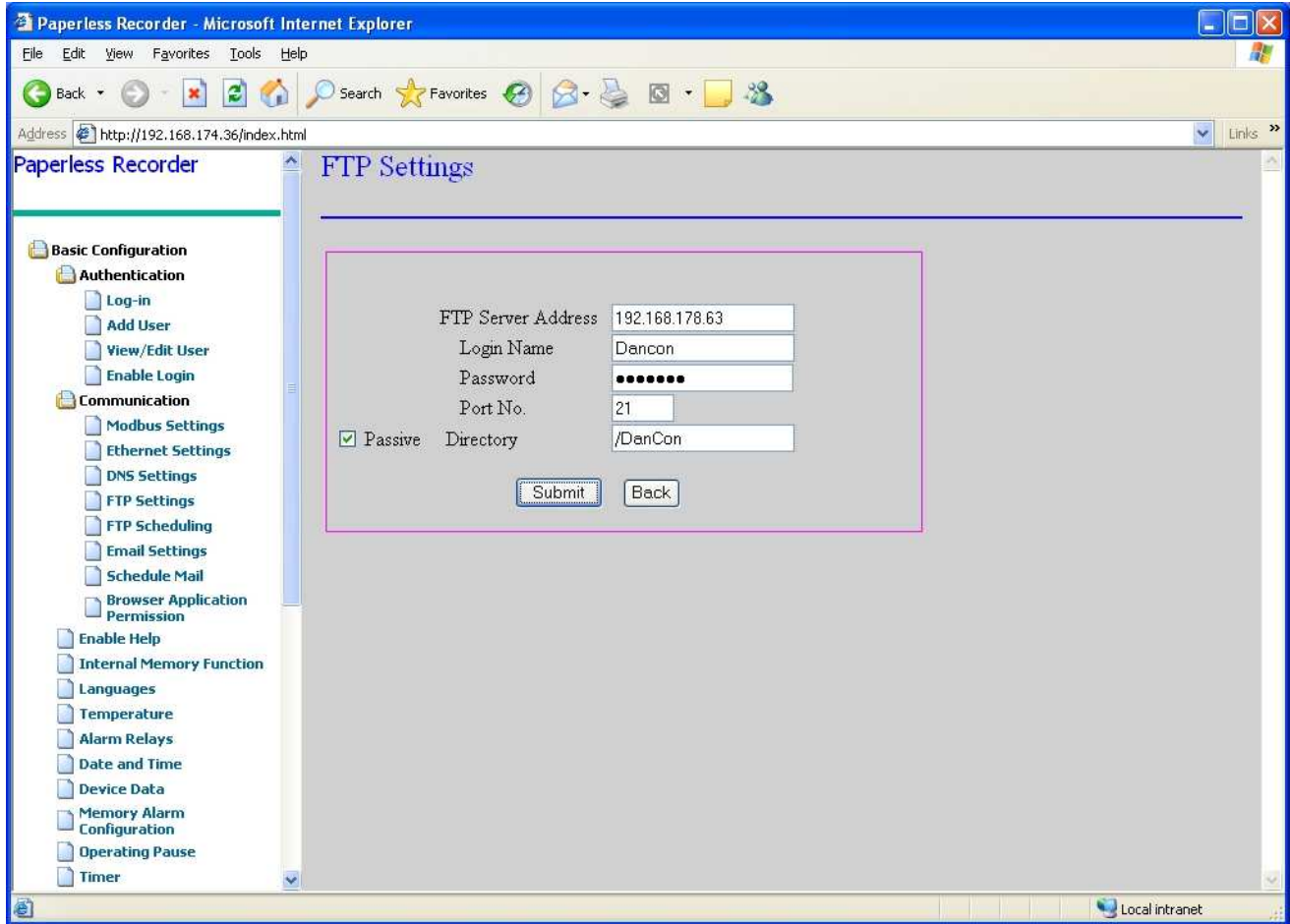

Figure 9. 15: FTP Setting

Enter the *FTP* Server address as shown in the above screen, followed by the Login name, password and port number; default value of port number is 21. Then you can select the mode of operation as passive (used incase of firewalls) if required. You may also enter the Directory name to upload the files to a particular directory in the server. If the directory specified by you, doesn't exist in the FTP Server, then the recorder will create it. For more details see the Recorder side *FTP setting*.

### 9.2.1.2.5 FTP Scheduling

You can schedule a file upload through FTP using this option. The files will be uploaded to the directory specified in the FTP server settings

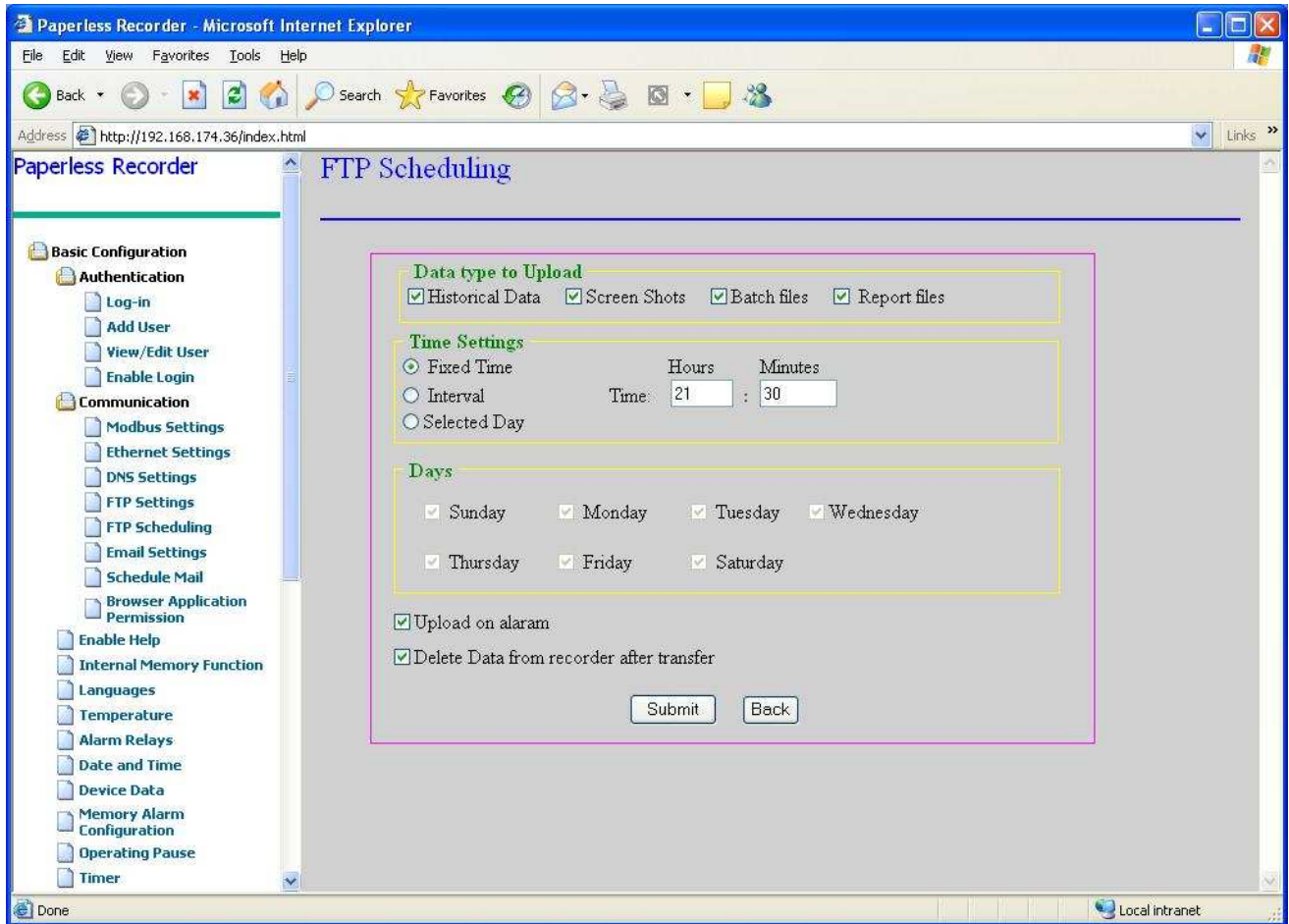

Figure 9. 16: FTP Scheduling

Here you can select the type of files to upload in schedule. The files present are Historic data, Screenshot files, Batch files and Report files.

You can schedule the *FTP* upload at '*Fixed Time*'. If a time value is specified in the time edit box, the upload shall be done every day at the specified time.

If scheduled as '*Interval*', the Upload will be done after the specified time interval, starting from the time the configuration was confirmed.

If scheduled as '*Selected Days*', the Upload shall be done on the selected weekdays at the time provided in the '*Time*' entry box.

If the "*Upload on alarm*" check box is selected, every time an alarm occurs, the files selected for upload will be uploaded. If the "*Delete data from recorder after transfer*" check box is selected, the files that have been successfully uploaded to the FTP Server will be deleted from the recorder.

For more details see the Recorder side *FTP Scheduling*.

### 9.2.1.2.6 Email Settings

This option allows you to set the SMTP server settings as show in the figure below. You have to specify the SMTP server address and the port number to be used for connecting to the mail server. Default port number is 25. You can also set a signature for the recorder. This signature will be attached to all the email sent by the recorder and is used to identify the emails sent by a recorder. The SMTP server authentication is not provided in this version of the recorder so the Account name, Password fields are permanently disabled. Also the log using secure connection (S.S.L.) is not provided in this version so it is permanently disabled. For more details see the Recorder side *Email Settings*.

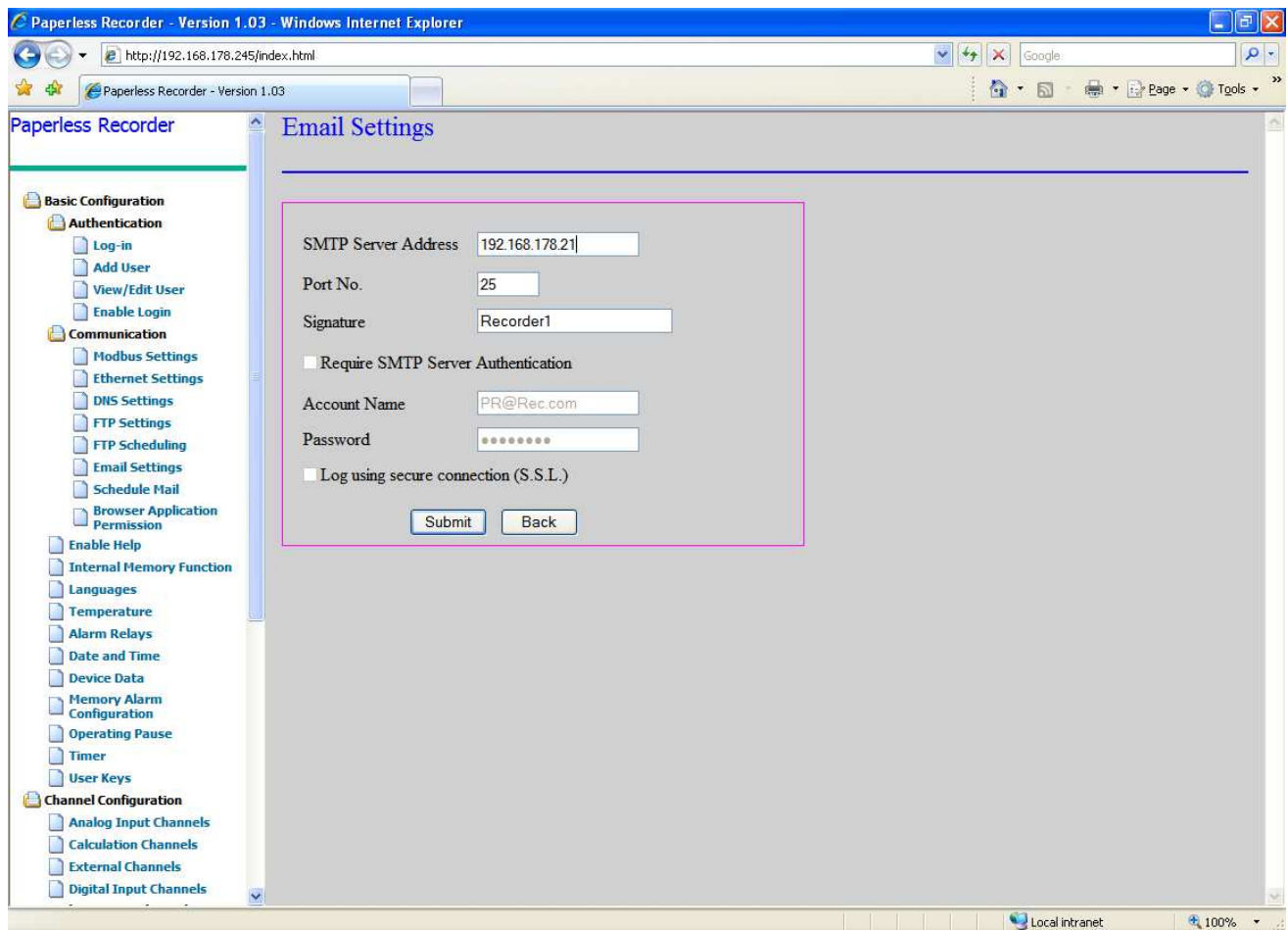

Figure 9. 17: E-mail Setting

### 9.2.1.2.7 Schedule Email

You may schedule emails so that email will be automatically sent to the required users with the required files. The emails can be scheduled as shown in the figure. You have to enter the email addresses to which the email is to be sent. Then you have to enter a subject followed by a message. Then specify the type of file to send like Historic file, Screen shot, Batch file or Report files. The file will automatically be attached to the email. You also have to enter the maximum size of the attachment for an email. Here maximum attachment is 6 MB. When sending mails, the recorder will ensure that the attachment file's size doesn't exceed the size specified in this field. A maximum of 10 files can be sent as an attachment with each email. This number also depends on the file size. If there are more than 10 files on recorder side and email is scheduled for "Fixed Time", "Interval" or "Selected Days", more than one mail will be sent to corresponding mail ID.

Figure 9. 18: E-mail Scheduling

The procedure for scheduling a mail is exactly the same as that of FTP Transfer.

The user can schedule the email at a 'Fixed Time', if a time value is specified in the Time: 'hours and minutes' edit box.

If scheduled as *'Interval'*, the email will be sent after the specified time interval, starting from the time the configuration was confirmed.

If scheduled as *'Selected Days'* the email will be sent on the selected weekdays at time provided in the *'Time'* entry box.

If the *"Email on Alarm"* check box is selected, every time an alarm occurs, email will be sent along with the data files, which were selected in the previous screen. If the *"Delete data from recorder after transfer"* check box is selected, then the files that have been successfully sent as attachments with emails will be deleted from the recorder. For more details see the Recorder side *Schedule Mail*.

### 9.2.1.2.8 Browser Application Permissions

This option in the communication allows you to enable/disable various *'Browser Application Permissions'* options as shown in the below figure. You may enable viewing of measurement values; historic data and recorder operation via HTML (Browser application) you may also enable/disable configuration of the recorder via Browser application. When none of the options are selected the user will not be having the deselected permissions and the message "You are not authorized to change" would be displayed on each of the pages, and the submit button will also be disabled. For changing the settings one needs to make changes on the recorder side.

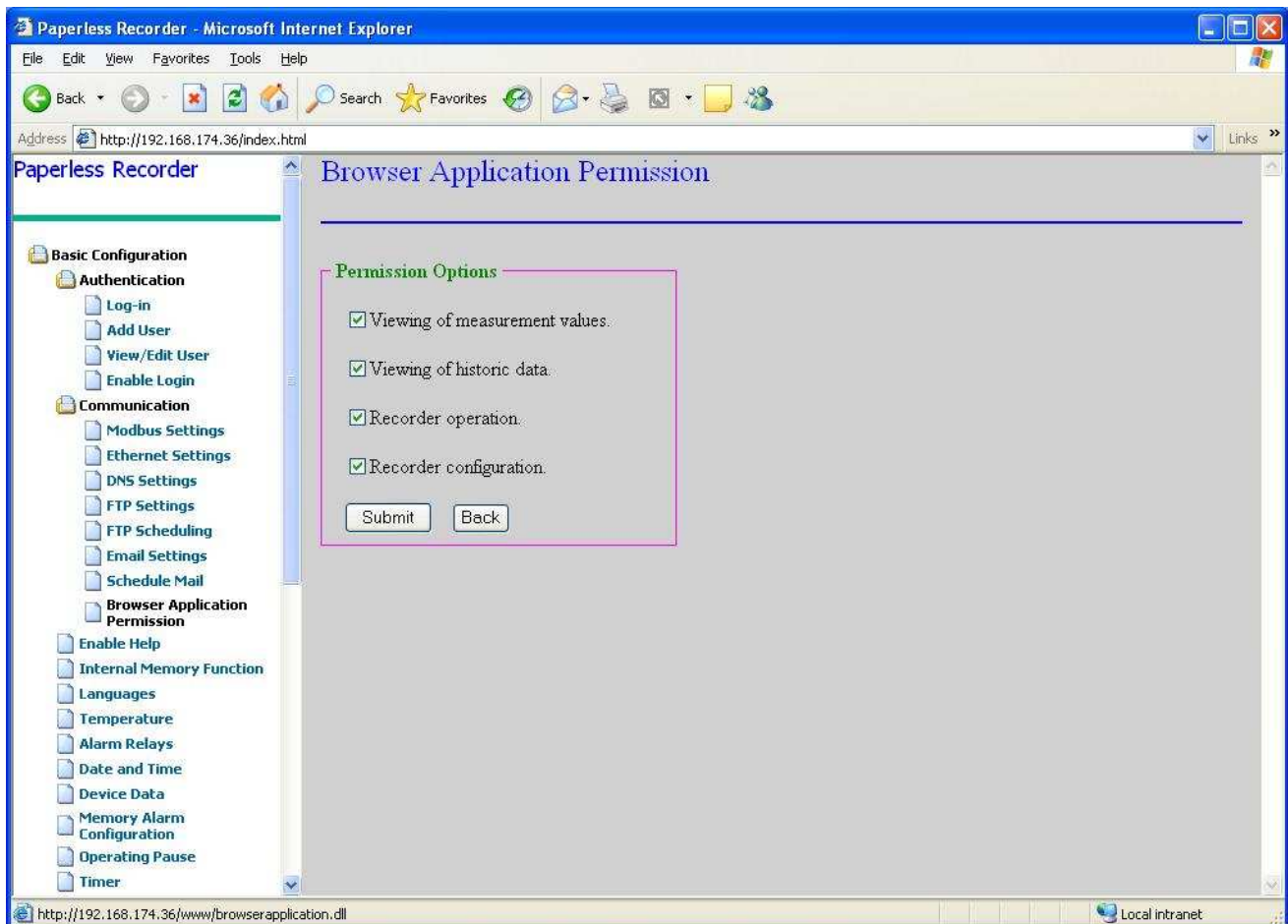

Figure 9. 19: Browser Application Permissions

### 9.2.1.3 Enable Help

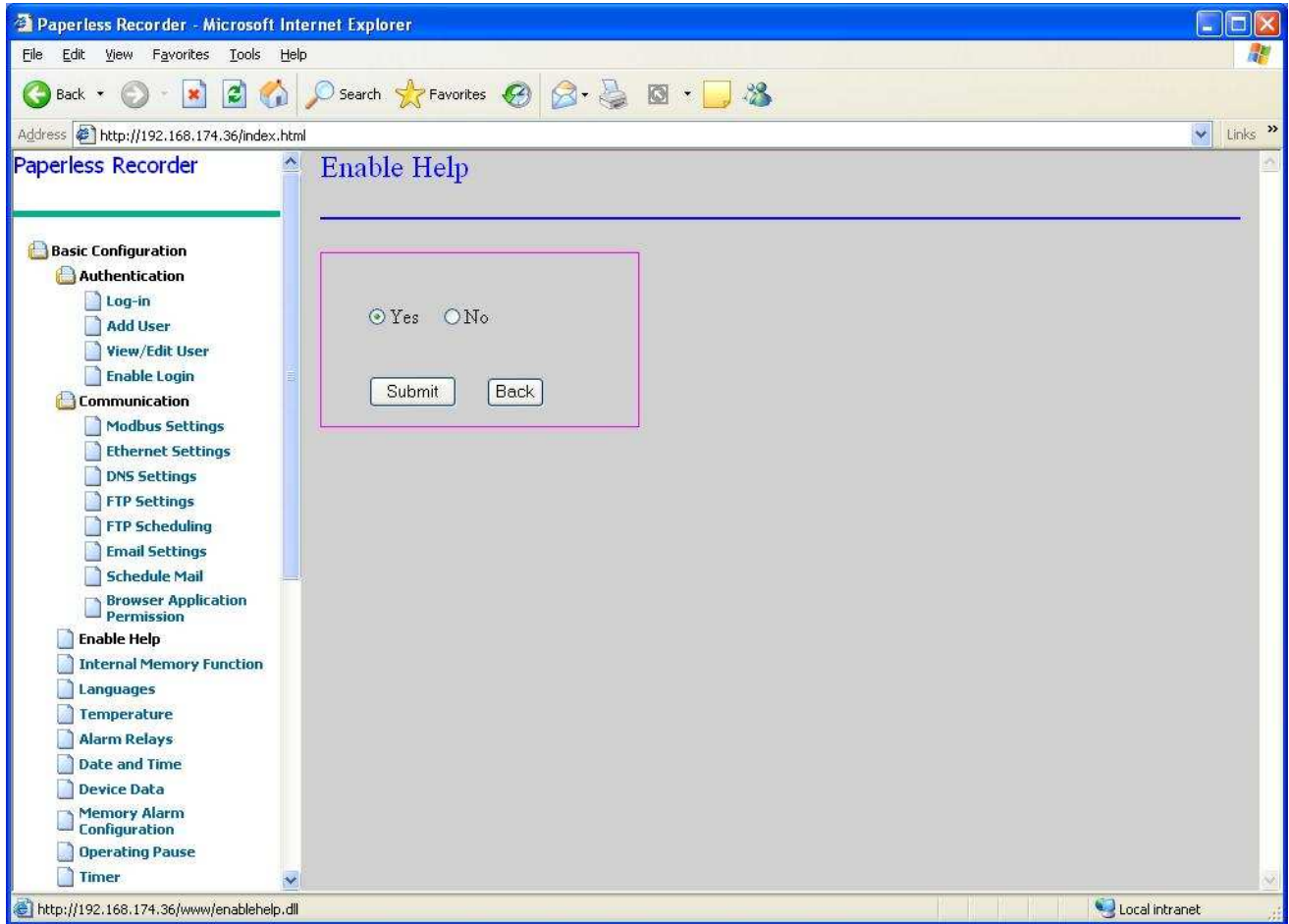

Figure 9. 20: Enable Help

This option allows you to enable/disable the Help Function of the recorder.

### 9.2.1.4 Internal Memory Function

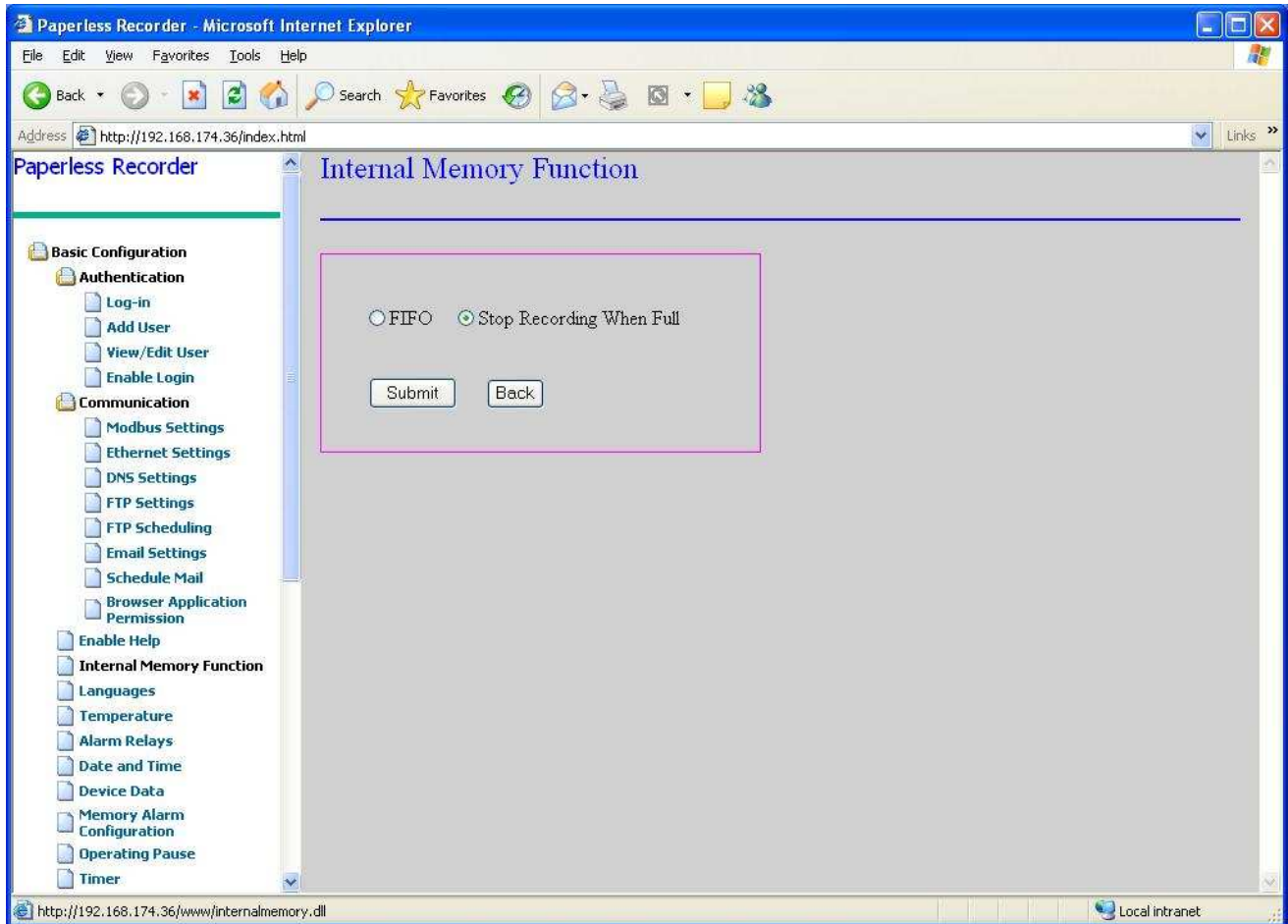

Figure 9. 21: Internal Memory Function

This option of the Basic Configuration allows the user to configure the memory as *FIFO* (First In First Out) or *Stop recording when full*. For more details see the Recorder side *Internal Memory Function*.

### 9.2.1.5 Languages

The required language can be selected from the option listed. The available languages are English, French, Spanish and German. This version of the recorder supports only English language so other languages are disabled.

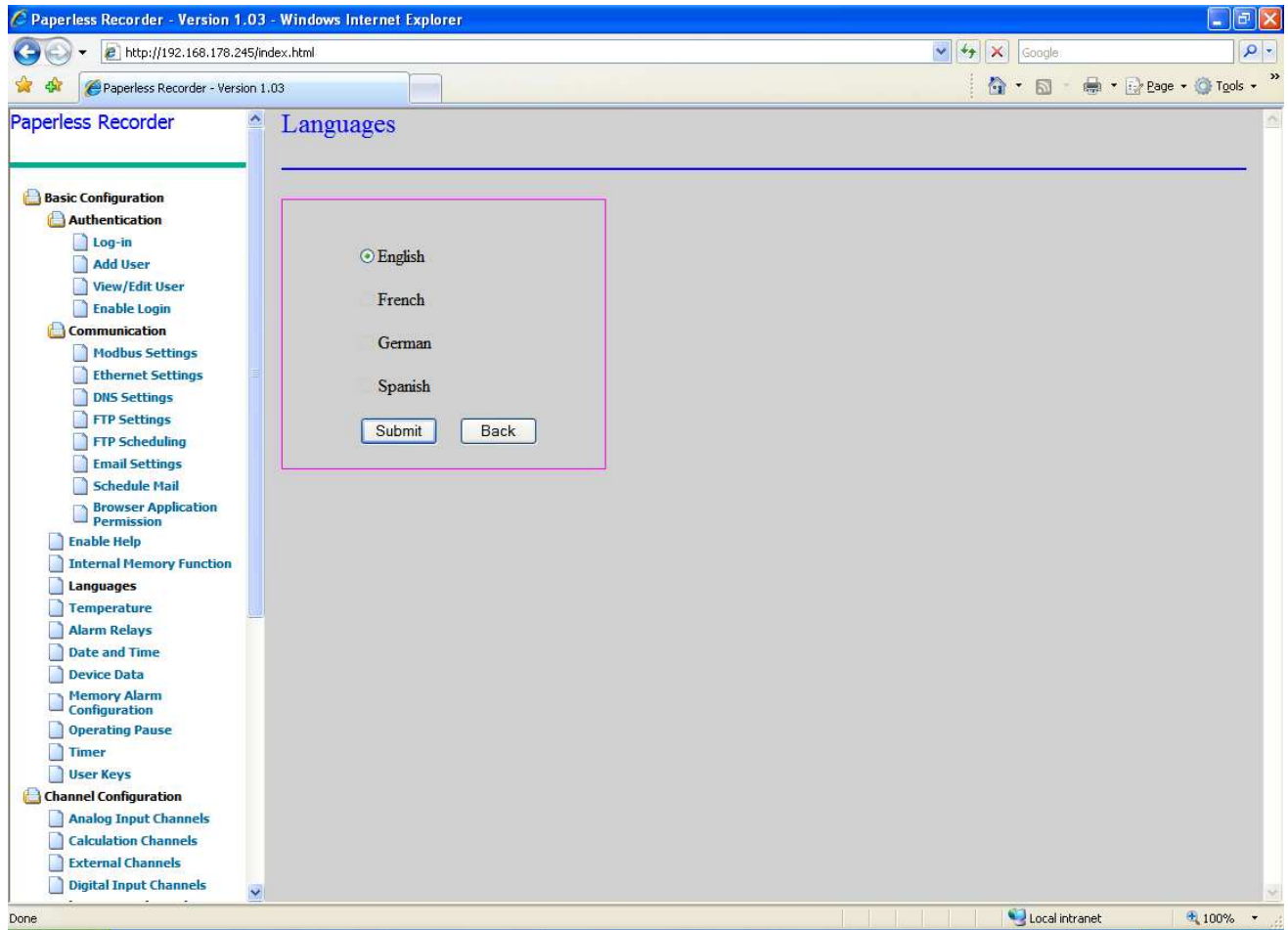

Figure 9. 22: Languages

### 9.2.1.6 Temperature

The unit of temperature can be selected by choosing one of the options provided i.e. Celsius or Fahrenheit. Once an option is selected, the selected unit of Temperature is applicable for only those On-Board input channels, which are configured as TC types or RTD types. For more details see the Recorder side *Temperature*.

Note: After changing the temperature from Celsius to Fahrenheit or vice versa all graphs will reset.



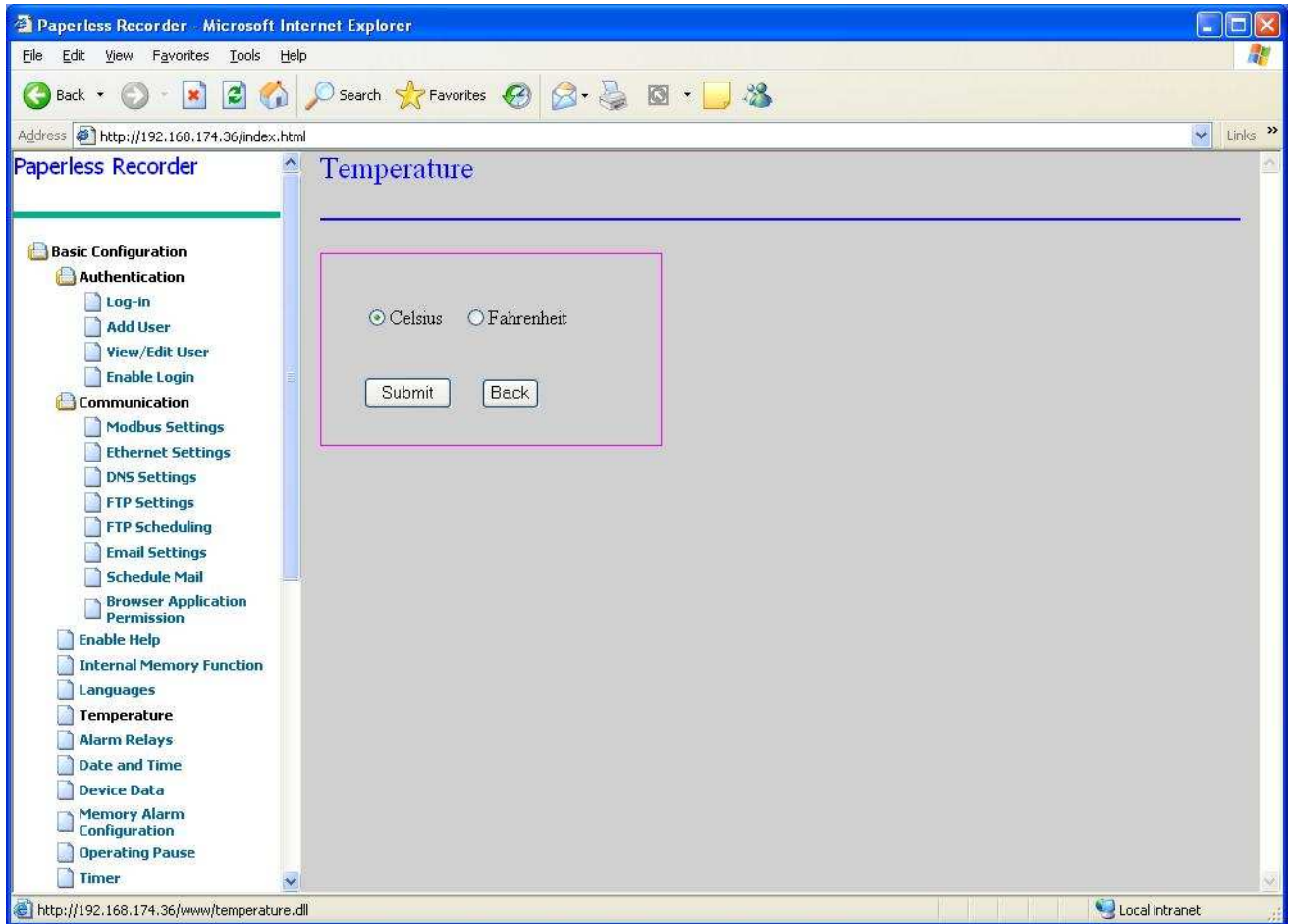

Figure 9. 23: Temperature

### 9.2.1.7 Alarm Relays

A channel with any of four alarms may be associated with an output relay. The number of output relays available with the Recorder depends on the number of output cards installed in it. An Output card can support four/eight or twelve Output Relays. If four relays are present in system then only the first four-relay information is enabled others will be disabled. A maximum of one output card is allowed in a recorder. The 'Alarm Relays', is used to configure the response of a relay, according to its associated channel alarm.

The response of a relay may be configured as 'Energize' or 'De-Energize'. If a relay is configured as 'Energize' it turns "ON" with the Alarm and vice-versa.

If configured as 'NonLatch' and 'repeat', the relay keeps toggling every 1 second during the alarm state, then goes to its "ON" or "OFF" state, depending on whether it's set as 'Energize' or 'De-Energize'.

If 'NonLatch' and 'non-repeat' ('repeat' option is not checked), it gives a single pulse of 1 second at the start of an alarm, and becomes ON or OFF, depending on whether its 'Energize' or 'De-Energize'.

If latch option is selected the repeat/Non repeat options get disabled.

For more details see the Recorder side *Alarm Relays*.

Note: Every time the Relays configuration is changed the data acquisition process will reset.

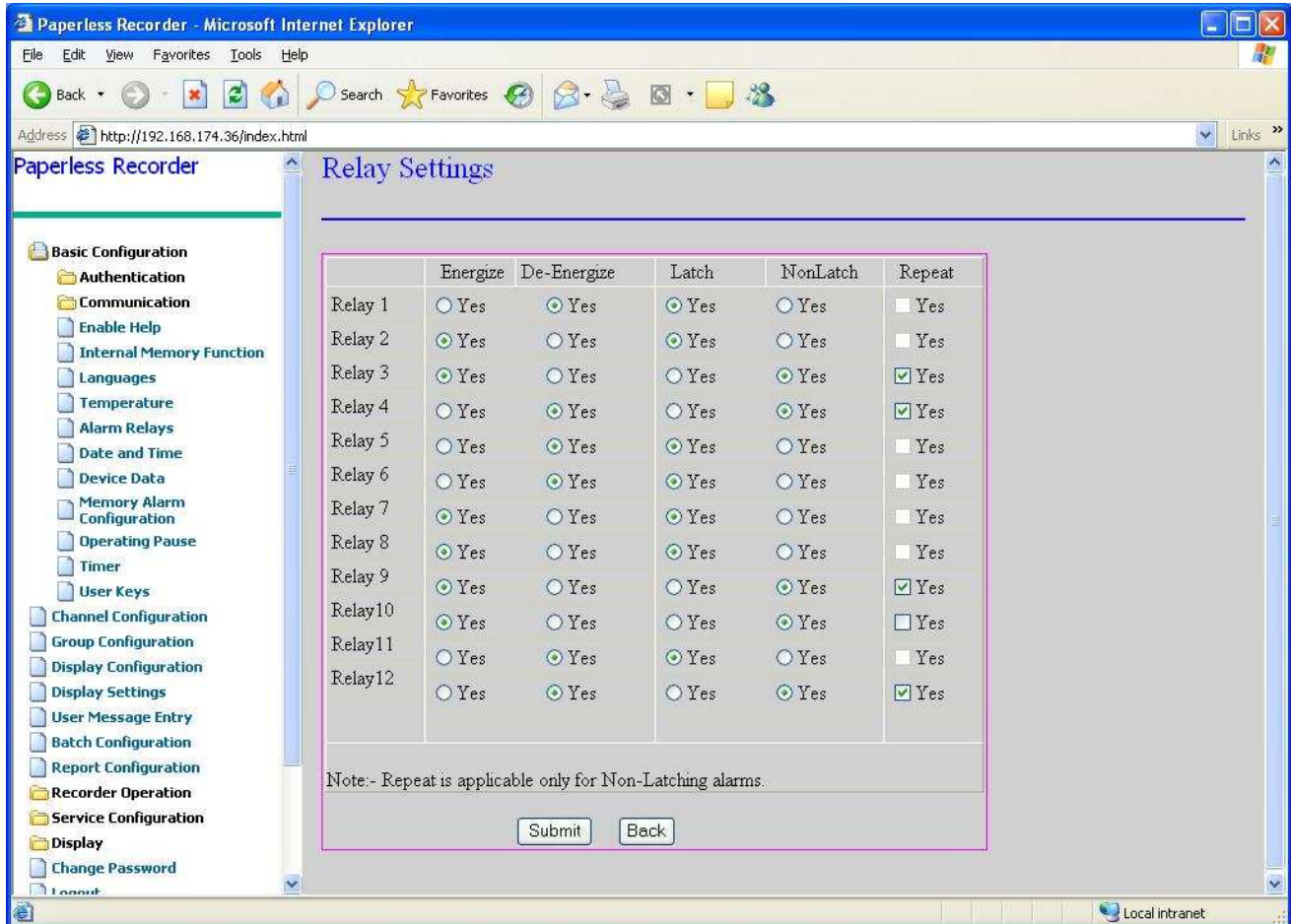

Figure 9. 24: Alarm Relays

### 9.2.1.8 Date and Time

The 'Date and Time' option of the 'Basic Configuration' allows you to set the time and date of the recorder. You have to enter the date as per the selected date format i.e. if you select dd-mm-yyyy then you have to enter in the first edit box the day, in the second the month and in the third the year in four digits. The time in HH:MM:SS (24 hours clock). You may also select the

display format for the date. The time of the recorder can also be set through timeserver by specifying the IP Address and port number of the timeserver. The default port number for the timeserver is 123. Also you have to select the time zone to adjust the time received from the timeserver. To set daylight savings you have to first enable daylight saving and then specify the summer start date (i.e. Last Monday of July) and the winter end date (i.e. First Sunday of January). You may also specify the time at which the change needs to be made. For more details see the Recorder side *Date and Time*.

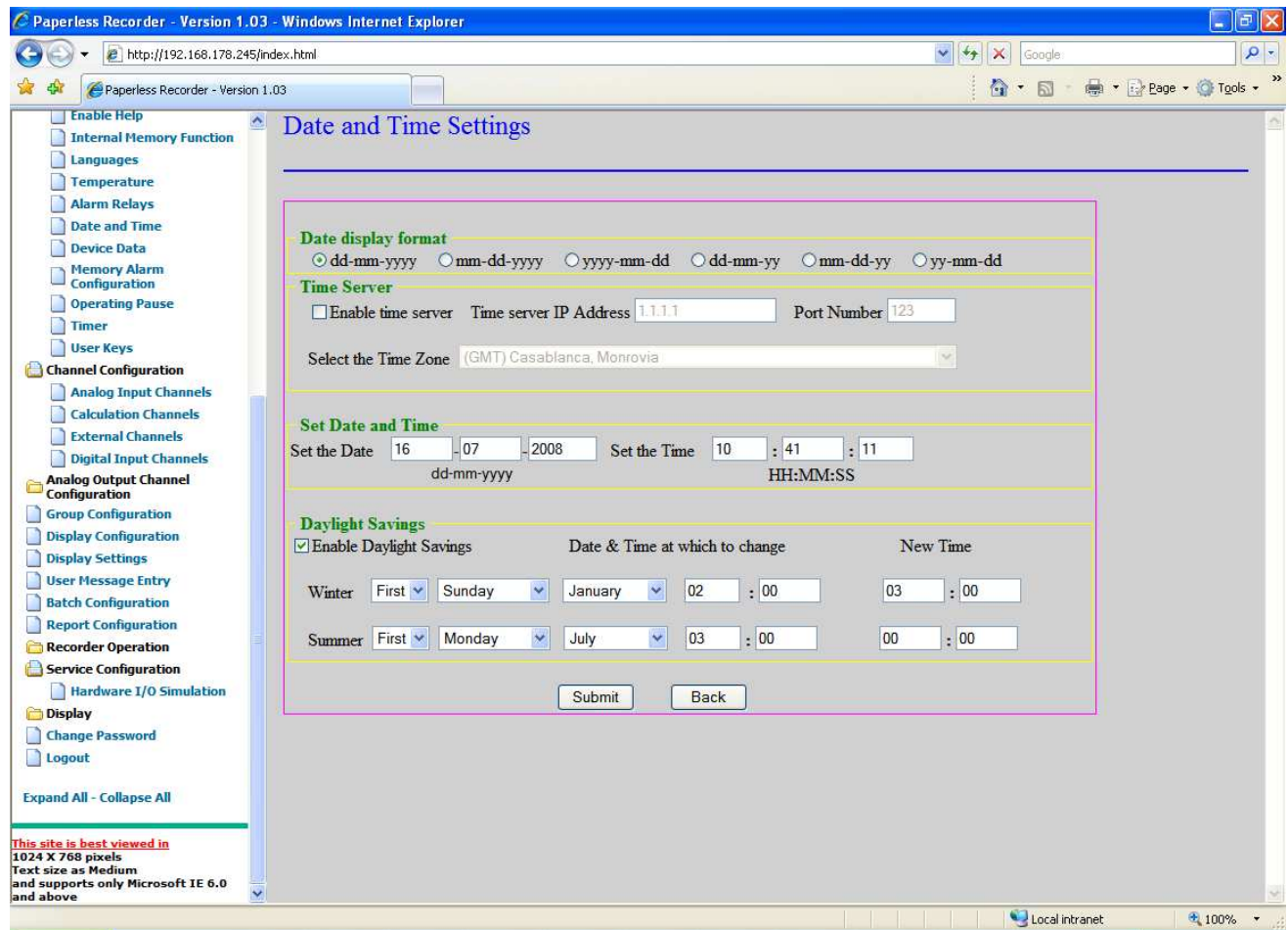

Figure 9. 25: Date and Time

### 9.2.1.9 Device Data

By selecting 'Device Data' option from the *Basic configuration menu*, the page shall be displayed as shown in the below figure 9.27.

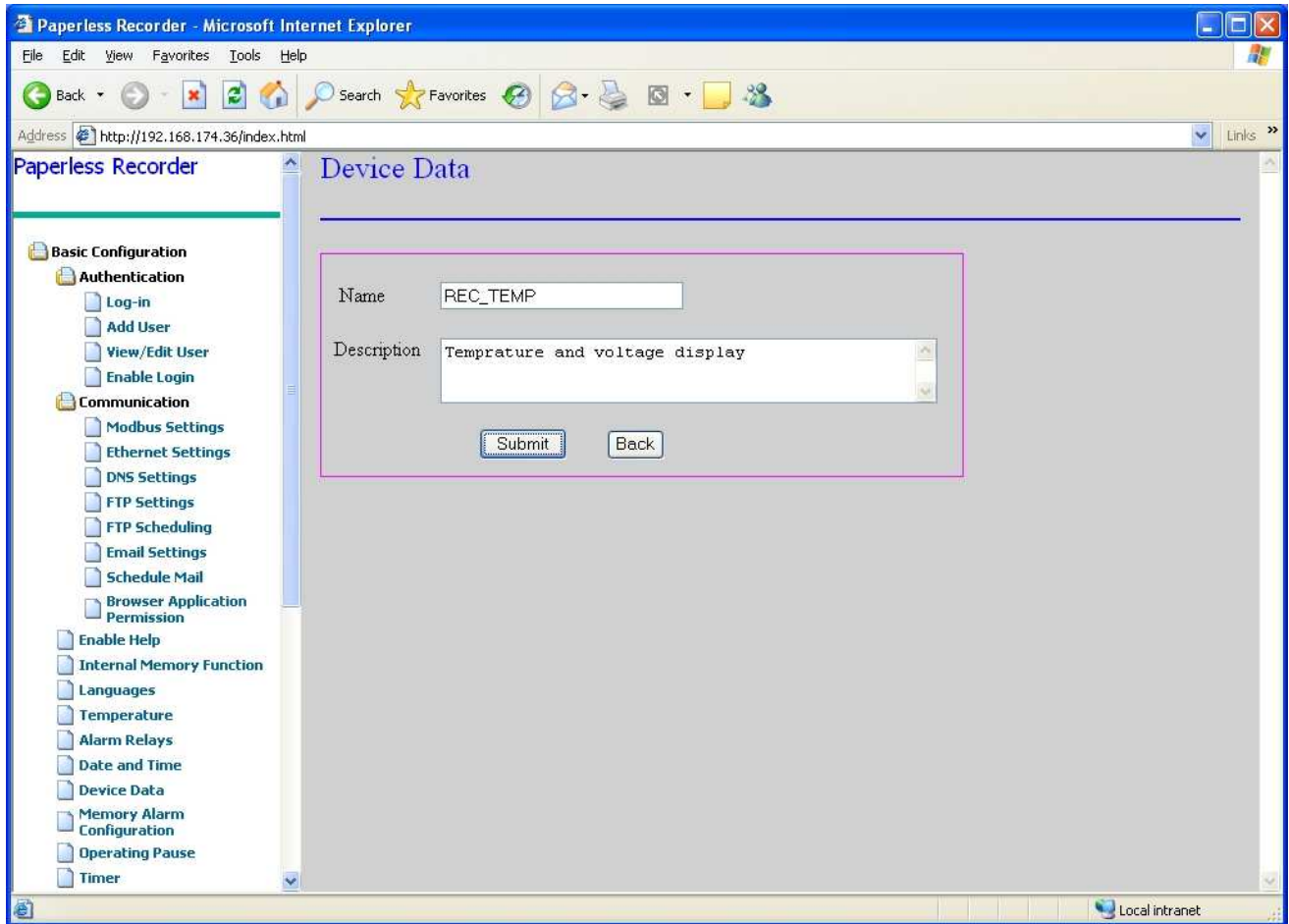

Figure 9. 26: Device Data

You have to enter the Recorder's name (maximum 16 characters) and Description (maximum 64 characters). Recorder's name is displayed on the left corner of the top status bar of the device. It is also used in the screen shot file names.

### 9.2.1.10 Memory Alarm Configuration

This option of the '*Basic Configuration*' menu allows you to set the unit of memory time (memory time is used to indicate for how long the remaining unused space in the storage device is sufficient to store data.) in days or hours. You may also use to configure memory related alarms. If day's option is selected then the remaining memory time is calculated in terms of days. If hour's option is selected then the remaining memory time is calculated in terms of hours. The alarm is triggered when the remaining memory time is less than or equal to the entered number of days/hours. Memory alarm start and stop are logged in the Alarm Log file. For more details see the Recorder side *Memory Alarm Configuration*. On disabling the Relay check box the Relay selection combo box gets disabled. If the Relay check box is enabled then if a set of relay is available with your recorder (a relay card with four, eight or twelve output relays must be installed), any one of the available relays can be associated to be activated whenever memory alarm is triggered.

**Relay:** On disabling the Relay check box the Relay selection combo box gets disabled. If the Relay check box is enabled then if a set of relay is available with your recorder (a relay card with four, eight or twelve output relays must be installed), any one of the available relays can be associated to be activated whenever memory alarm is triggered.

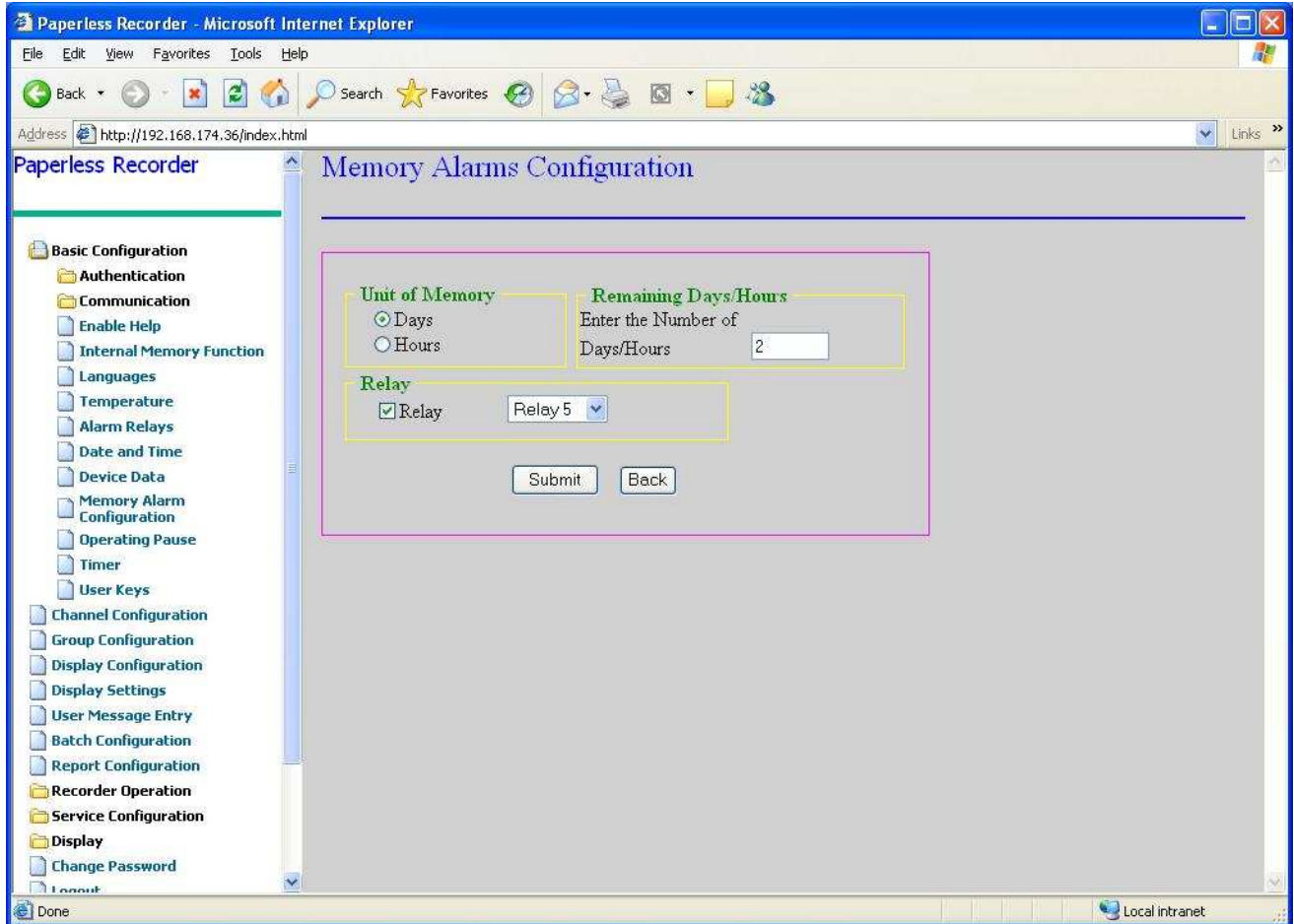

Figure 9. 27: Memory Alarm Configuration

### 9.2.1.11 Operating Pause

You may specify the time for which the recorder must remain idle before automatically switching the screen back to the group display. In the figure below the screen is configured to automatically switch to group display if the recorder has been idle for 90 seconds. Once you try to use the recorder after the specified operating pause, you will have to login again, if both 'Automatic logout' and 'Enable login' (Explained in Basic Configuration->Authentication) are enabled. For more details see the Recorder side *Operating Pause*. Operating Pause is applicable if and only if a user has logged in.

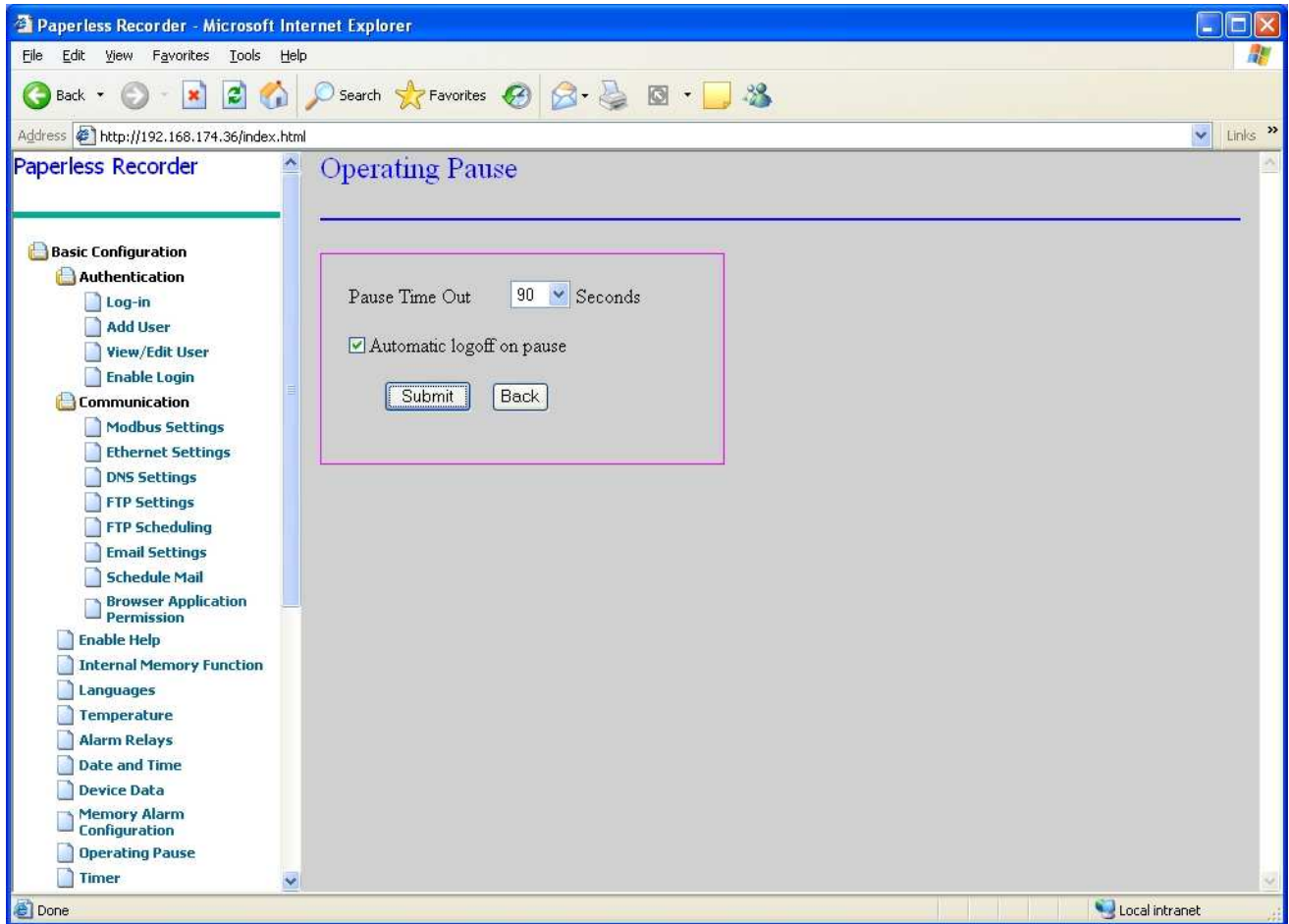

Figure 9. 28: Operating Pause

### 9.2.1.12 Timer

This option in the *Basic Configuration* allows you to configure the four timers provided as shown in the figure. You may select any of the four timers and also specify the time interval for it. Here the Timer 2 will reset after every 2:00 (after every two hours thirty minutes.). The timer may be selected as ‘*Absolute*’ or ‘*Relative*’. In case it is made *absolute*, then you have to specify the start time as well as the time interval. In the case of *relative*, you have to specify the time interval. The relative timer is started when the calculation is started. To save settings click on “Submit”. Set the time interval to 00:00 to disable a particular timer. For more details see the Recorder side *Timer*.

Note: Every time the timer configuration is changed the data acquisition process will be reset.

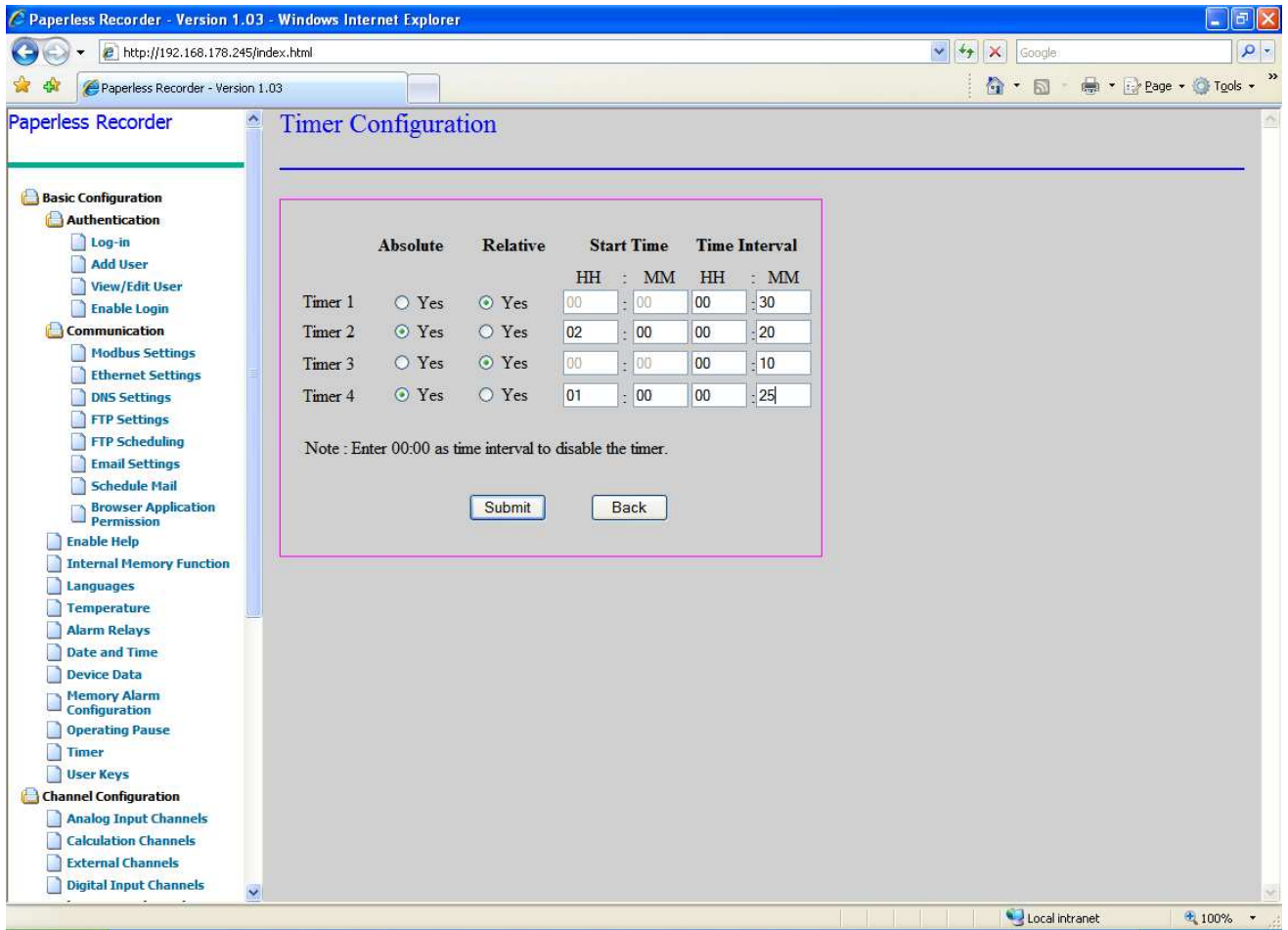

Figure 9. 29: Timer

### 9.2.1.13 User Keys

After selecting *User keys* option from *Basic configuration* menu, the screen will be displayed as follows.

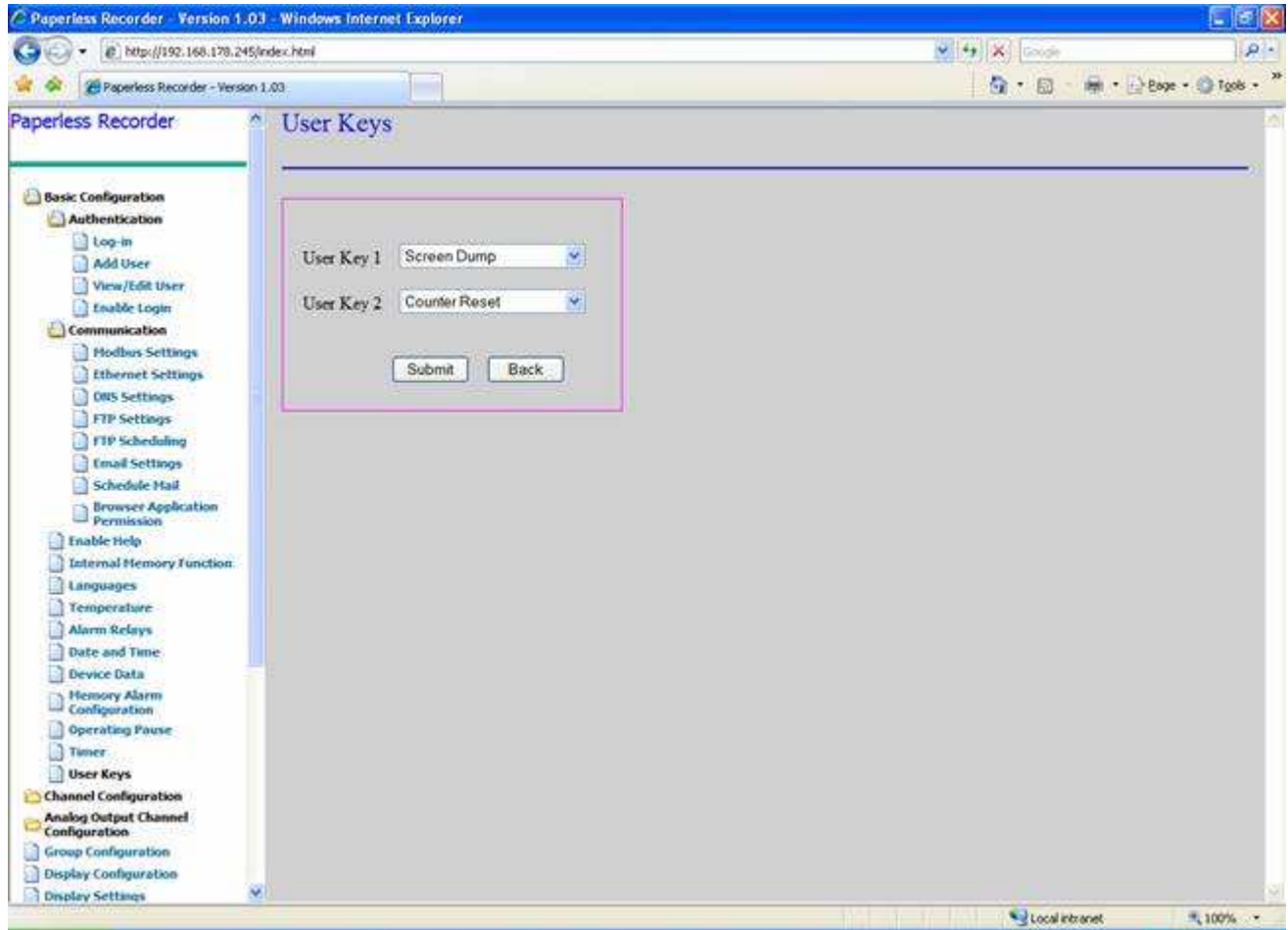

Figure 9. 30: User Key

Here the user has to select two different actions for the two user keys. After selecting the desired options for user keys 1 and 2 and after pressing the 'Submit' button, then the selected options will be updated in the bottom status bar of the recorder.

Therefore, a maximum of nine shortcut keys are available in recorder and they are as follows:

- Screen Dump
- FTP
- Email
- Reset Calculation
- Hide/Display Scales
- Hide/Display Numeric
- Batch Start/stop
- Change Display Type
- Counter Reset

For more details see the Recorder side *User Keys*.



## 9.2.2 Channel configuration

**Analog Input Channel:** After selecting “*Analog Input Channels*” from the structured menu the following screen will be displayed. (Only when Analog Input cards are available in Recorder for Normal mode)

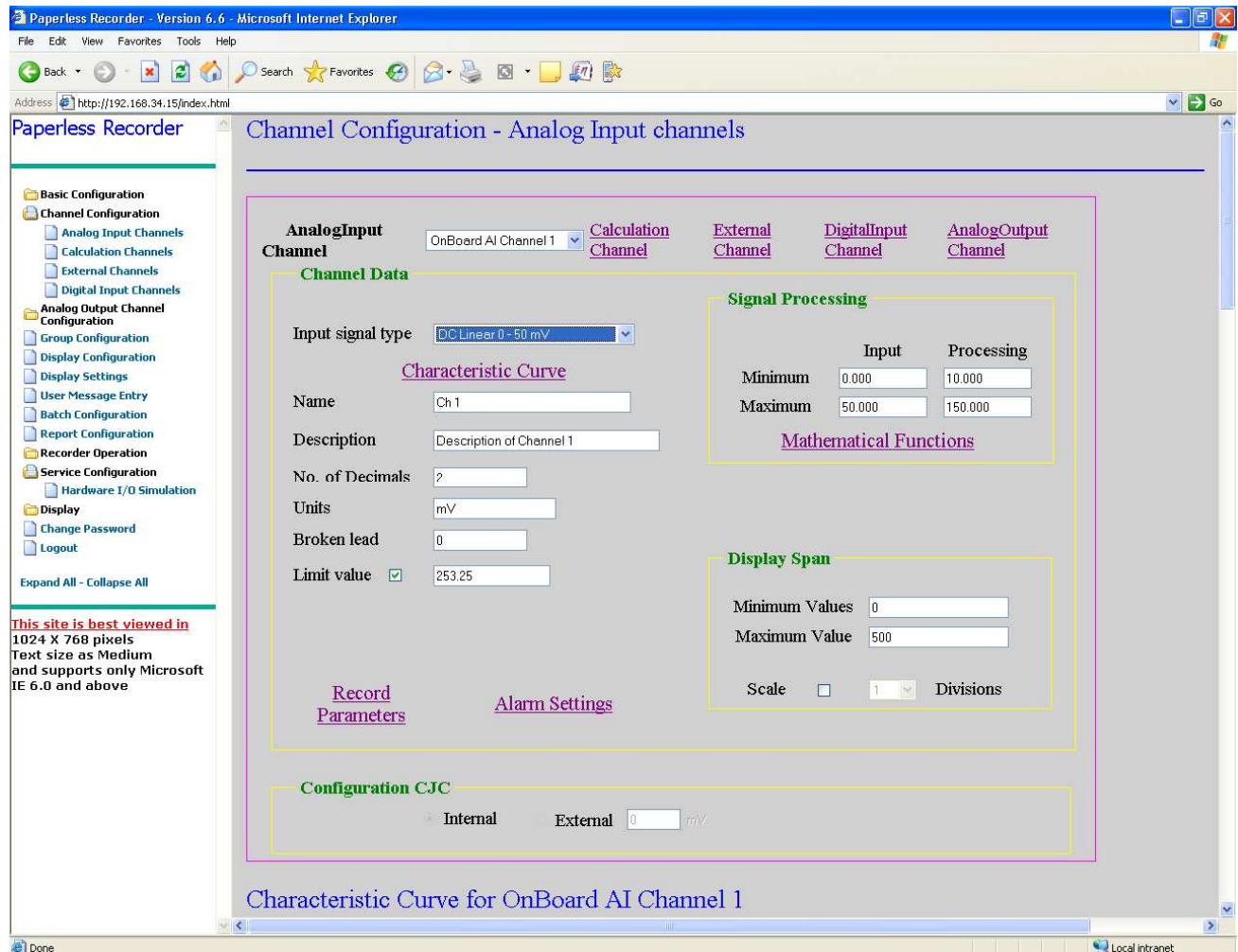

Figure 9. 31: channel Configuration

This page allows user to configure the Onboard Analog Input Channels.

To Configure the Calculation channel you have to click on the *Calculation Channel* hyperlink displayed in purple color, to configure the External channels you have to select the *External Channel* hyperlink, to configure the Digital Input channels you have to select *DigitalInput Channel*.

In the above screen,

**OnBoard Analog Input Channel:** Here recorder will lists only on-board analog input channels. Here if you want to enter the characteristics curve then click on the *Characteristic curve* link. Then it will go to the area (in same page) of the characteristics curve. The same is applicable for the *Record Parameters*, *Alarm settings*, *Mathematical Function*. And the [Top] and [Bottom] indicates the links to the top and bottom of the page.

**Input signal type:** This option will allow you to enter or change the input signal type for on-board analog input channels and it will also show the input signal type depending on the channel type. For Analog channels 33 input signals are available. If you select the different input signals for analog channels then the respective default values of Input Minimum, Input maximum, Process Minimum, Process Maximum and Display span Minimum and Display maximum values will display.

If you select Input Signal type which are not currently implemented as described in section 4.2-> Input Signal Type (Analog Channels) , an alert message will be displayed on the screen as shown in the figure below.

**Limit Value:** This field will allow user to restrict the processing value to cross the limit value. For more detail please refer section 4.2 channel configuration -> Limit value.

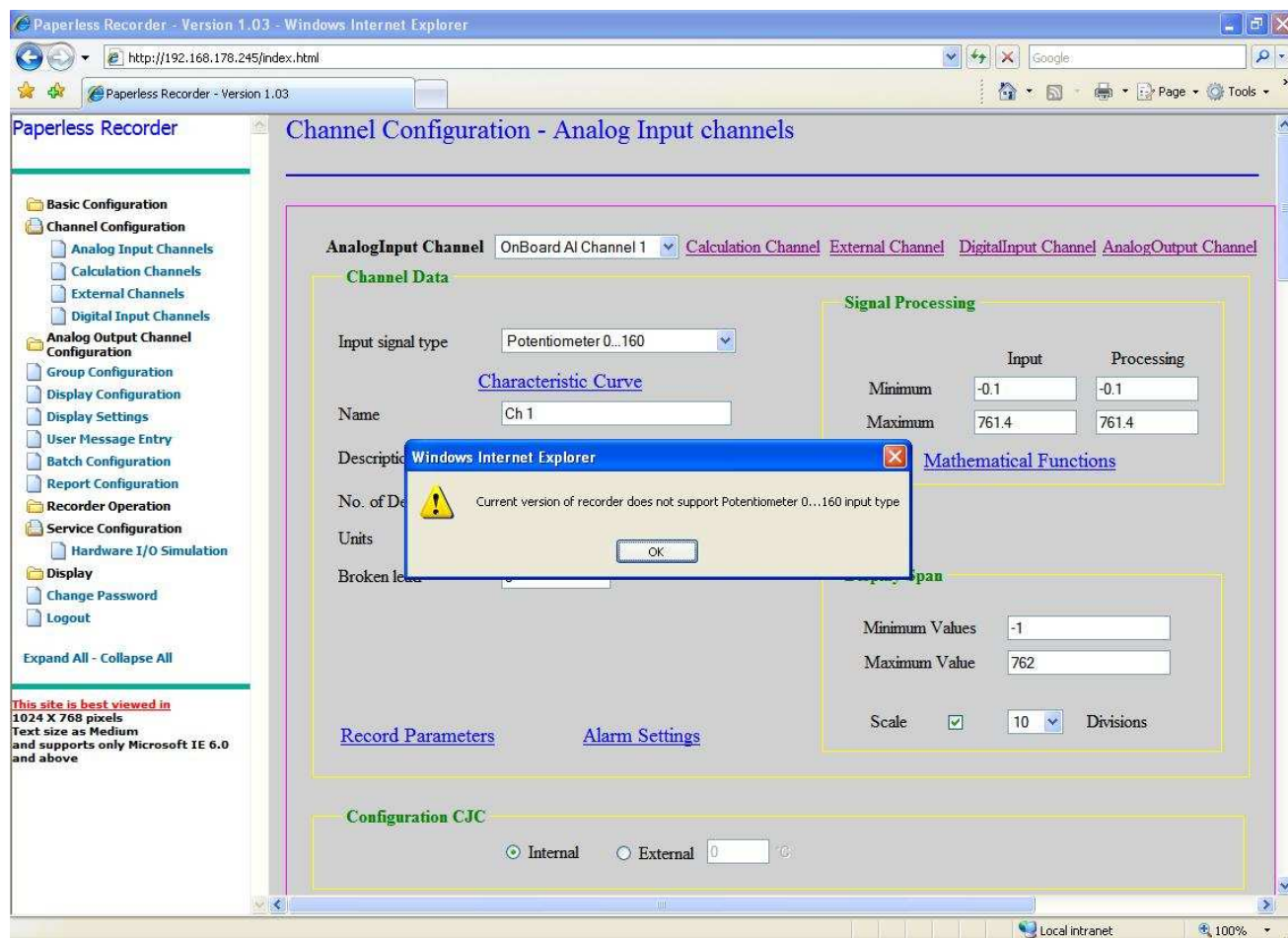

Figure 9. 33: On-board AI Channel Configuration-&gt; Input Signal Type

**Record parameters:** This option allows you to enter the recording parameters and the screen will be displayed as follows. Here you may select the different colors from the color combo box for the minimum, maximum, present, mean and peak values of a particular channel. If you want to set the custom color for the channel values then select the value's *Custom color* check box and select the color from the color palette shown in the following figure *Record Parameter Setting with color palette*. After selecting the color, the selected color will display in the edit box present near to the check box. For more details see the Recorder side *Record Parameters*

**NOTE:**

1. Only those values of a channel that have been selected for recording can be selected for display.

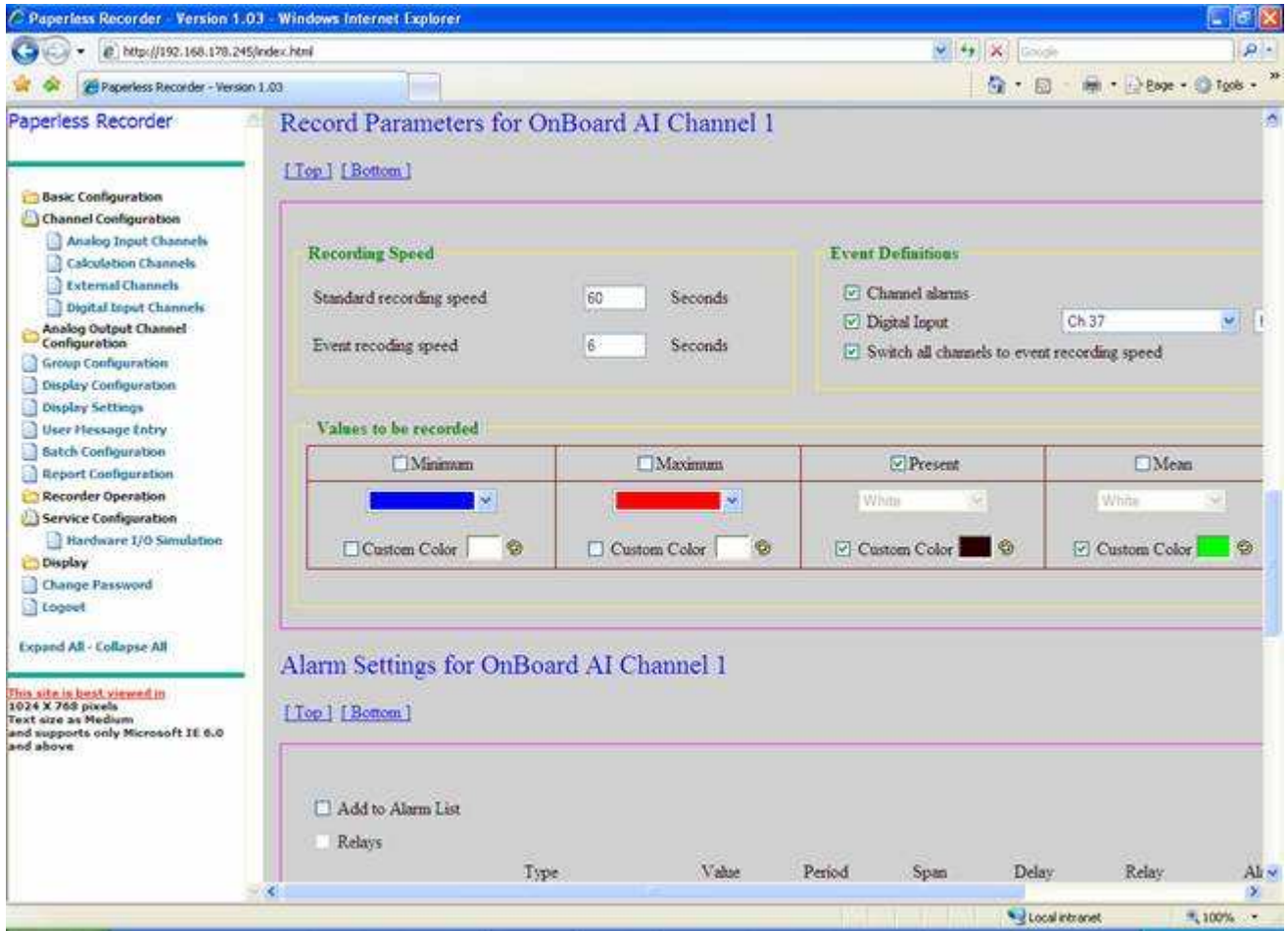

Figure 9. 324: Record Parameter Setting

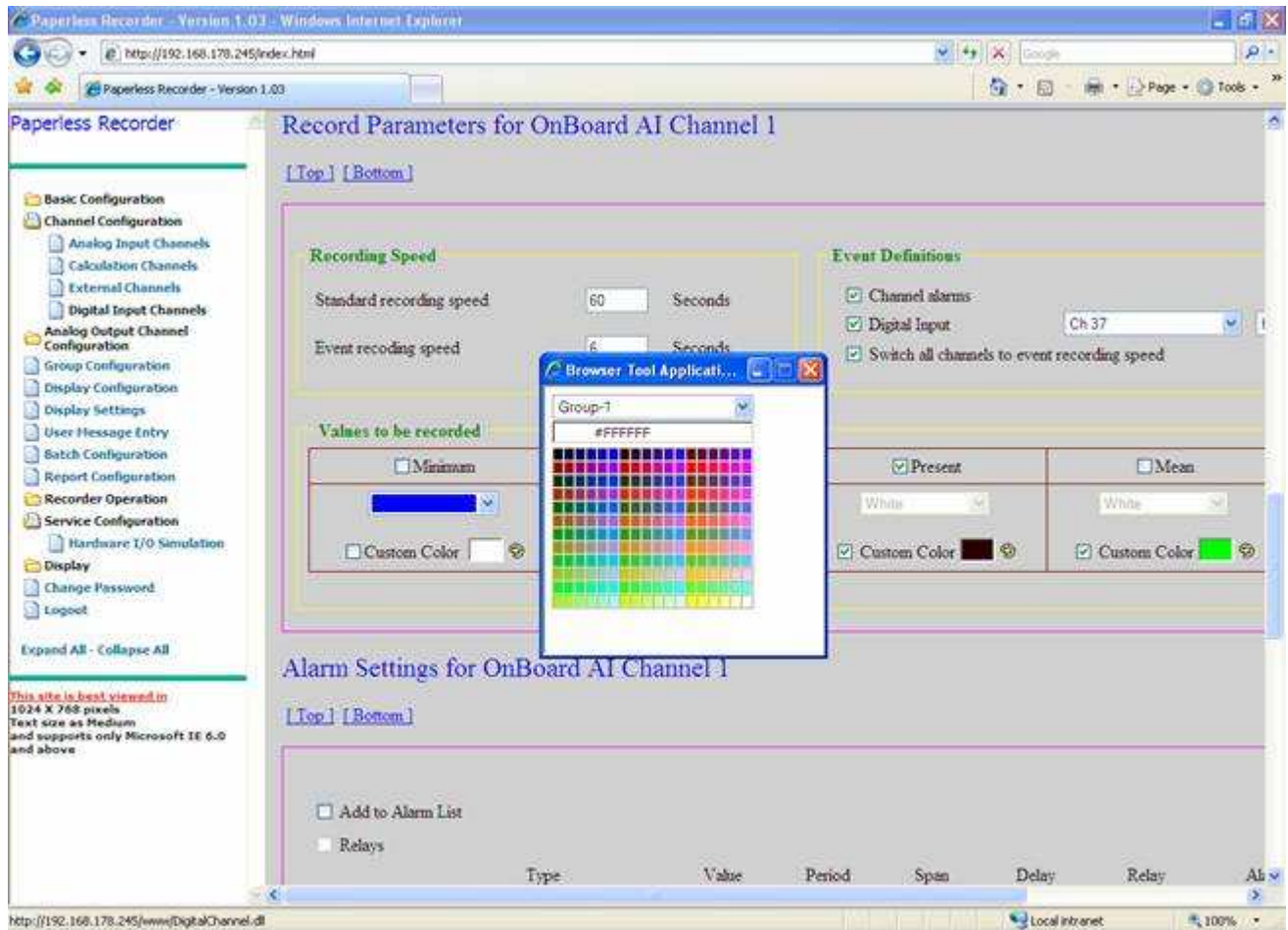

Figure 9. 335: Record Parameter Setting with color palette

**Alarm settings:** This option will allow you to enter the alarm condition. Maximum four alarms can be set for a channel. For more details see the Recorder side *Alarm Settings*

Refer recorder side details for further information on Broke lead , Recording speed parameters , Relay in alarm(refer section 4.2)

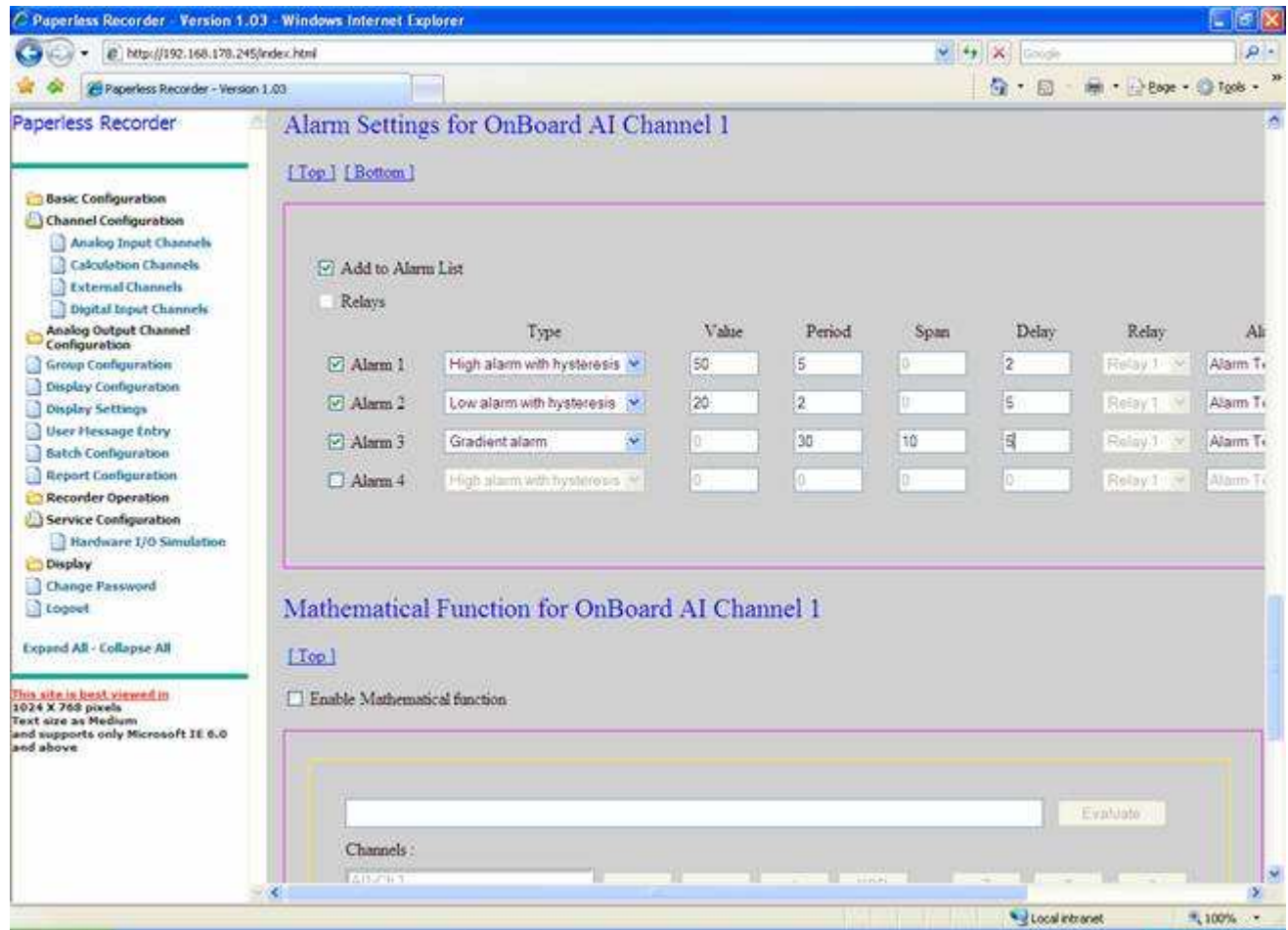

Figure 9. 346: Alarm Settings

**Mathematical Function:** This option is available for Onboard Analog and External channels. This option is for assigning the basic mathematical operations (+ - \* / sqrt etc.) on signal. It will display a page similar to calculation channel's math calculation with a limited number of mathematical operations available. The channel list will display the current channel. The format of the display channel is *AI-CH\_NAME* i.e. *AI* indicates Onboard Analog Input channel, similarly *EC* is for External channel and *CC* is for Calculation channel and *DI* for Onboard Digital Input channel. 1(one) indicates the channel number after that – (hyphen character) and the *CH\_NAME* indicates the name of the channel. To select the channel from the channel list, you have to double click on the channel, and then the required channel code is added into the expression field. For more details see the Recorder side *Mathematical function*

**Characteristic of the curve:** Characteristic curves are provided for the analog channels to allow defining a custom-mapping curve for a given range of analog inputs. Select the check box 'Enable Characteristic curve' to enable/disable characteristic curve mapping for the channel to be configured. To open the *Characteristic Curve* click on the *Characteristic curve* link present after the Input signal type. It will be display as follows. For more details see the Recorder side *Characteristic curve*.

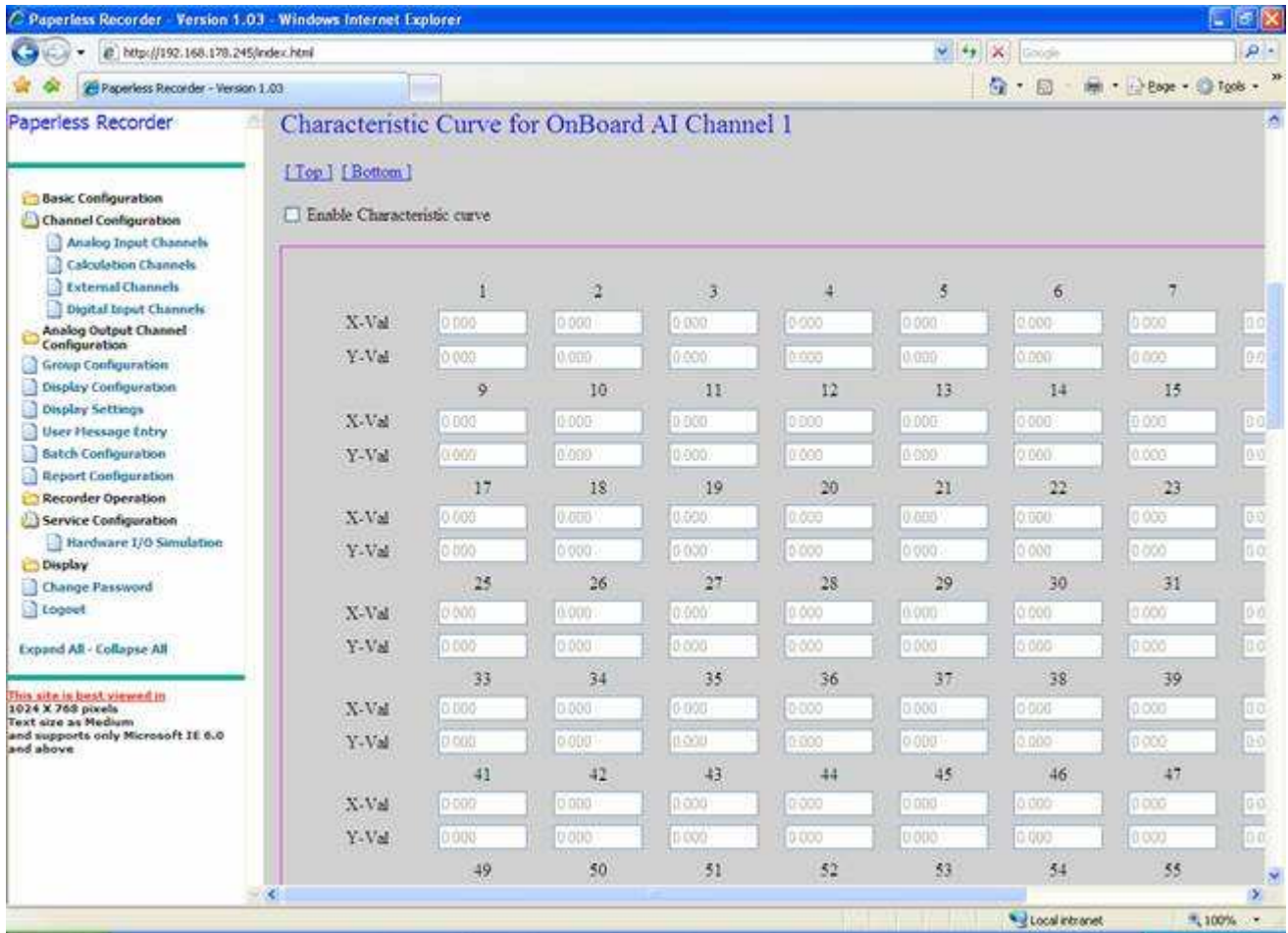

Figure 9. 357: Characteristic curve

If you select **TC Type** as the Input signal type then, the screen will be displayed as follows to allow you to enter the CJC Input as either External or Internal. If it is external, then you have to enter the CJC value. To save the settings of the *Onboard channel* click on channel wise *Submit* button. For more details see the Recorder side *Channel configuration*.

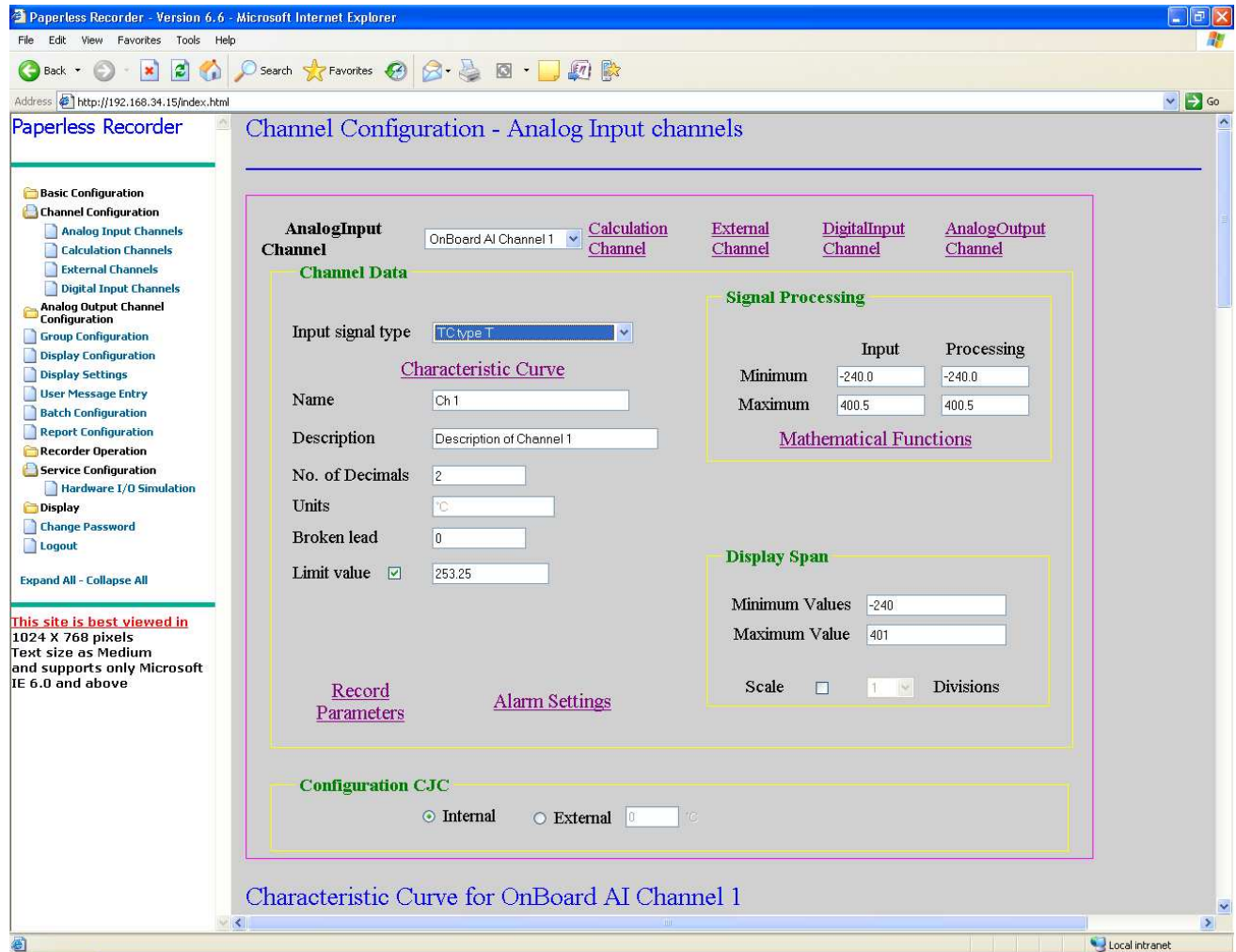

Figure 9.38: Channel configuration for analog with TC input

Note: 1. To save the settings of the *Analog Input channel* you need to click on channel wise *Submit* button.

2. After changing the setting for *Analog Input channel* all the graphs will be reset.

**Calculation Channel:** If you select any of the calculation channels to configure, the screen will be displayed as follows.



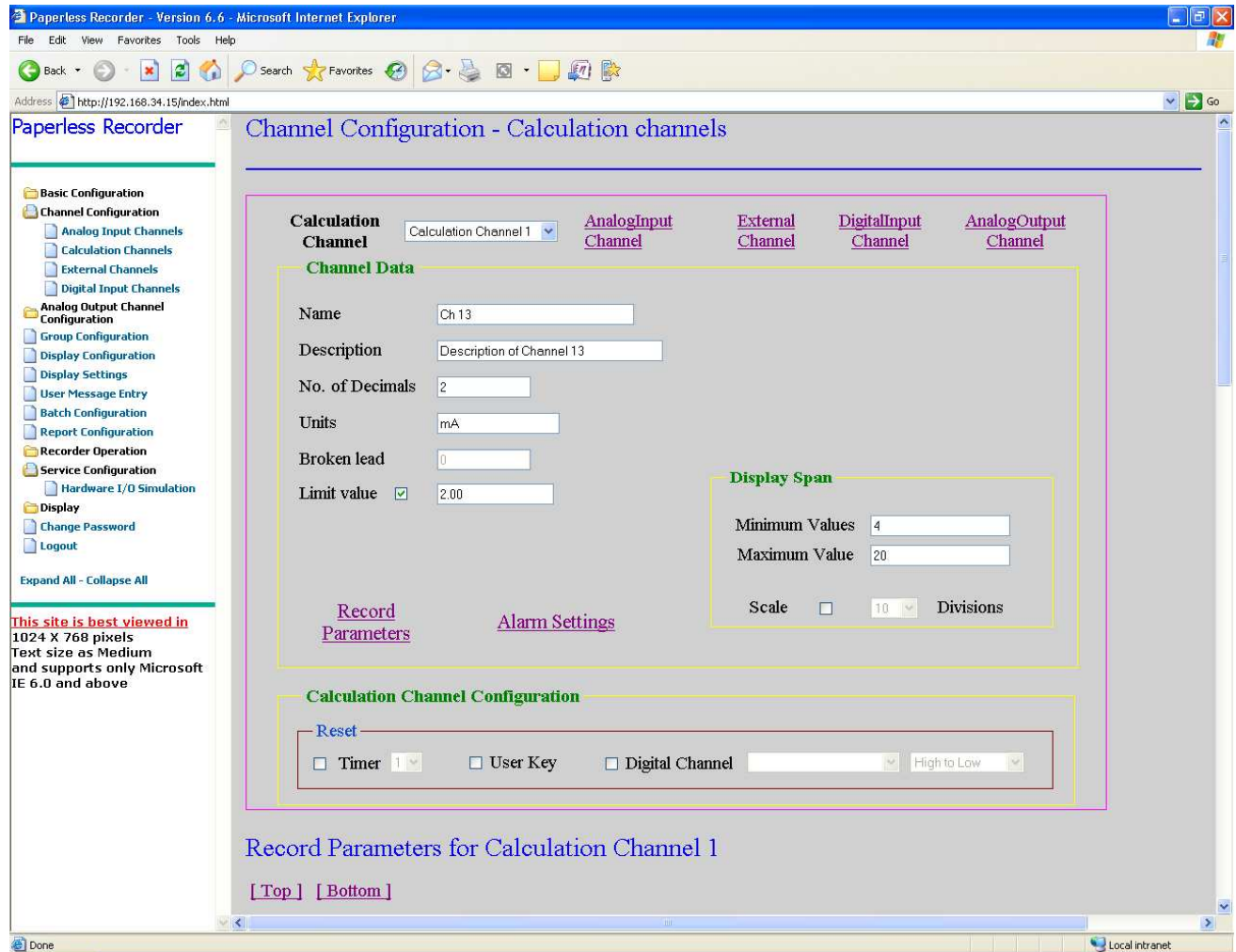

Figure 9. 39: Calculation Channel Configuration

To enter the expression for the selected calculation channel, you have to go at the end of the above shown page. After that the screen will be displayed as follows. If you want to perform some calculation on the current channel values e.g.  $AI1 * 10$  then select the 'AI-Ch 1' from the channel list and double click on it. Then the expression will be displayed in the expression edit box. If you modify any expression then you need to evaluate the expression by clicking on the 'Evaluate' button. For more details see the Recorder side *Calculation Channel*. The behavior of the remaining fields are same as mentioned in the description of other channel configurations

Note: The Onboard Analog Input Channels 1 to 12 are displayed as AI1 to AI12, External Channel 1 to 12 is displayed using EC1 to EC12 and Onboard Digital Input Channels 1 to 8 is displayed using DI1 to DI8.

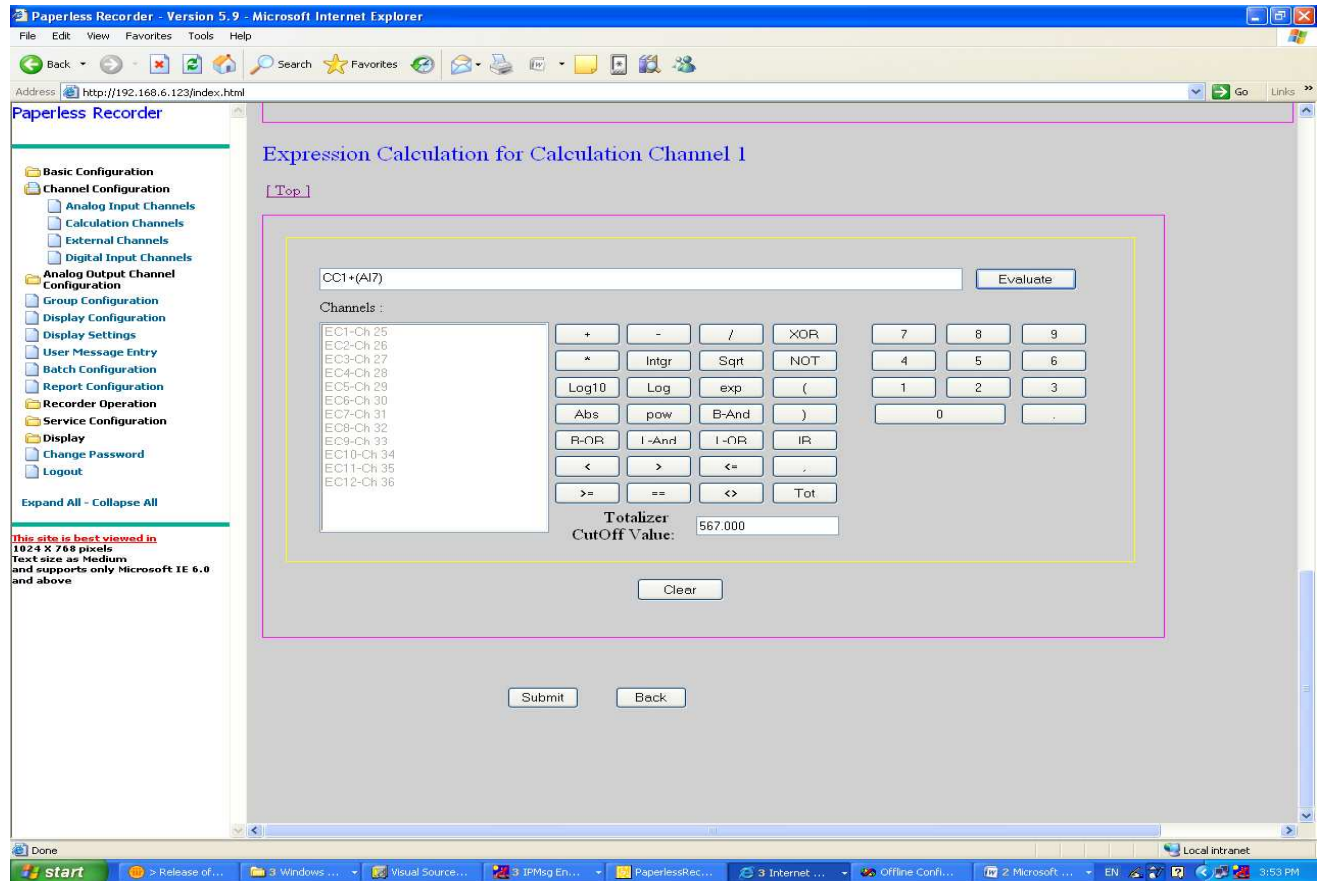

Figure 9.40: Expression Entry Screen

In the above screen,

**Evaluate:** evaluates the expression entered by you, for example if you enter:

$$AI1 + * AI2$$

This is a wrong expression, as it cannot be calculated. So an error message, “*Invalid expression*” will be displayed. If you enter a valid expression then it will display “*Valid Expression*” on the screen.

**Channels:** shows the list of available channels that can be used in an expression.

**Clear:** To clear the entered expression.

The operation for the buttons is assigned as follows:

Operation	Symbol
Addition	+
Subtraction	-
Division	/
Multiplication	*
Integration	Intgr
Square root	sqrt
Logarithm base 10	Log10
Natural logarithm	Log
Exponent	exp
Absolute value	abs
Exponentiation (x,y)	pow
bit-wise AND (x&y)	B-And
bit-wise OR (x y)	B-OR
Logic AND (x&&y)	L-And
Logic OR (x  y)	L-OR
Smaller than	<
Greater than	>
Greater than or equal	>=
Smaller than or equal	<=
Equal	==
Not equal (x!=y)	<>
XOR (x^y)	XOR
NOT	NOT
(	(
)	)
Integer Ratio	IR
Totalizer	Tot

For more details see the Recorder side *Calculation Channel configuration*.

Note: 1.To save the settings of the *Calculation channel* you need to click on channel wise *Submit* button.

3. After changing the settings for *Calculation channel* all the graphs will be reset.

#### **Totalizer functionality:**

Totalizer is a summation of channel value at a regular interval of time. The Tot button is providing Totalizer functionality to Recorder. If the user presses the “Tot” button it will reset

the previous expression (if it is there) and new expression will be added like “CC1+(.....)” depends upon the calculation channel selected.

For more details see the Recorder side *Calculation Channel configuration*.

**External Channel:** If you select any external channel to configure the screen will be displayed as follows.

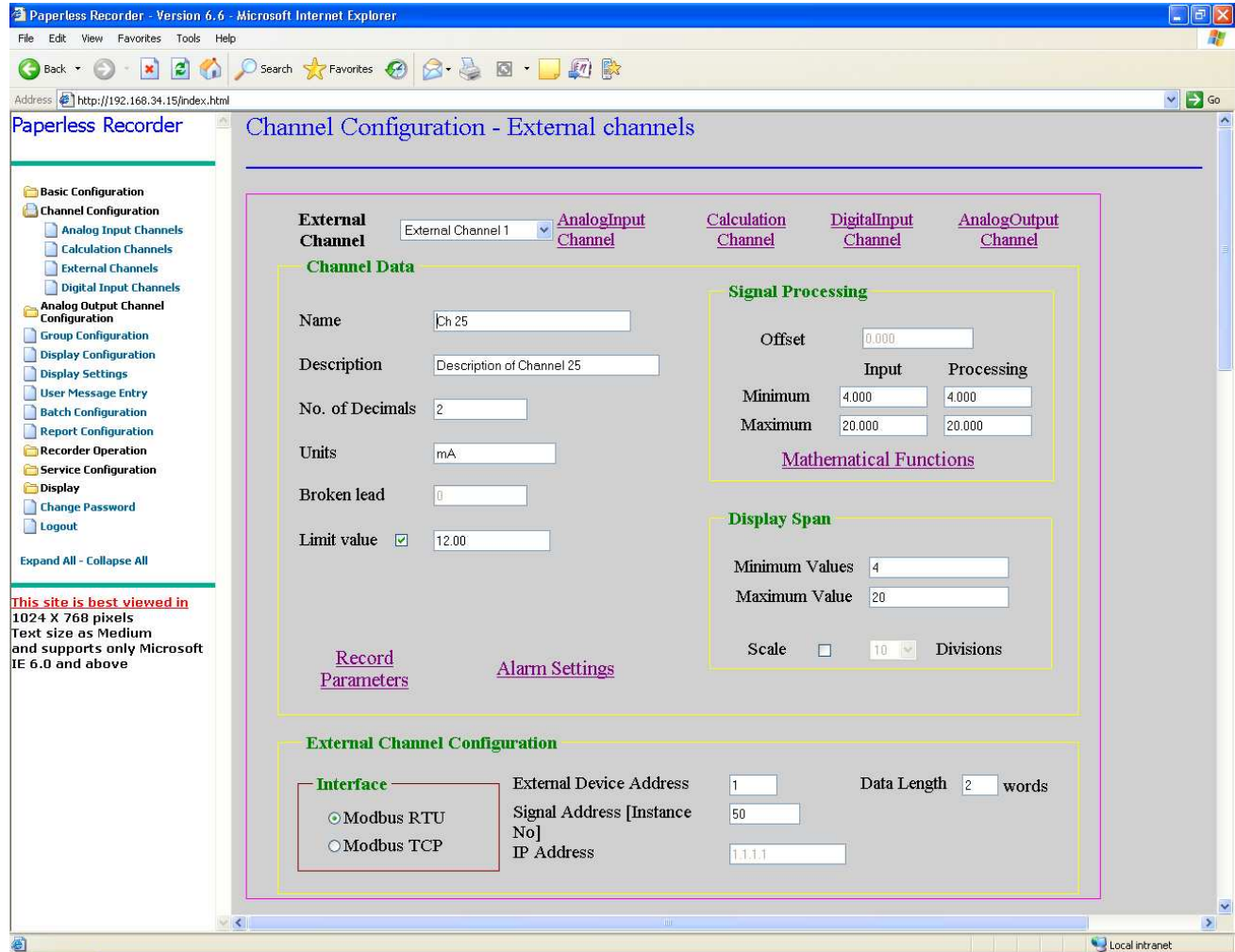

Figure 9. 361: External Input Channel Configuration

The configuration is the same as that of Calculation channels only difference is that some extra information about the external channel, such as Interface External Device Address, Signal Address and IP address has to be specified. The interface can be Modbus RTU or Modbus TCP. For more details see the Recorder side *External Channel configuration*.

Note: 1.To save the settings of the *External channel* you need to click on channel wise *Submit* button.

2.After changing the setting for *External channel* all the graphs will be reset.

**Digital Input Channel:** If you select any digital input channel to configure the screen will be displayed as follows.

The Configuration is similar to that of Analog Input Channels but for Digital channels “Characteristic curve” and “Mathematical Function” options are not provided instead it is given with an option “Link Message”. And unlike Analog Input Channel , Digital Input Channels are provided with three Input Signals ”Counter Input” , “Operating hours counter” and “1:1” . The number of decimals field is Read-only for DI channel configuration page.

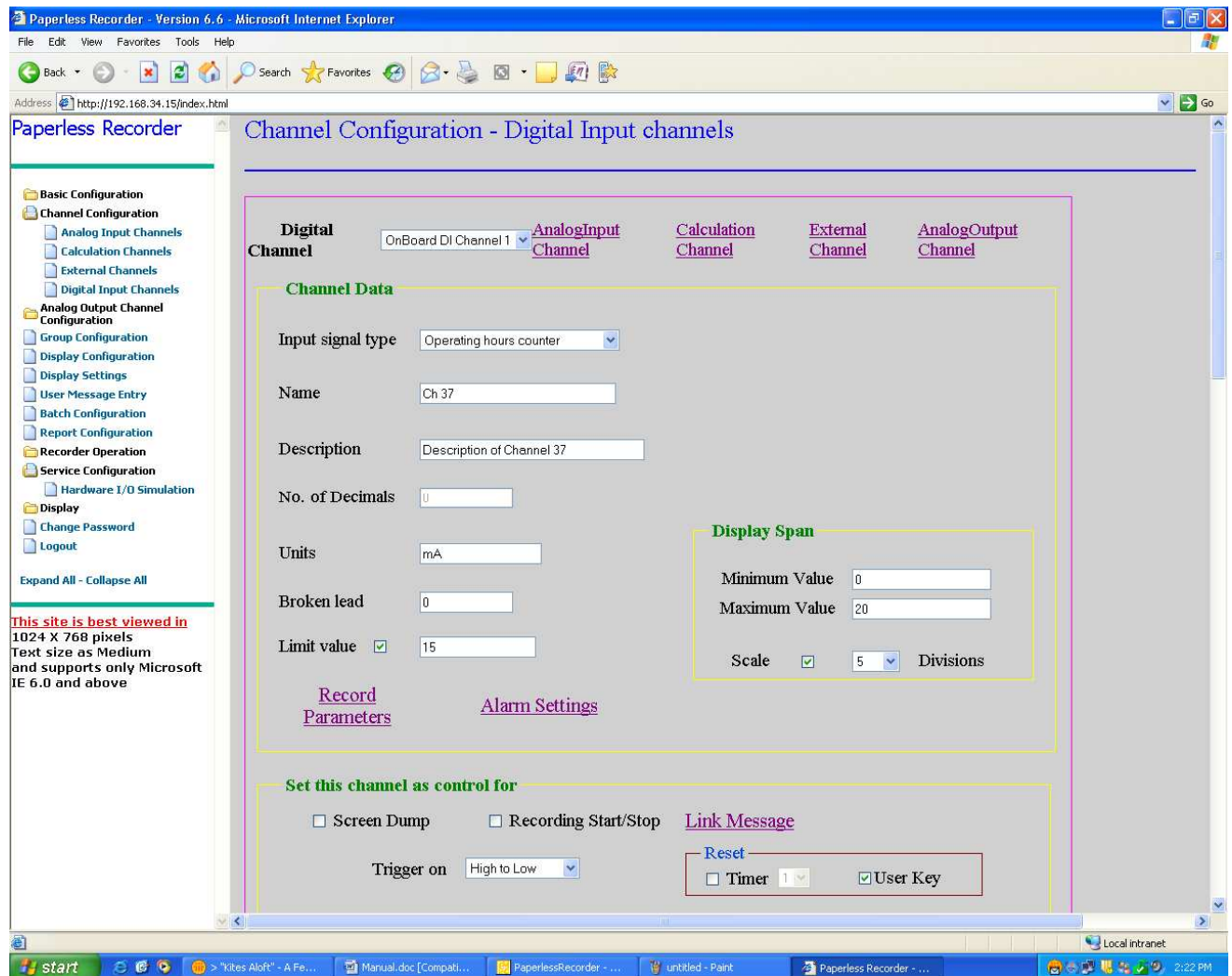

Figure 9. 42: Digital Input Channel Configuration

**Link Message:** If you select the '*Link Message*' to configure, the screen will be displayed as follows. This option is only available for the OnBoard Digital Input channel. Here you may assign the predefined or user defined message to a digital channel. For more details see the Recorder side *Link Message*.

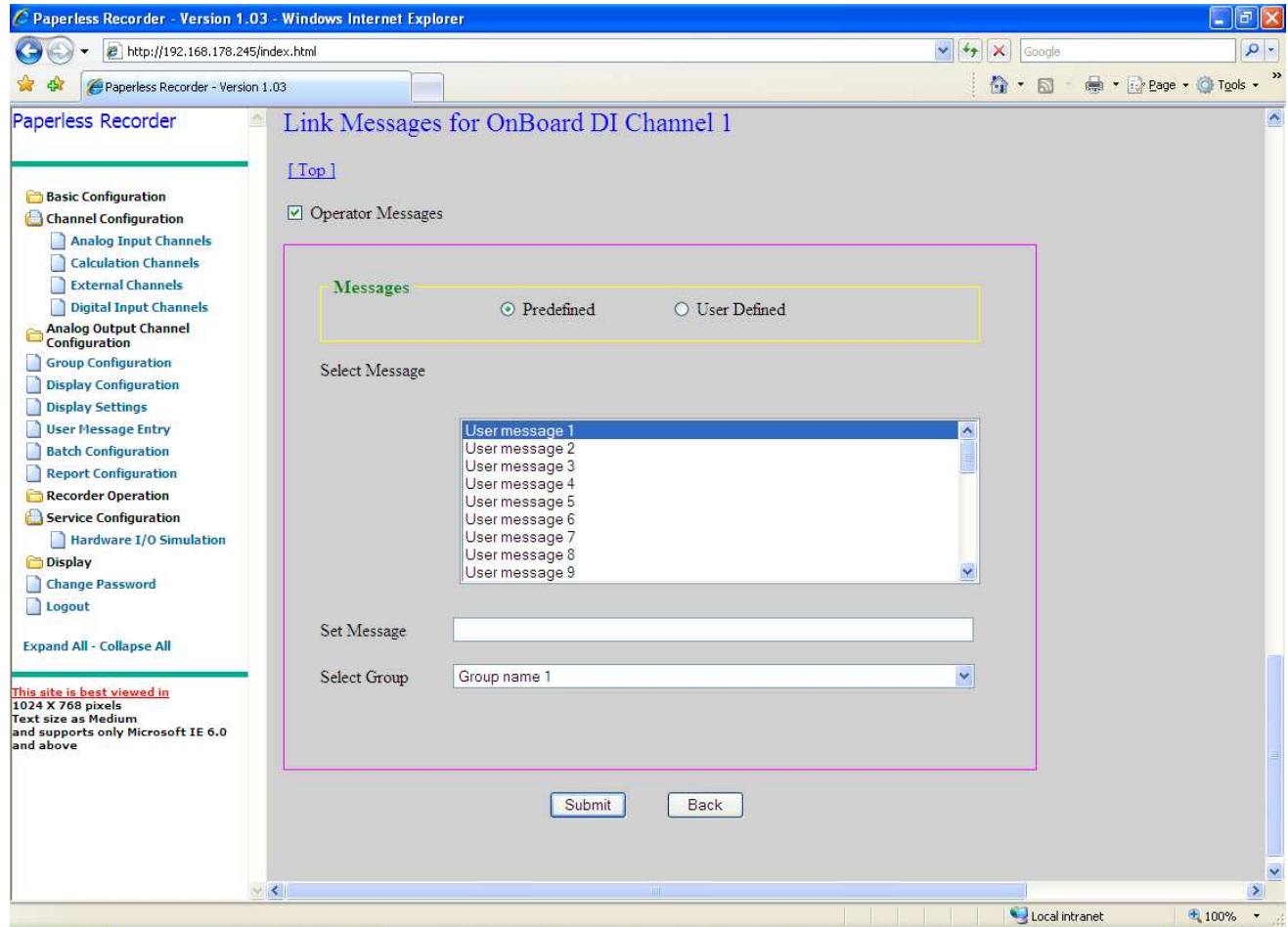

Figure 9. 43 Digital Input Channel – Link Message screen

- Note: 1. To save the settings of the *Digital Input channel* you need to click on channel wise *Submit* button.
2. After changing the settings for *Digital Input channel* all the graphs will be reset.
3. *Minimum, Maximum, Mean* and *Peak* values are the same as *Present* values for Onboard Digital Input Channels.

**Alarm Settings:** On selection of Input Signal Type to 1:1 the alarm values entered is restricted to only 0 or 1. Any other value entered would be restricted as is shown below. The alert displayed will show the message “For Input Type 1:1 alarm value can only be 0 or 1.

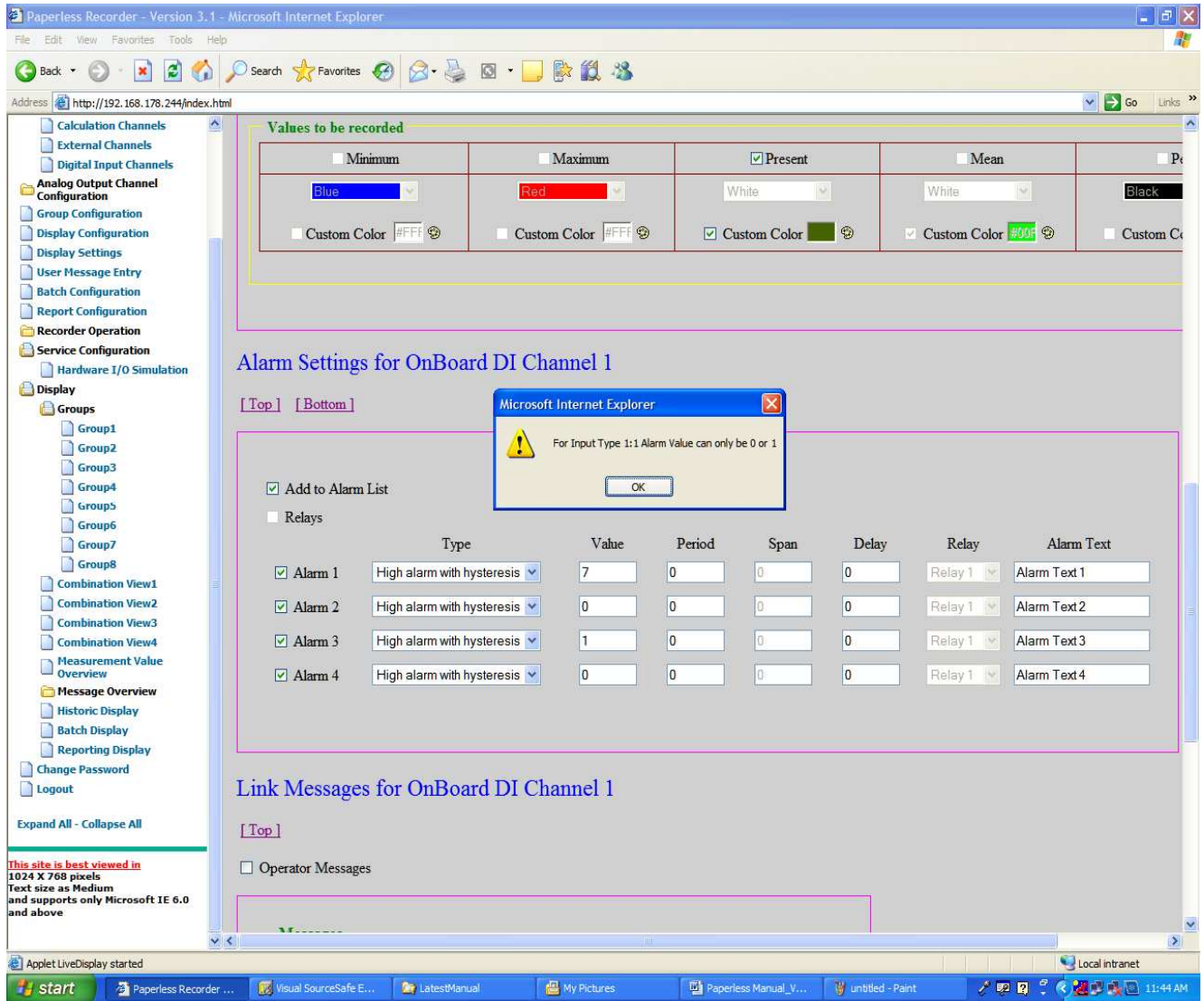

Figure 9. 44 Digital Input Channel – Alarm Settings screen

**Record Parameters:** Standard Recording Speed cannot have value other than 1 sec. On entering any other value will prompt an alert showing the message “Invalid Standard Recording Speed value, Enter 1”

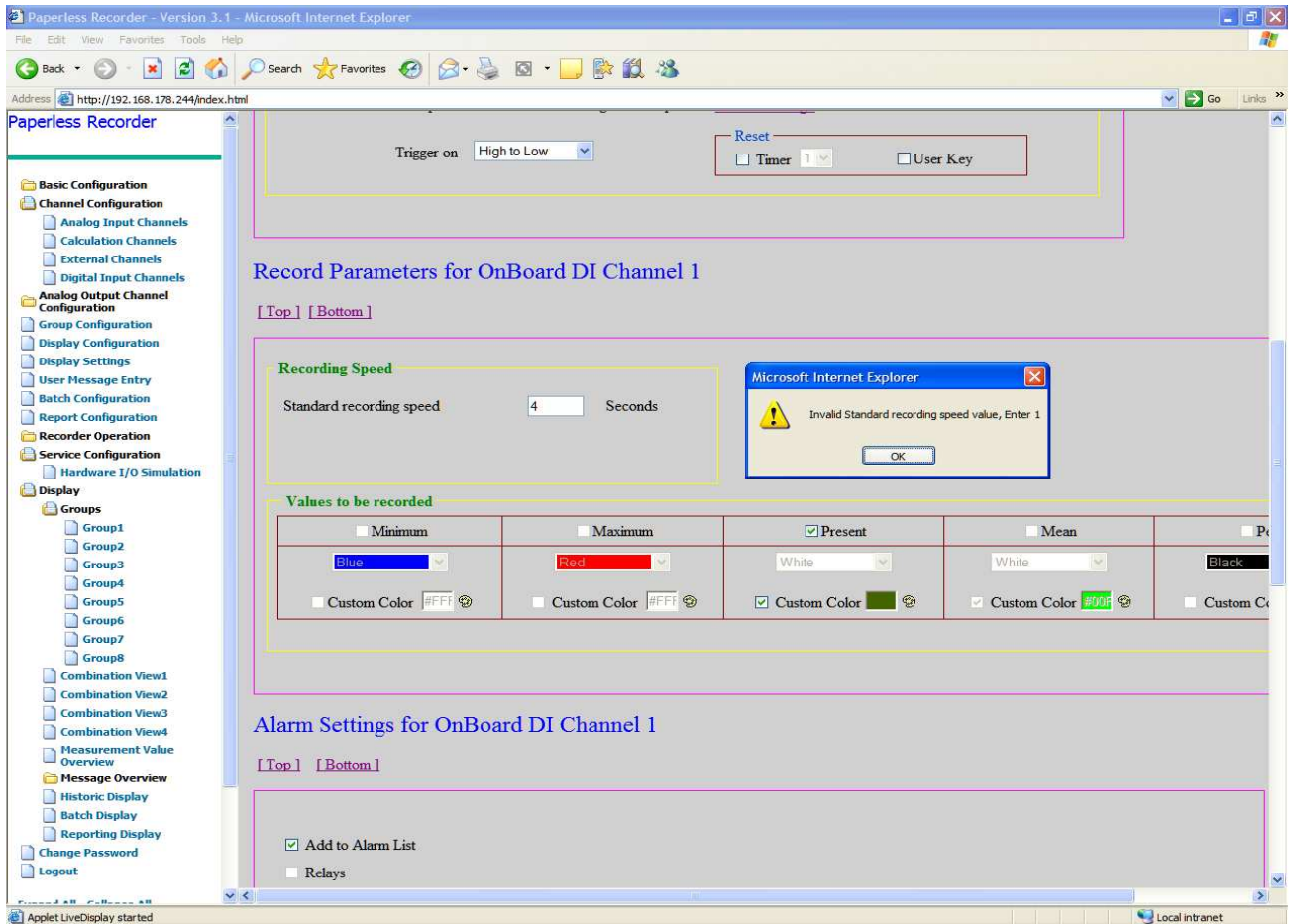
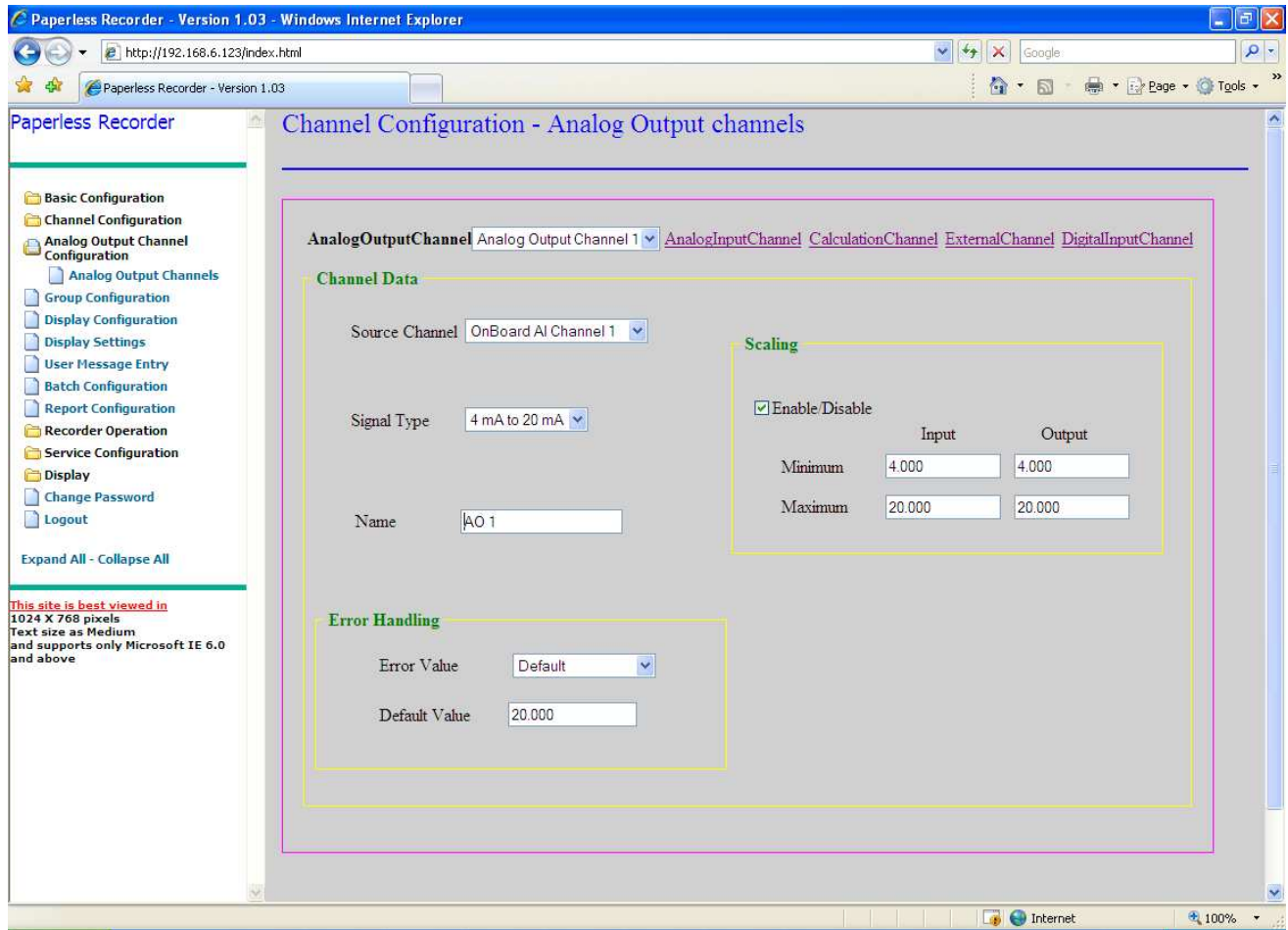

Figure 9. 45 Digital Input Channel – Record Parameters screen



### 9.2.3 Analog Output Channel Configuration

**Analog Output Channel:** If you select any Analog output channel to configure the screen will be displayed as follows. Here recorder will list only onboard analog output channels.



9. 44 Analog Output Channel configuration screen

Here you will be allowed to select *Source Channel* among entire available channel and *Signal Type* ((0 to 20mA ) OR (4 to 20mA)).

You will also be allowed to select *Error Value*. The 3 *Error Value* types available are

- 1> Last Value Output
- 2> Zero
- 3> Default

If *Default* option is selected you will have to enter “*Default Value*”.

**Scaling:** Here you will be allowed to enter *Input minimum*, *Input Maximum*, *Output Minimum* and *Output Maximum* only if the “*Enable/Disable*” check box is checked otherwise *Input minimum*, *Input Maximum*, *Output Minimum* and *Output Maximum* text boxes will be disabled.

Note:

1. To save the settings of the *Analog Output channel* you need to click on channel wise *Submit* button.
2. In the absence of AO Cards if the user tries to open the Analog Output Configuration dialogue it will display a message “Current version of recorder, won't support the Analog Output channels.”

### 9.2.4 Group Configuration

By selecting “*Group Configuration*” from tree-structured menu the screen will be displayed as follows.

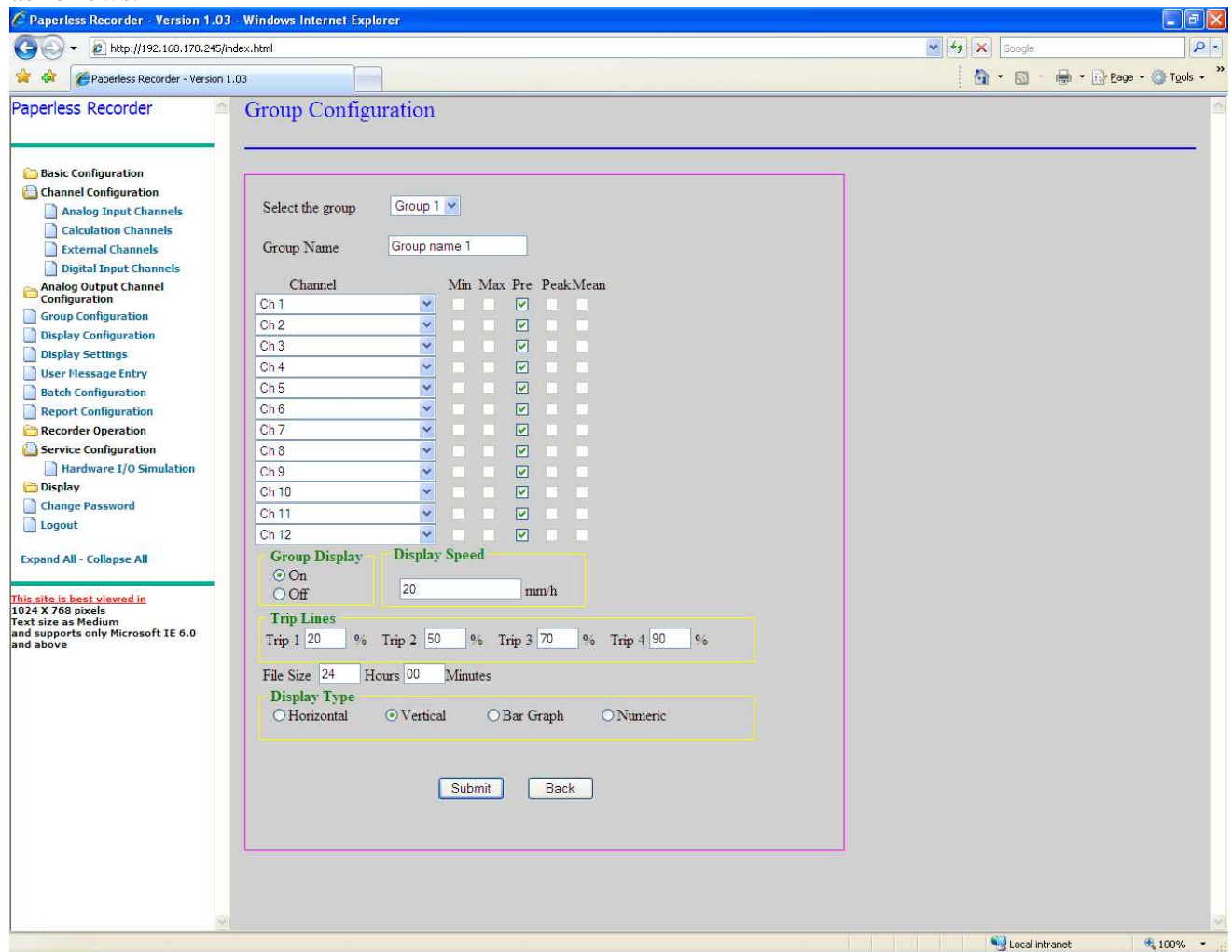

Figure 9. 375: Group Configuration

Group is a collection of channels. A maximum of 12 and a minimum of 1 channel can be added in a group. You can view all values (minimum, maximum, present, peak and mean) of a channel, they are considered as separate channels for display. Maximum eight groups are available to configure.

You may configure each group by entering group name, selecting the channels, ON\OFF, display speed, trip line, file size in hours and minutes and type of display as Horizontal, Vertical, Bar graph, Numeric. Here you may enter the value of the display speed in between 1 to 734. And the maximum file size available is 1152 hours (48 days). Also you may configure the channels to be displayed in the selected group by selecting the enabled check box present in front of the channel list. The enable\disable of the channel value depends on the configuration of the channel. To configure the different groups you have to select the group from “*Select the group*” box. To deselect or remove the channel values from the group, deselect all the check boxes in front of the channel list. For more details see the Recorder side *Group Configuration*.

Note: 1.To save the settings of the *Group configuration* you need to click on group wise *Submit* button.

2. After changing the setting from the *Group Configuration* all the graphs will be reset.

## 9.2.5 Display configuration

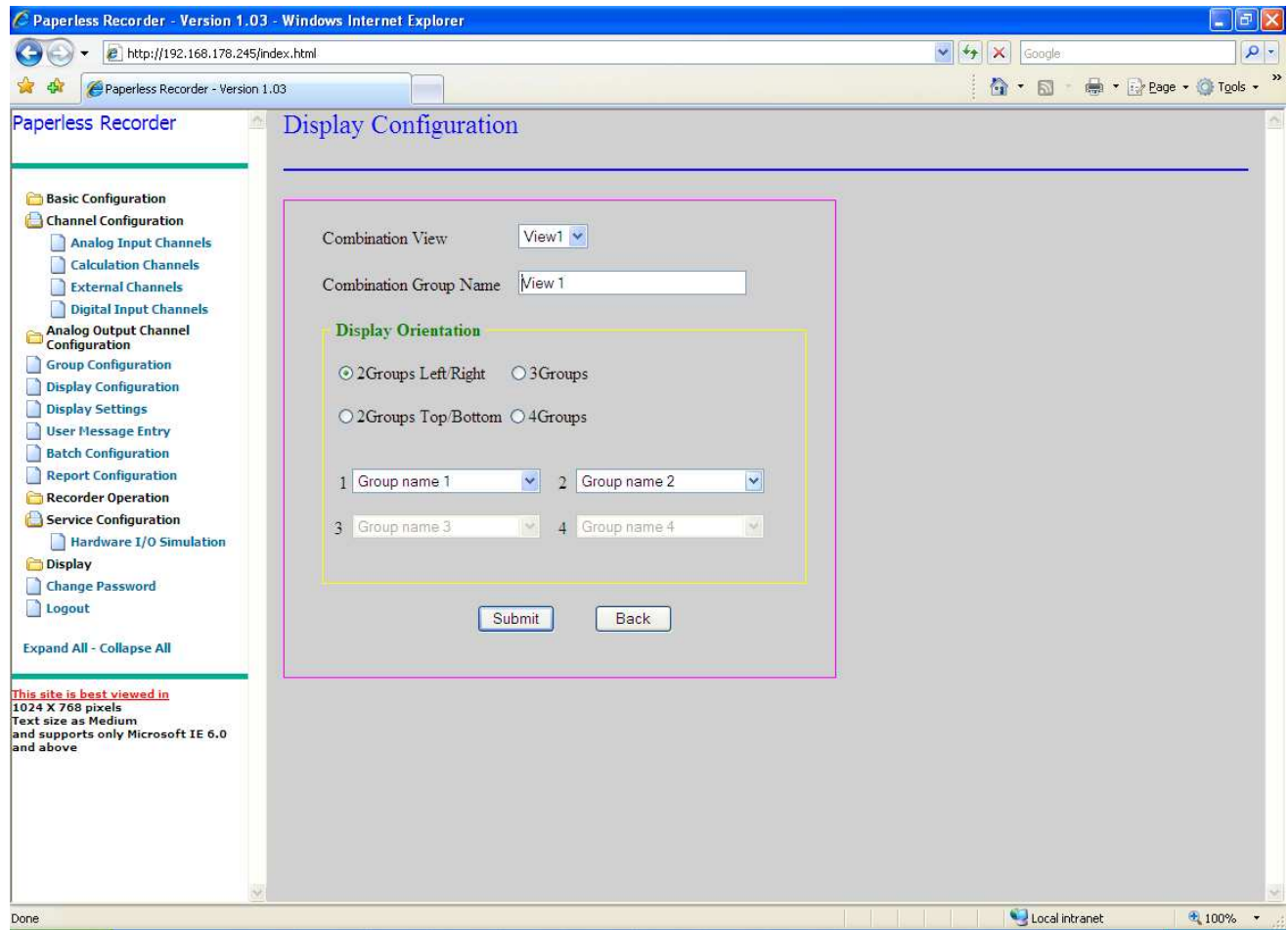

Figure 9. 386: Display Configuration

The *Display Configuration* will allow you to create up to four combination views and to specify a Combination Group Name. You can select any of the four Display Orientation options and then select the required groups from the list of groups displayed in the corresponding regions of the screen. If any group is 'OFF' in *Group configuration* then that group will not be added into the group list. For more details see the Recorder side *Display configuration*.

Note: 1.To save the settings of the *Display configuration* you need to click on the view wise *Submit* button.

2. After changing the setting from the *Display configuration* only the combinational view graphs will be reset.

### 9.2.6 Display settings

LCD display and Screen saver options are not implemented in the current version. The rest of the description related to display setting are as follows:

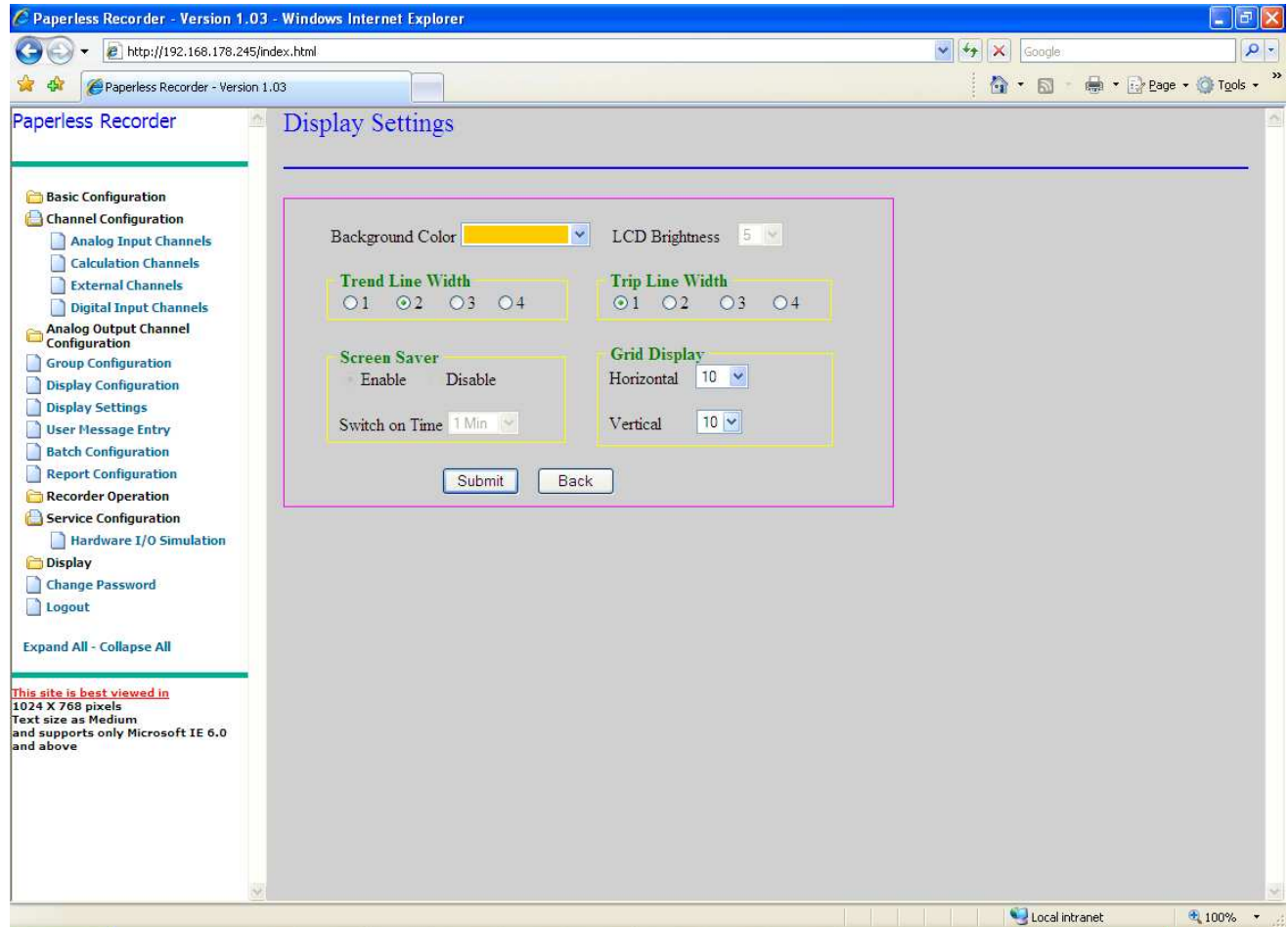

Figure 9. 397: Display Setting

When you select Background color, the color combo box will be displayed as follows.

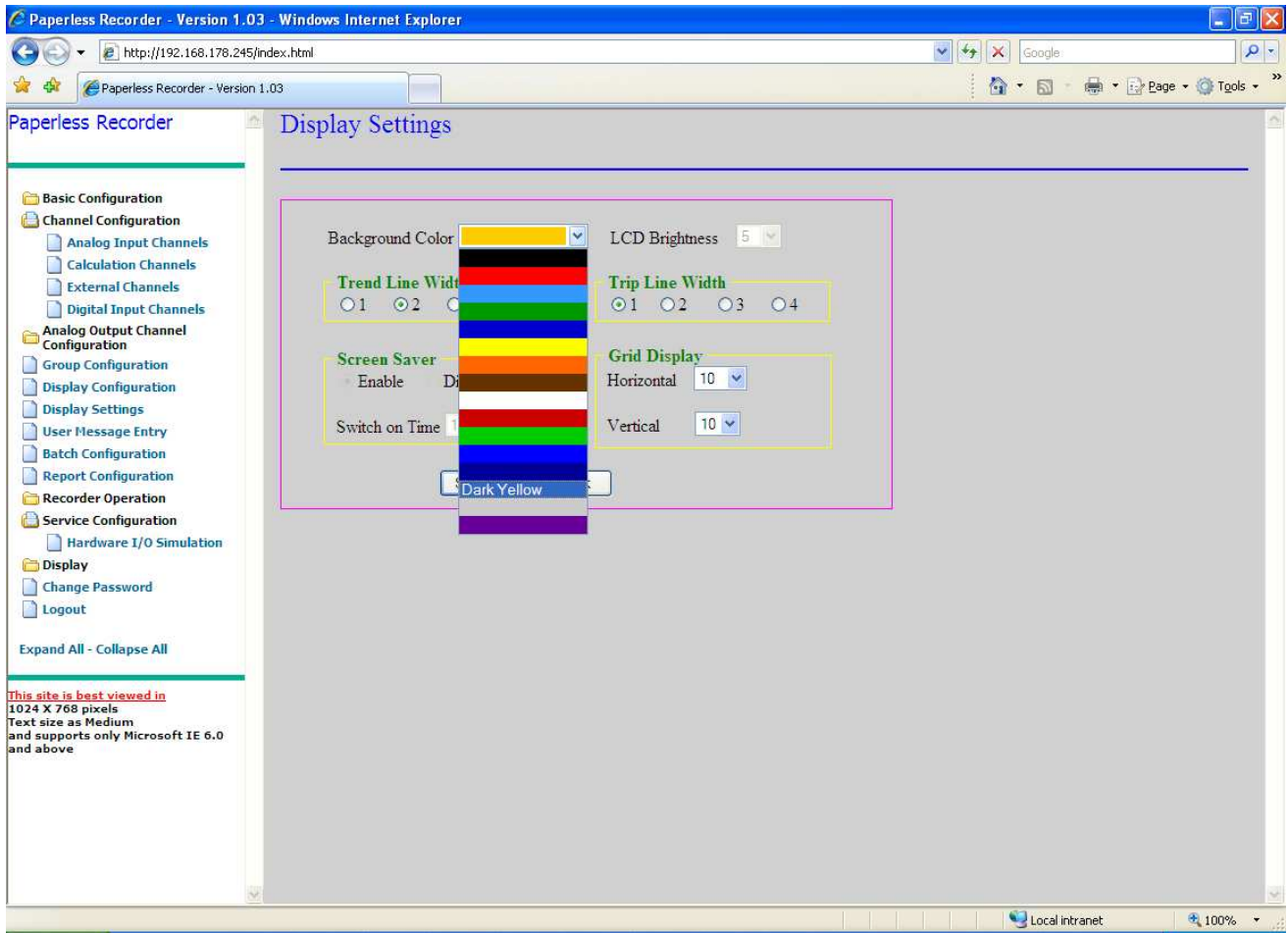

Figure 9. 40: Color Dialog Box

You can choose any of the colors provided from the color combo box. After selecting a color, the respective color name will be displayed in the combo box. You can also set the width of the trend lines and trip lines to 1/2/ 3 / 4 pixels respectively. The Grid Spacing for horizontal and vertical displays can also be set as pixels. For more details see the Recorder side *Display settings*.

Note: After changing the setting from the *Display settings* all the graphs will be reset.

## 9.2.7 User Messages Entry

The “*User Messages Entry*” menu option allows you to predefine up to 32 text messages. You may save all the predefined user messages for future use by clicking on the “*Submit*” button. The list of user messages will be used in *User Message* or *Link Message* for a digital channel. For more details see the Recorder side *User Messages Entry*.

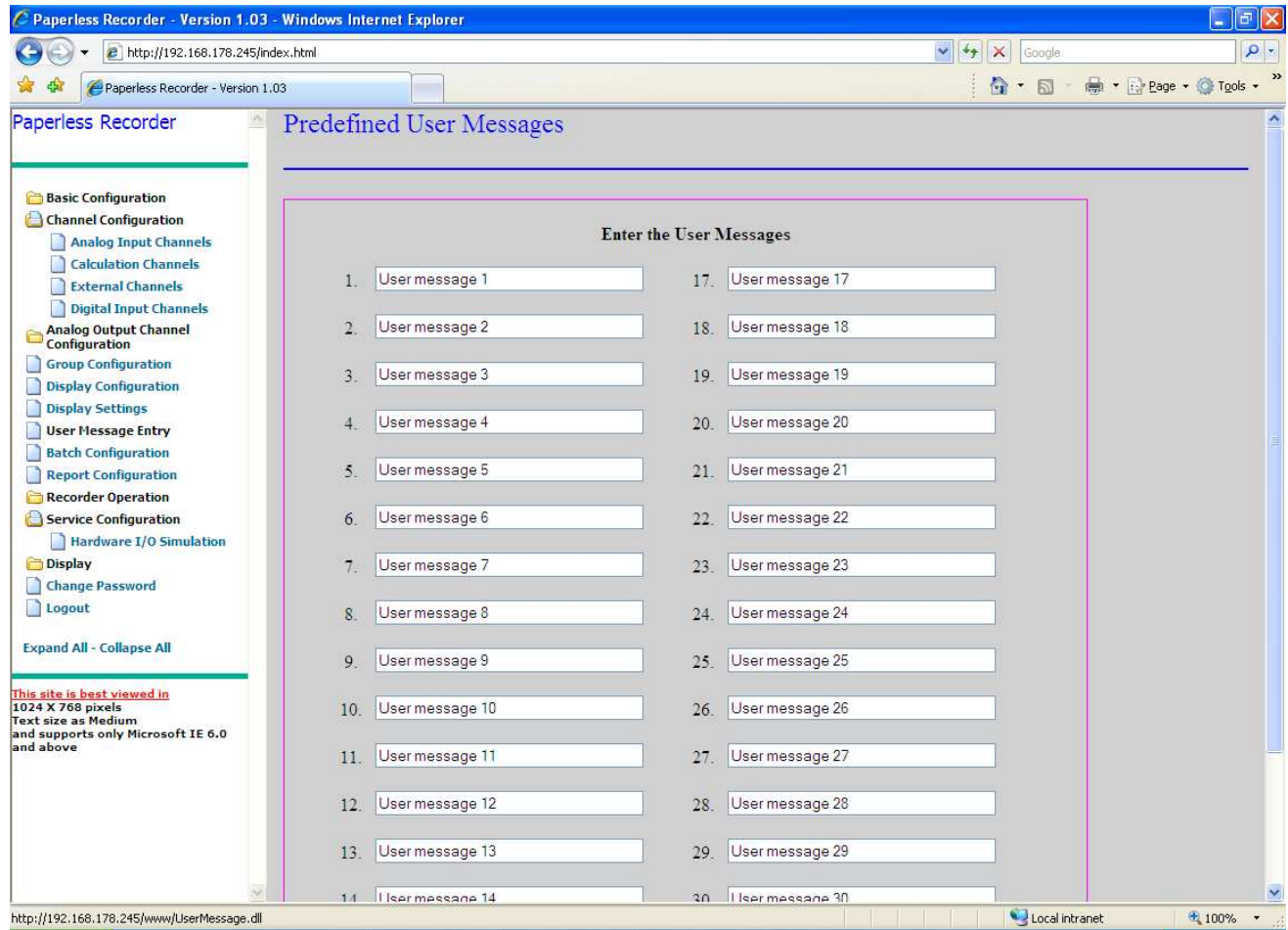

Figure 9. 41: User Messages

### 9.2.8 Batch configuration

The *Batch configuration* option of the tree-structure menu allows you to configure batches. The Configure option is as follows.

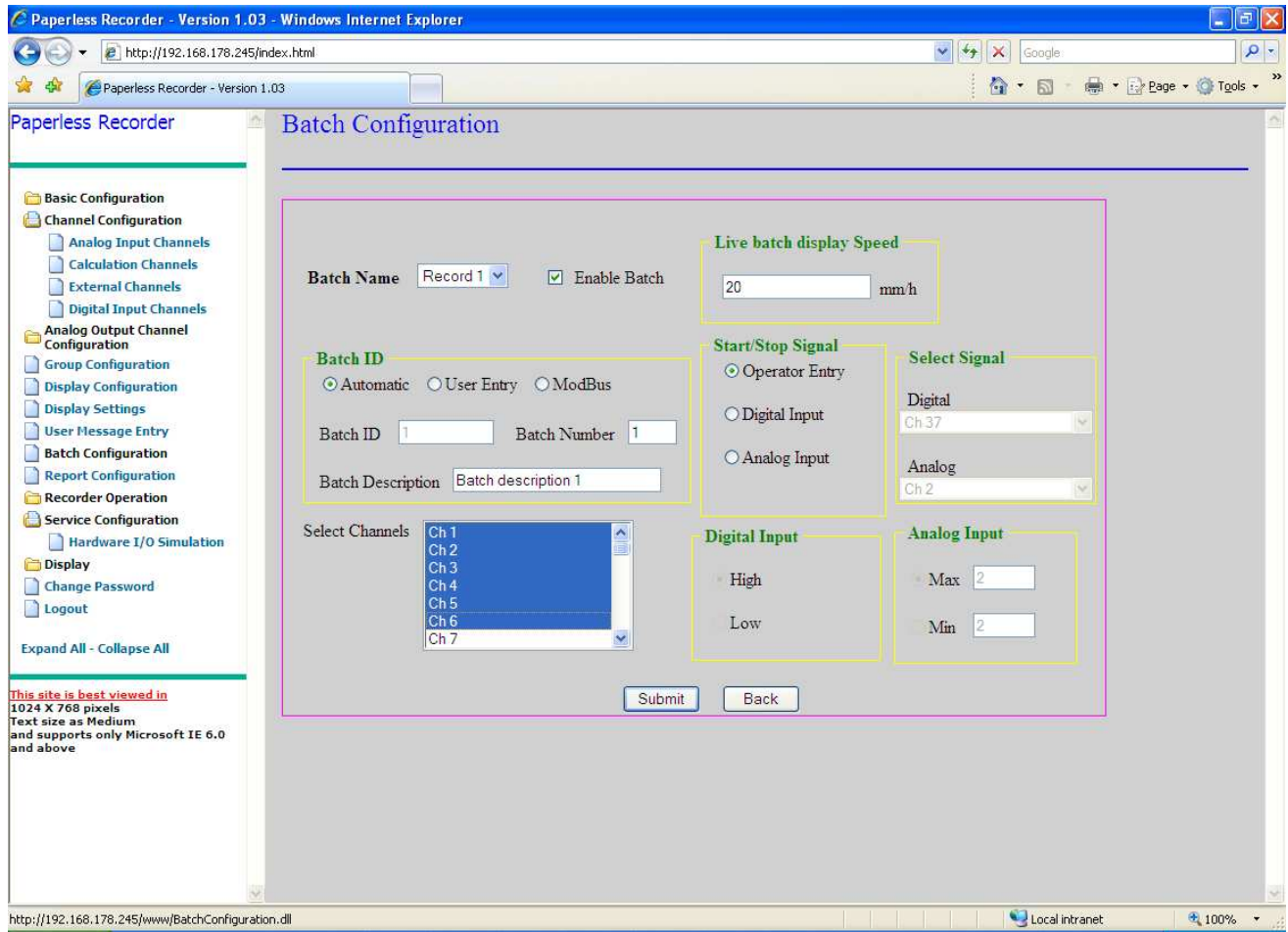

Figure 9. 50: Batch Configuration

Here you must check the “Enable Batch” check box to do any configuration. If the “Enable Batch” check box is unchecked the page displayed will be as follows



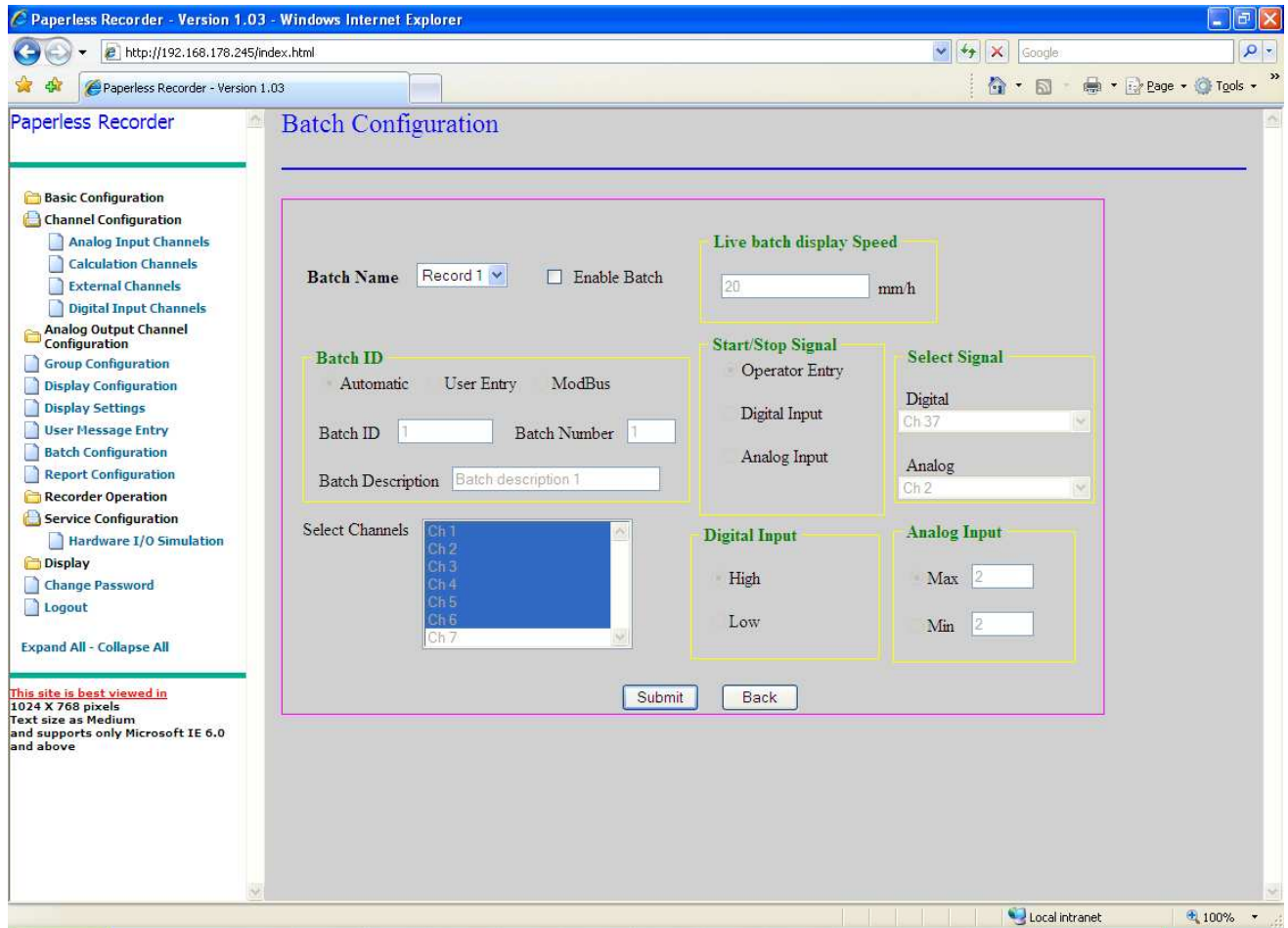

Figure 9. 51: Batch Configuration

Here you must first select the Batch name, then provide the Batch ID, Batch Number and Batch description. The batch id can be provided automatically or by the user or through a MODBUS, depending upon the option selected. If you select *User Entry* then you have to enter *Batch ID* and *Batch Number*, for the rest two options *Automatic* and *ModBus* “*Batch ID*” and “*Batch Number*” fields will be disabled. You also have to select the required channels for a batch and specify the display speed for live batch in mm\hr (enter between 1 to 734).

You also have to specify the Start/Stop signal for the record generation. If the operator entry option is selected then you have to use the User Keys provided in the short cut bar to trigger batch recording. If digital input is selected, then you must specify the digital signal to be used as well as if, it’s a digital high or low that will trigger the recording. For an analog input you must specify if it’s a Max value or Min. value and also select the analog channel to be used as the trigger. For more details see the Recorder side *Batch Configuration*.

Note: 1.To save the settings of the *Batch Configuration* you need to click on the batch wise *Submit* button.

2. After changing the setting from the *Batch configuration* all the batch graphs will be reset.

### 9.2.9 Report Configuration

The Report Configuration option in the tree-structure menu allows the operator to configure the Report for channels.

The Report Configure option is as follows. You have to select the channel from the list provided. Then specify the intervals at which the reports have to be generated and the data that should be included in the report. In the case of *Hourly* the report will be generated every hour. In the case of *Daily* it will be generated at the start of the everyday. *Monthly* will generate a report at the start of the every month. For *Annual* a report will be generated at the start of the every year. Also you may select the Data types such as Min. value, Max value, Peak value, Present value, Mean value and Sum while generating the report. If the 'Mean value' data type is not selected the 'Mean value' information will not be recorded while generating the report. Here to calculate the Peak or Mean or Sum value user must have to select the Minimum and Maximum value for a report. For more details see the Recorder side *Report Configuration*

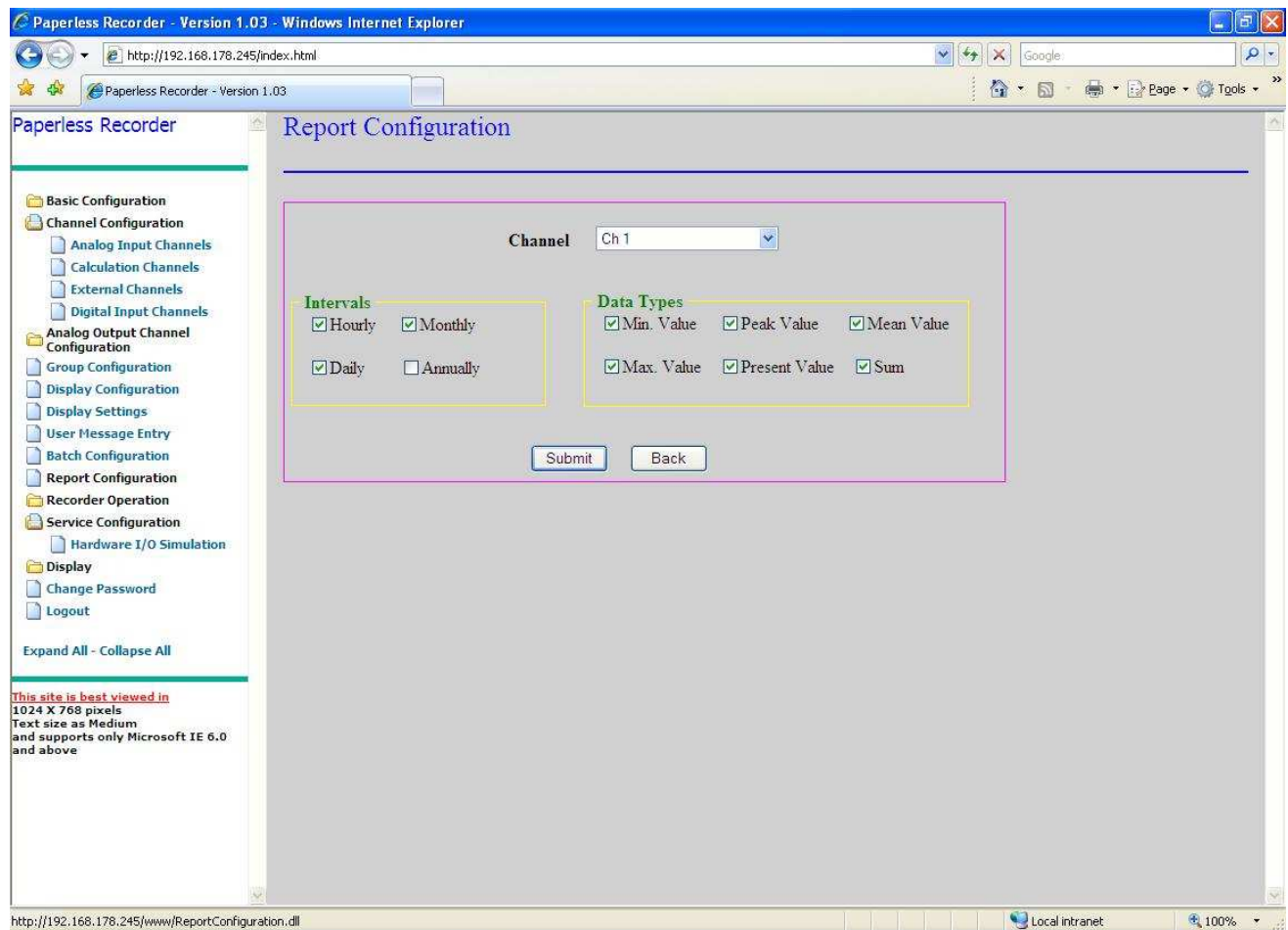

Figure 9. 422: Reporting Configuration

Note: To save the settings of the *Report configuration* you need to click on the channel wise *Submit* button.

## 9.2.10 Recorder Operation

### 9.2.10.1 Operations

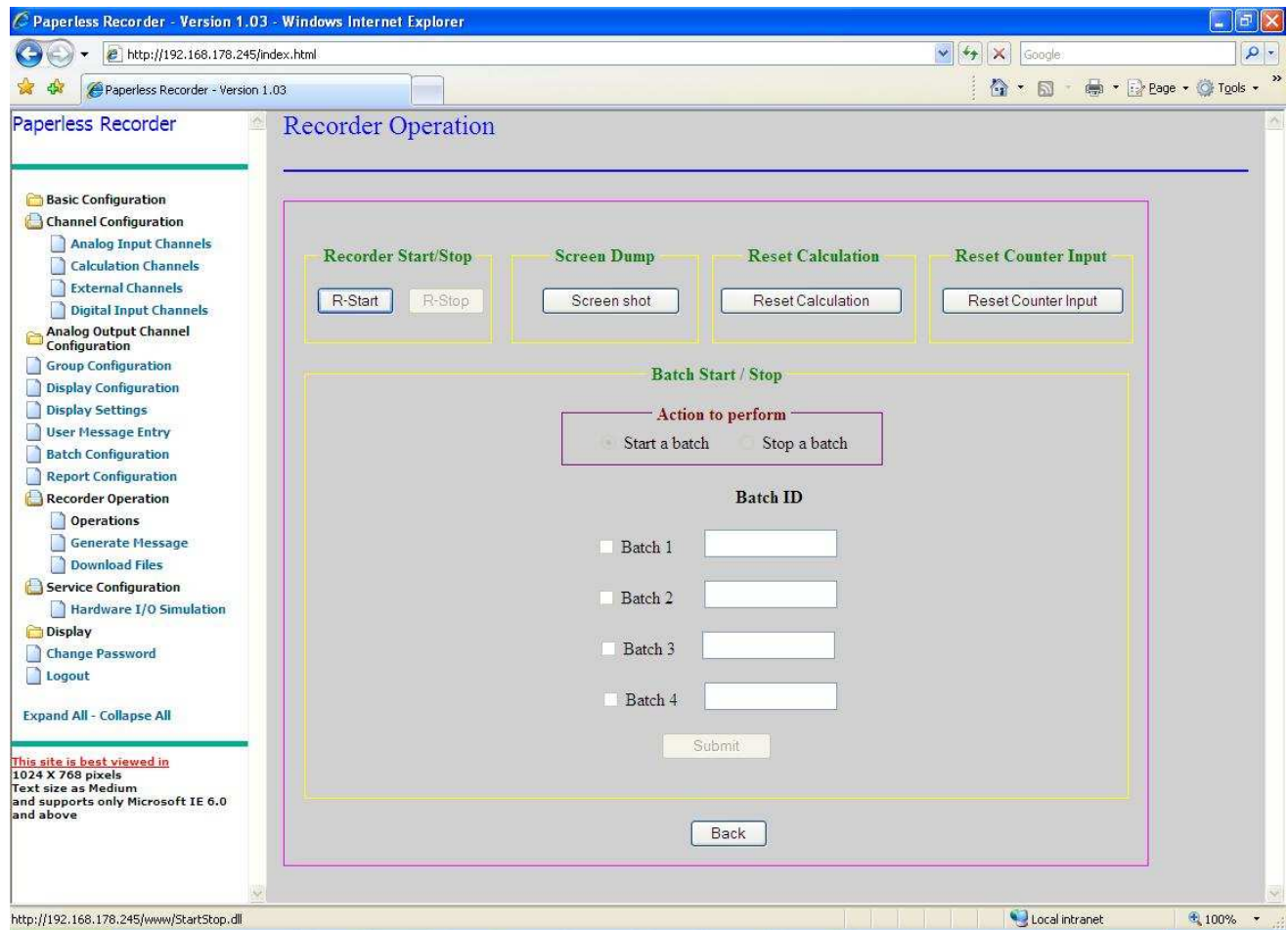

Figure 9. 433: Recorder Operation

This option provides the functionalities like '*Recorder start/stop*', '*Screen shot*', '*Reset calculation*', '*Reset Counter Input*', and '*Batch start/stop*'.

**Recorder start/stop:** "To start recording of a recorder, you have to select the R-Start button, after recording starts the following message will be displayed "You have successfully Started the

recording". To stop the recording you have to select the R-Stop button. After recording has been stopped the following message, will be displayed "You have successfully Stopped the recording"  
 Screen Shot: This option is used to capture the current screen of recorder. This is same as the Screen shot user key of the recorder.

**Reset Calculation:** This option will reset the calculation of signal processing. This is same as the recorder side Reset Calculation's user key.

**Reset Counter Input:** This option will reset the value of digital channel with input type as *Operating hours counter* if the digital channel is configured for the user keys.

**Batch Start/Stop:** This is used to start and stop batch recording. This is enabling only when recording is ON. To start or stop the batch recording you have to select the *Start a Batch* or *Stop a batch* radio buttons from the list and select the appropriate batch check box. If the batch ID, of a particular batch is configured for operator entry then the configured batch ID will display in the respective batch ID field. If you want to change then you may change it to any other number. The number entered should be between 1 and 1000. Then start the batch. Following image shows the *Batch Start/Stop* operation, here batch 4 is disabled and user is trying to start the batch 1,2 and 3.

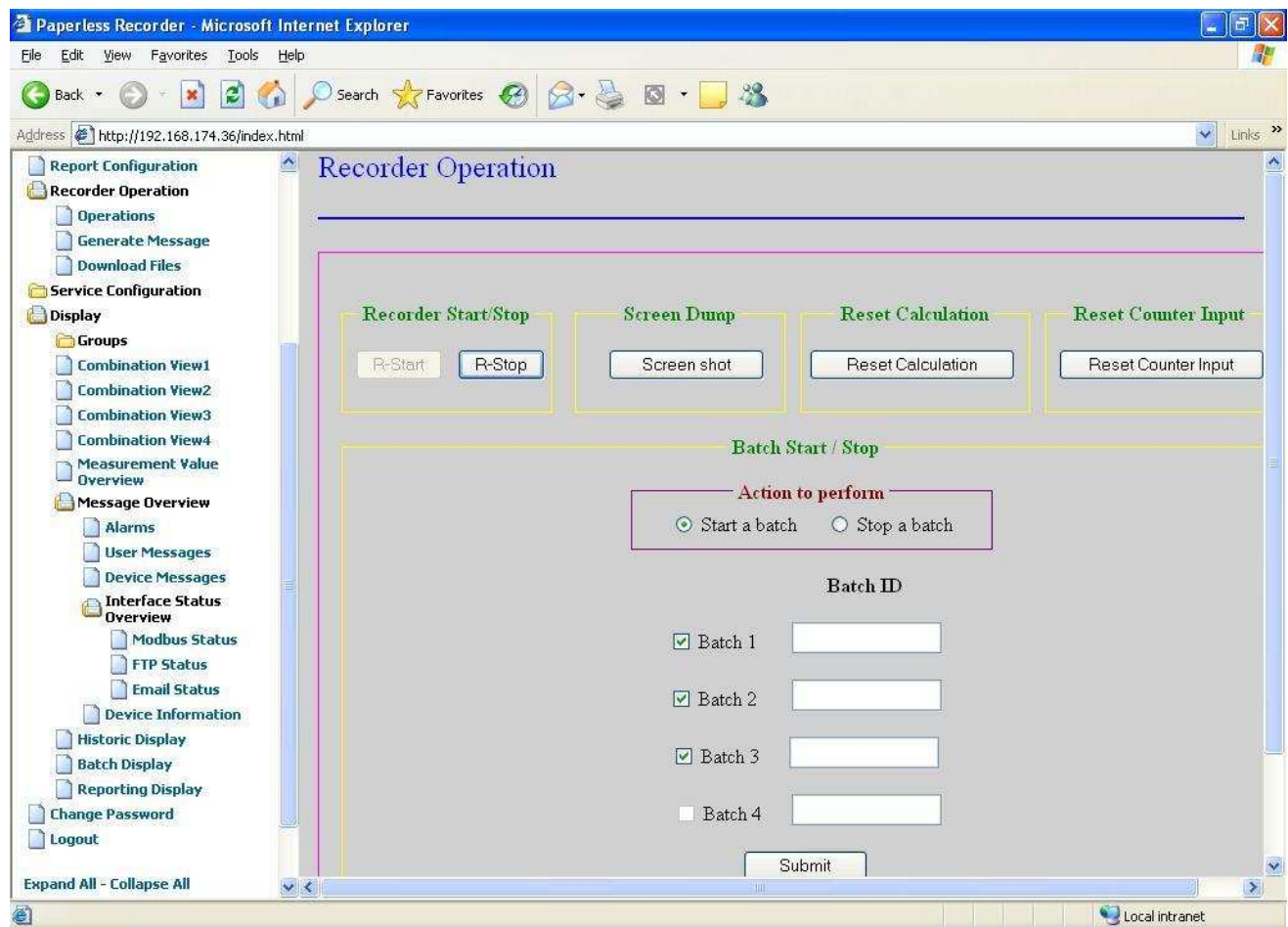

Figure 9. 444: Recorder Operation

### 9.2.10.2 Generate Message

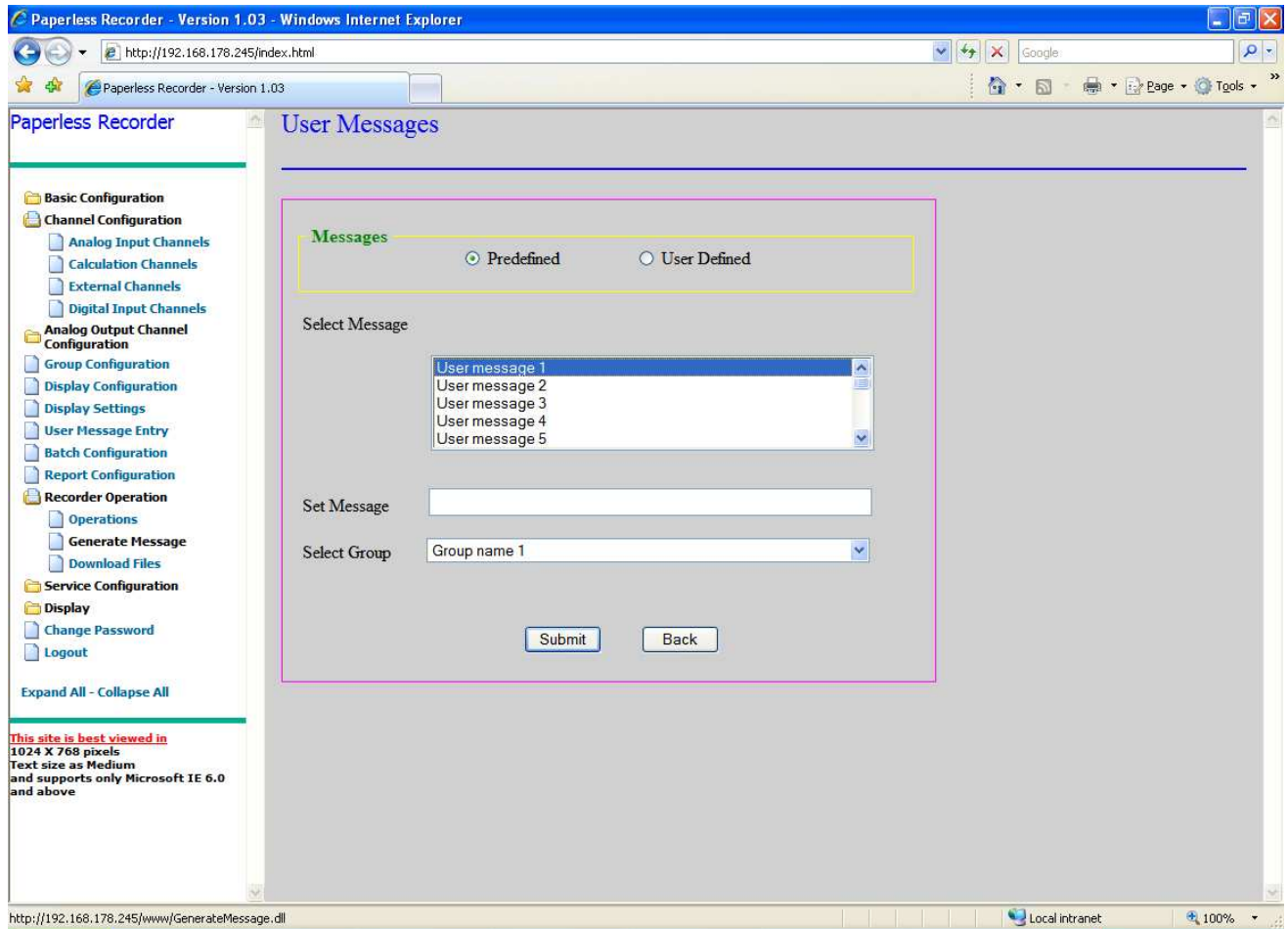

Figure 9. 455: Generate Message

By using this option you can enter the message while recording is 'ON'. Here you can select a predefined message, which has been set in *User Message entry* page, or you can enter new text message by selecting the User defined option. Also select the group associated with the message. This is same as the *User Message* at recorder side. The user messages will be logged in Display→Message Overview→User Messages.

### 9.2.10.3 Download Files

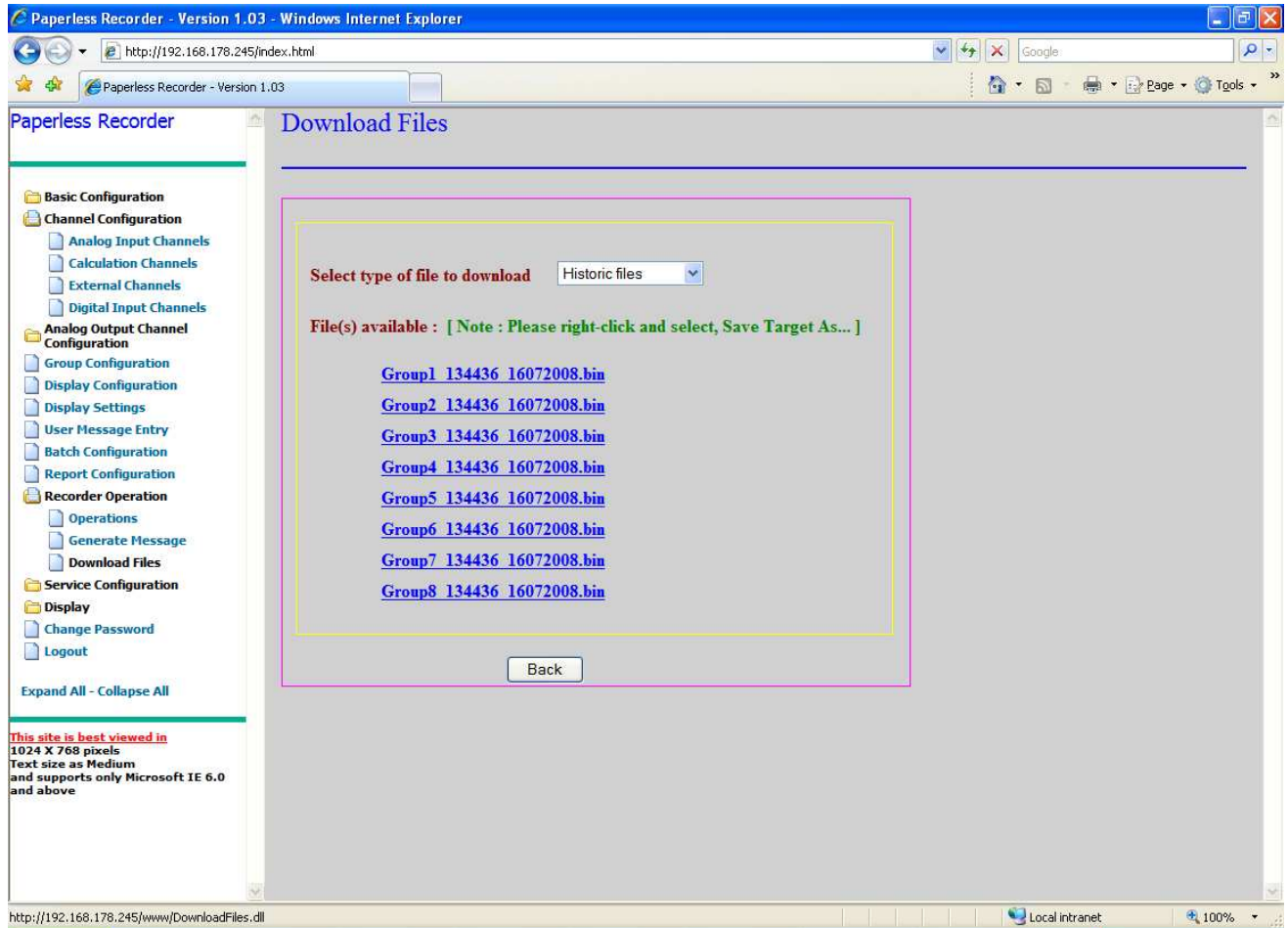

Figure 9. 466 Download Files

By using this option you can download the files from the recorder to the PC (client computer).

You can download Historic files, Batch files, Report files, Screenshot files, Configuration files and Software Tools. To download the files you have to right click on the file name and select the option “*Save Target As*” and give the path.

## 9.2.11 Service configuration

### 9.2.10.1 Hardware I/O Simulation

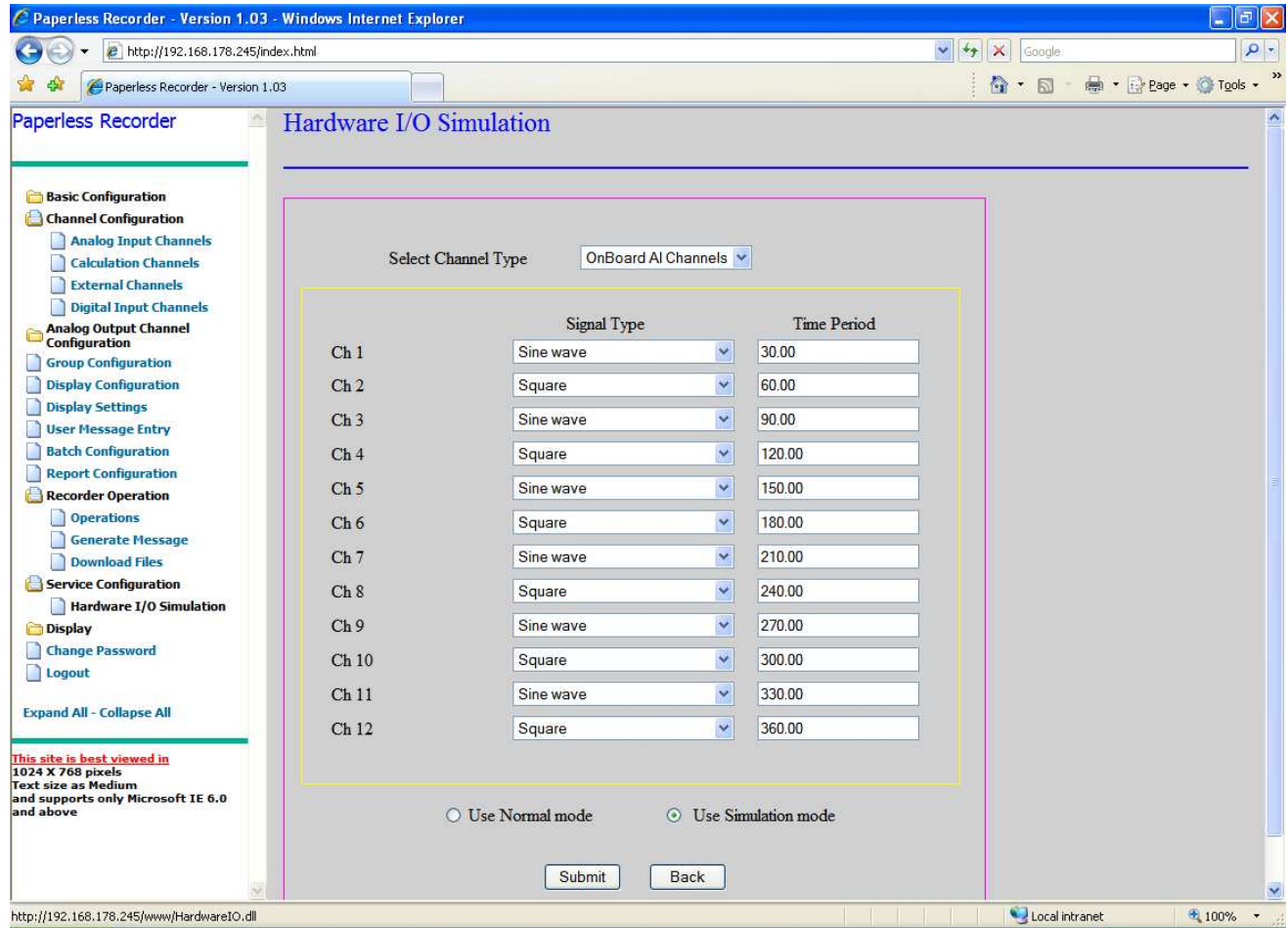

Figure 9. 477: Hardware I/O Simulation

You can configure the system for simulation mode, where all the channels (i.e. On-Board Analog Input, External and On-Board Digital Input Channels) are simulated by the system itself. You can configure each channel for a particular signal type such as sine wave, square wave, triangular wave etc. You can also specify the duty cycle (time period) for these signals. If you are selecting constant *Signal Type* (like 0.1xSpan (Constant)) then no need to give *Time Period* value.

The page display and selection of *Signal Type* for “OnBoard AI Channels” and “External Channels” *Channel Type* are similar.

If you select the “OnBoard DI Channels” *Channel Type* the page displayed will be as follows.

Here you can configure each channel for particular signal type such as Square, Square High and Square Low. You can also specify the *Time Period* for Square signal type. If you select Square High or Square Low then no need to give *Time Period* value. The range to be given for time period fields should be between 1 to 1000.

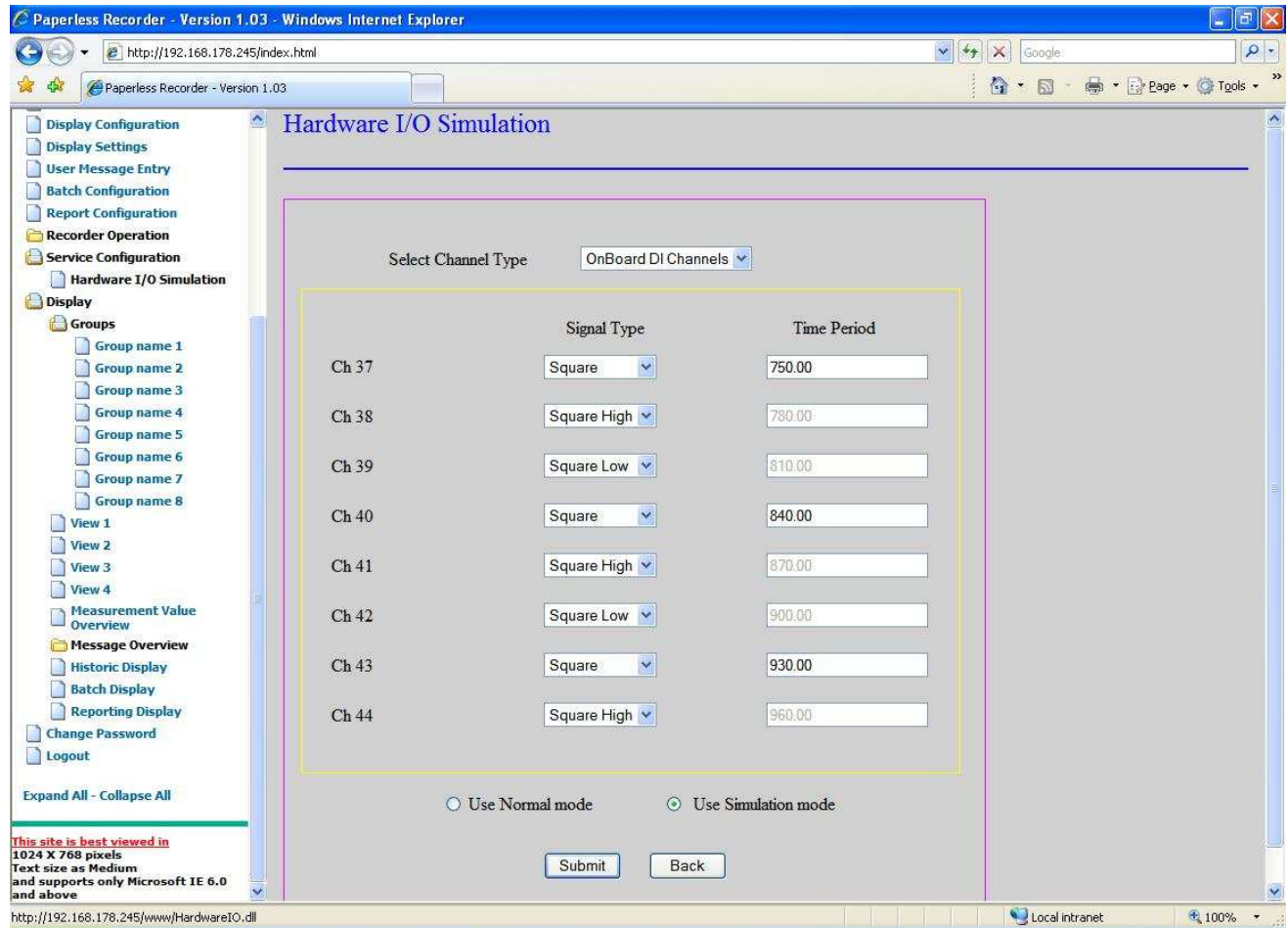

Figure 9. 488: Hardware I/O Simulation –OnBoard DI Channels

All the features of the system will also work in the simulation mode, except for the fact that the source of data is simulated internally.

The recorder can either work in simulation mode or in Normal mode.



## 9.2.11 Display

### 9.2.11.1 Groups

The user can switch to any of the configured group's graph display. In any of the modes you can view the live value of the channels, which is configured for the selected group as per the group configuration. The display is similar to recorders group display, with few changes. Markers, which are present in the group display of the recorder (if scale is enabled) is not displayed in the browser group display. There is no option to change the display type of the presently viewed group as user can use "Change display" user key in recorder. There is no option to hide and display scale and numeric values. Rest of the functionality is same as in recorder group display

While a group is being displayed on the browser, if Channel Configuration, Display Setting or Temperature is changed from the recorder or from any other browser then the display of the recorder and browser reset.

If selected group is 'OFF' (check Group functions, section 9.2.3), then the below screen will be displayed.

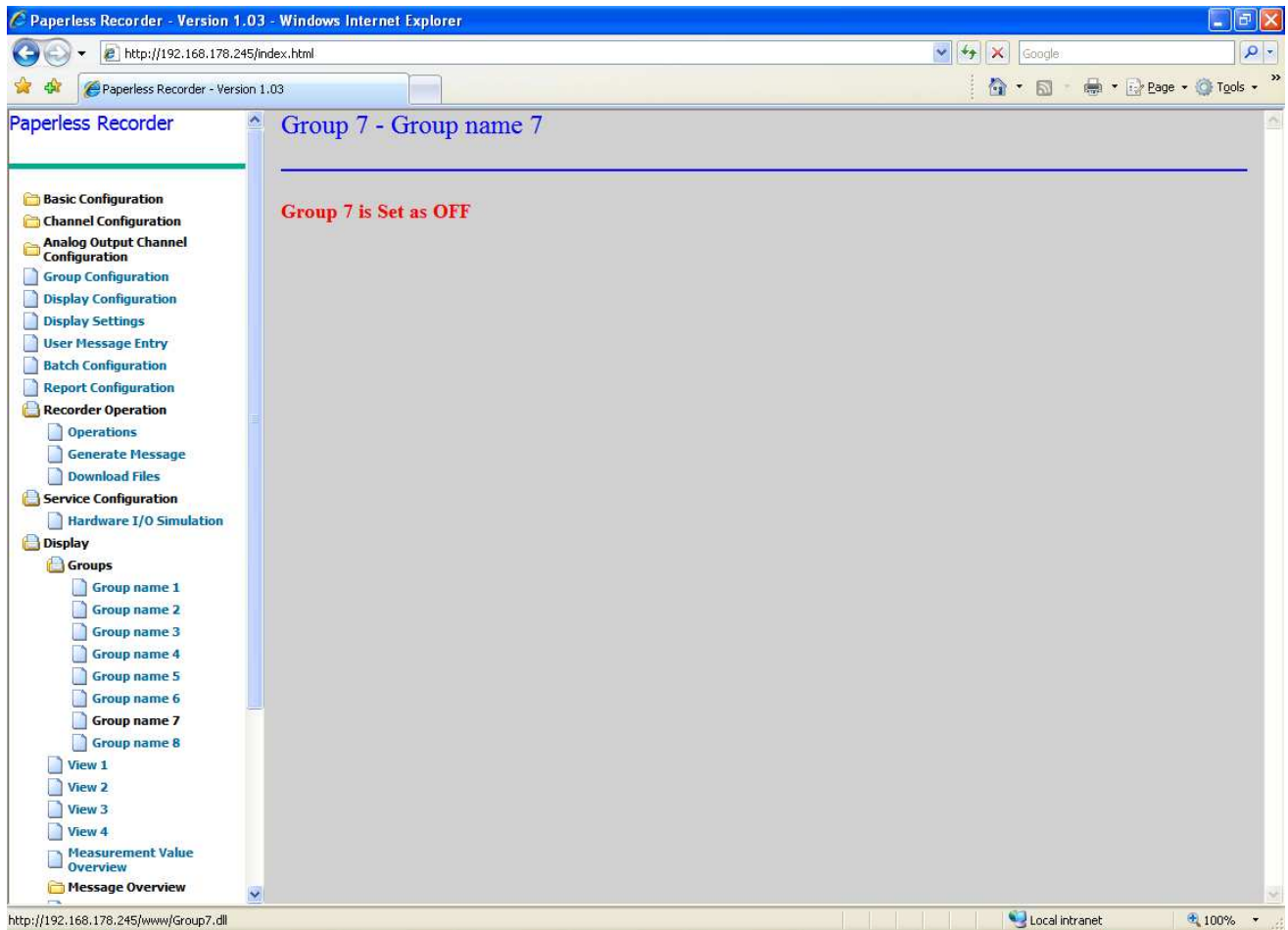

Figure 9. 499: Group Off

## Network Failure

If network goes down, a dialog will be displayed showing the time of network failure and the Graph will remain constant. Once the network connection is re-establish, display will plot the live values of channel for the group.

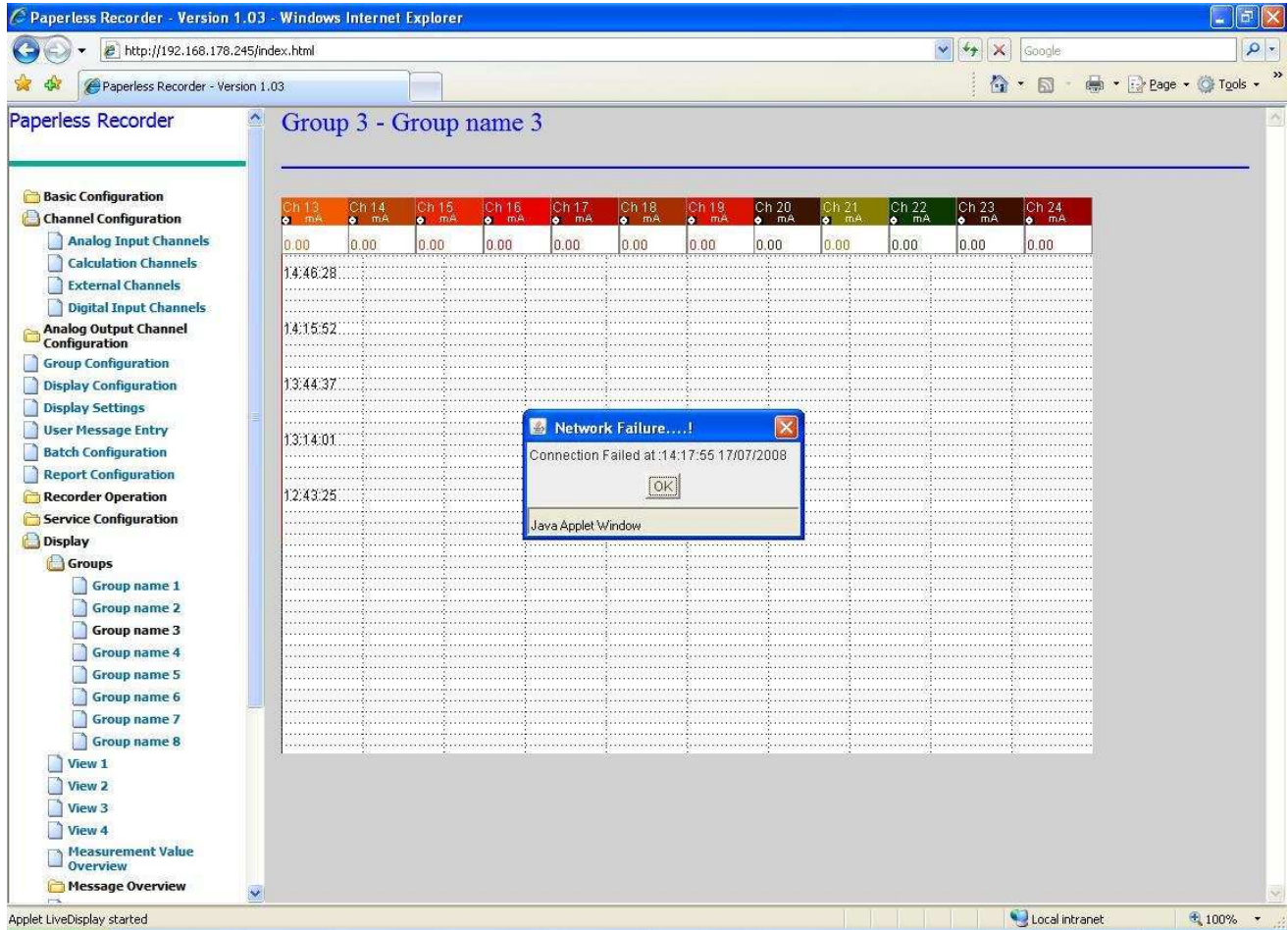







Figure 9. 60: Network Failure

## 1. Horizontal Trend Display

According to channel's color and the thickness specified, trend lines (graph lines) are plotted. In the graph below dashed lines in green, red, blue and yellow colors are the trip lines. The scales are plotted for channels that have scales enabled in their *Channel Configuration*. For two or more channels having the same unit and range only one scale will be plotted for all of them. According to the number of divisions set in the channel configuration, scale divisions are plotted. The first division (topmost) represents the upper limit and last division (bottom) represents the lower limit of the channel. Even if some value of channel is above the upper limit of the channel, it is plotted as the upper limit of channel. But its actual value will be displayed in the numeric display box of the

channel. Channel name, unit and channel values will be displayed in numeric display boxes. There are five icons to represent which value of the channel is being plotted.

Note: The graph display will scroll from right to left.

Value	Icon
Present value -	
Max value -	
Min value -	
Peak value -	
Mean -	

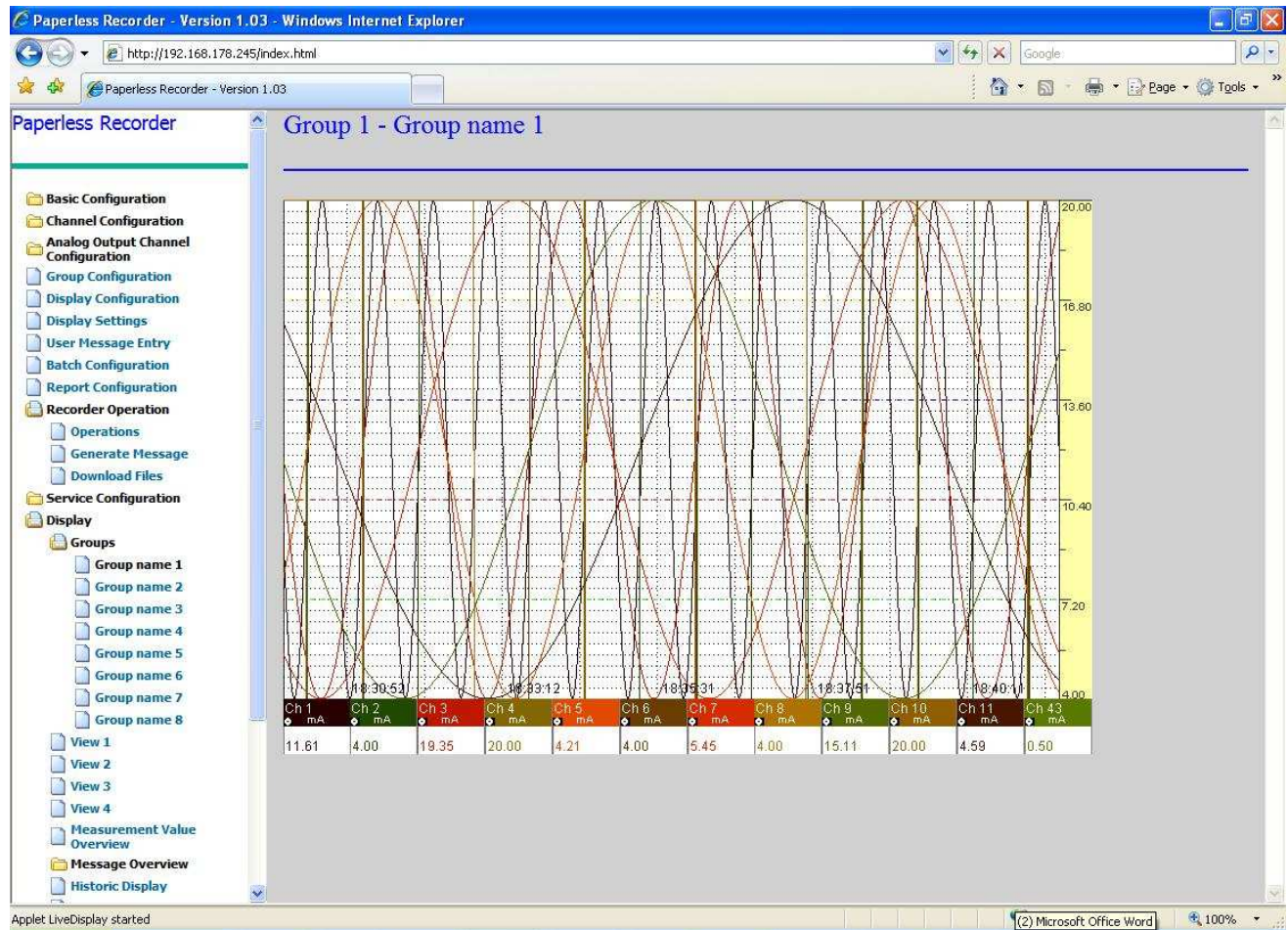

Figure 9. 61: Horizontal Trend

## 2.Vertical Trend Display

In Vertical Trend Display numeric display boxes representing channel values are displayed at the top of the graph and scales are displayed at the bottom of the graph. For vertical and horizontal trend display, if an alarm occurs for any of the channels then the corresponding numeric display box will be shown with a red background. The graph will scroll from top to bottom.

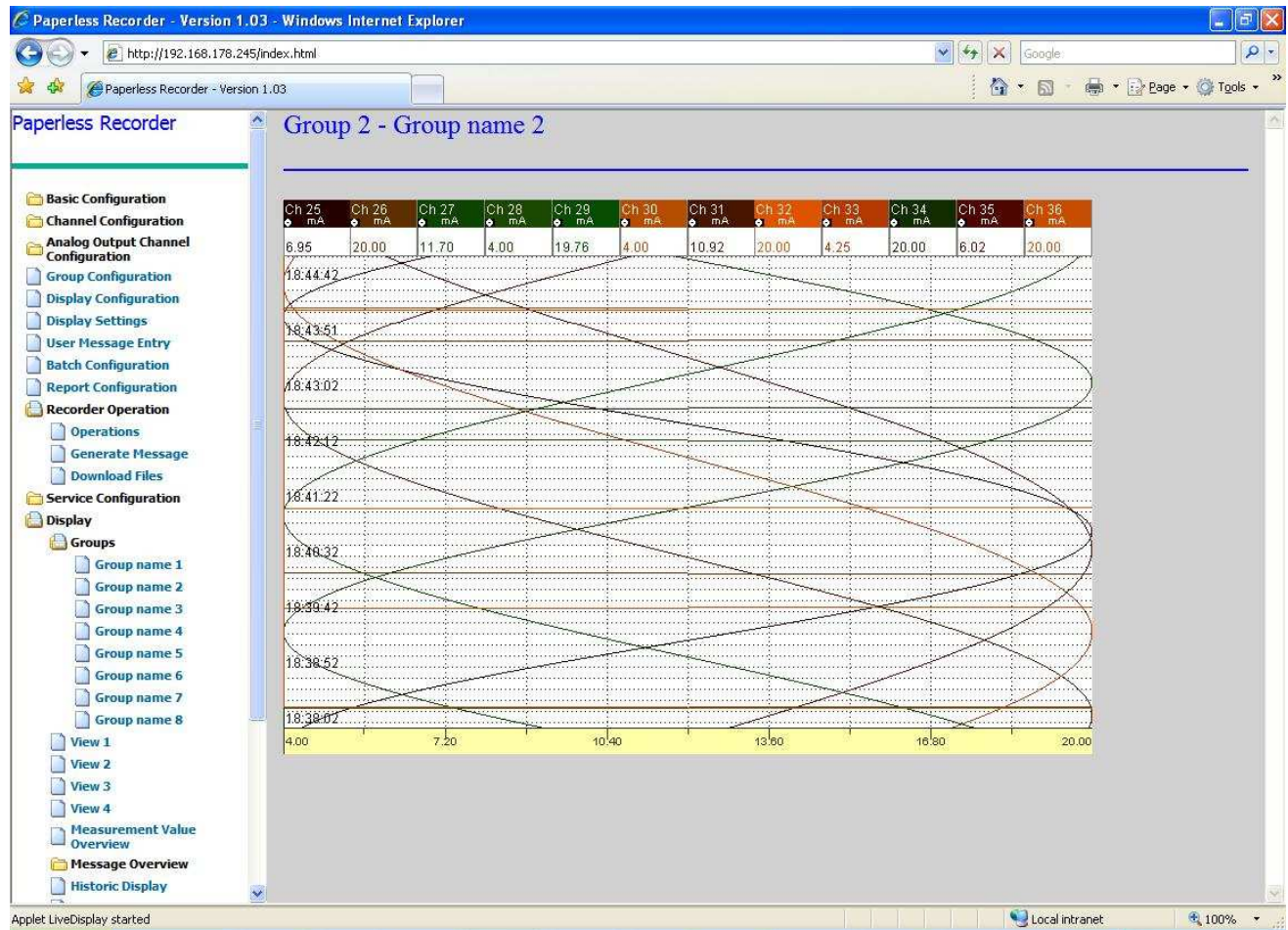

Figure 9. 62: Vertical Trend

### 3.Bar Graph

The Complete screen is divided according to the number of channels into equal sections. In each section a scale with divisions and a bar representing the channel values is plotted. The numeric value along with the channel's name & unit is displayed, similar to horizontal & vertical trend display. If an alarm occurs for any of the channels, then the corresponding numeric value will be having a red background.

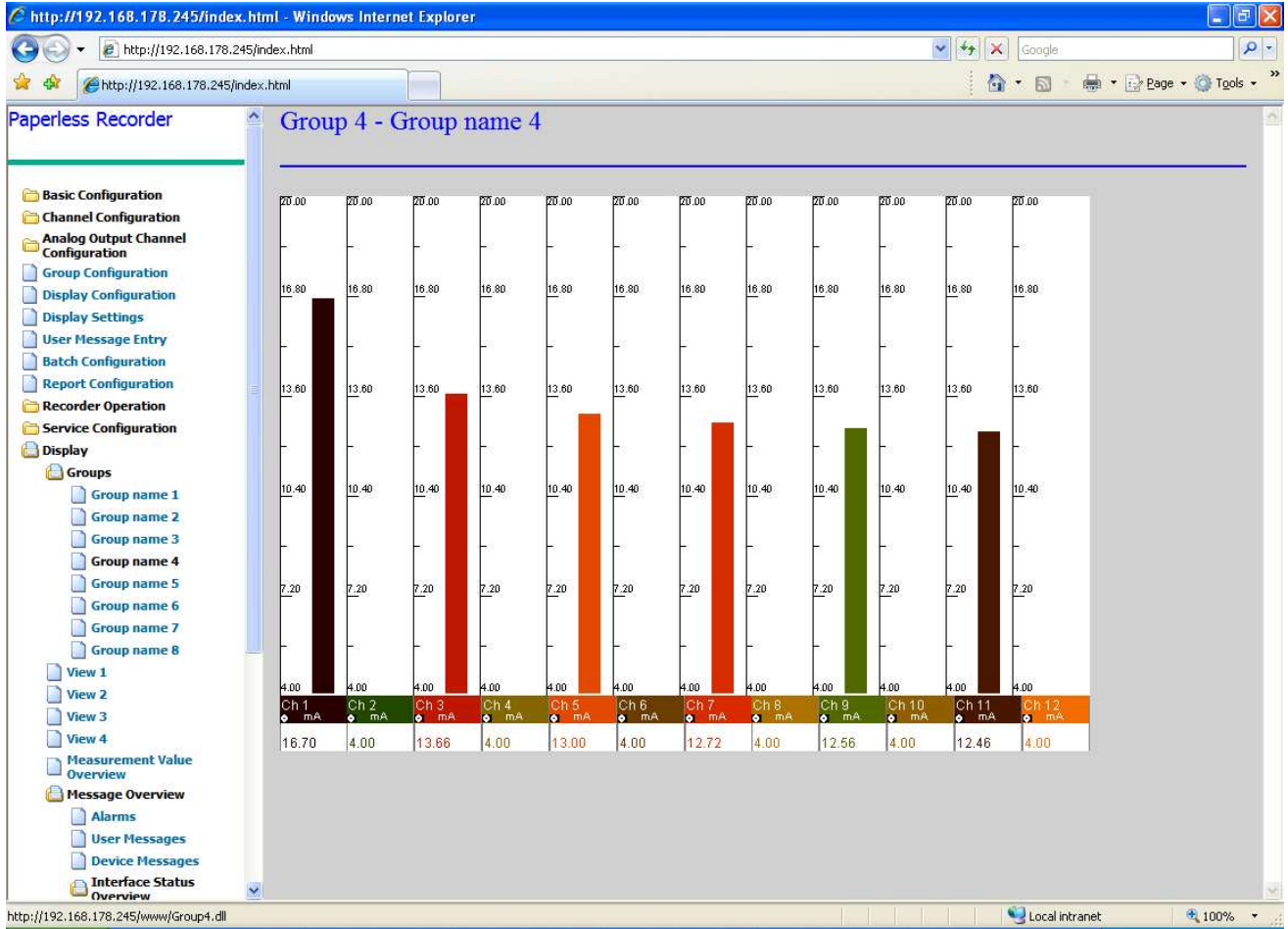

Figure 9. 6350: Bar Graph

4.Numeric Graph:

The channels configured in a group are displayed along with their units. If alarm for channel occurs then channel value will be displayed with red background.

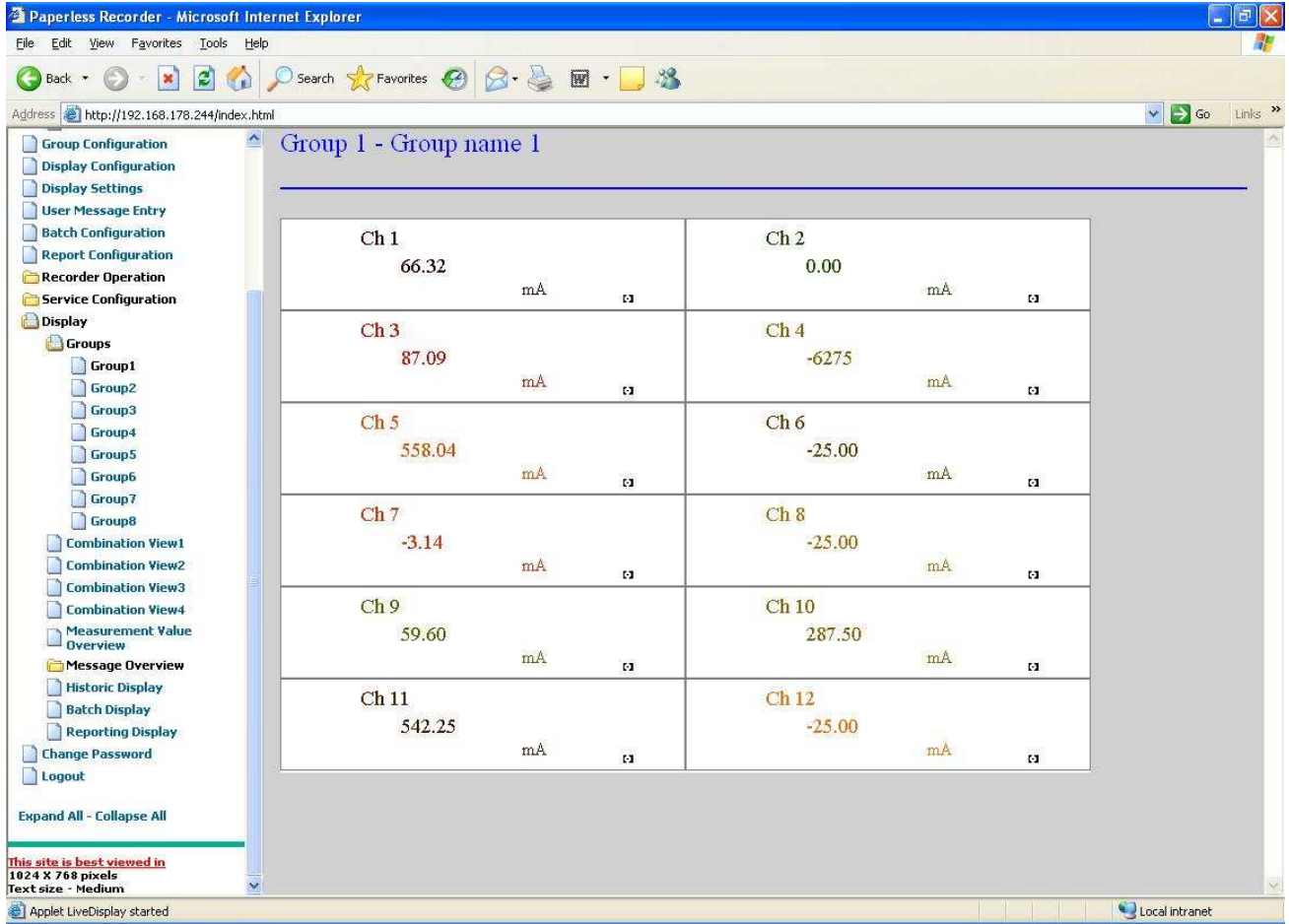

Figure 9.514: Numeric Display

If an alarm occurs for any of the channels then it is indicated by the red color, on that channel's numeric value as shown in the figure below.

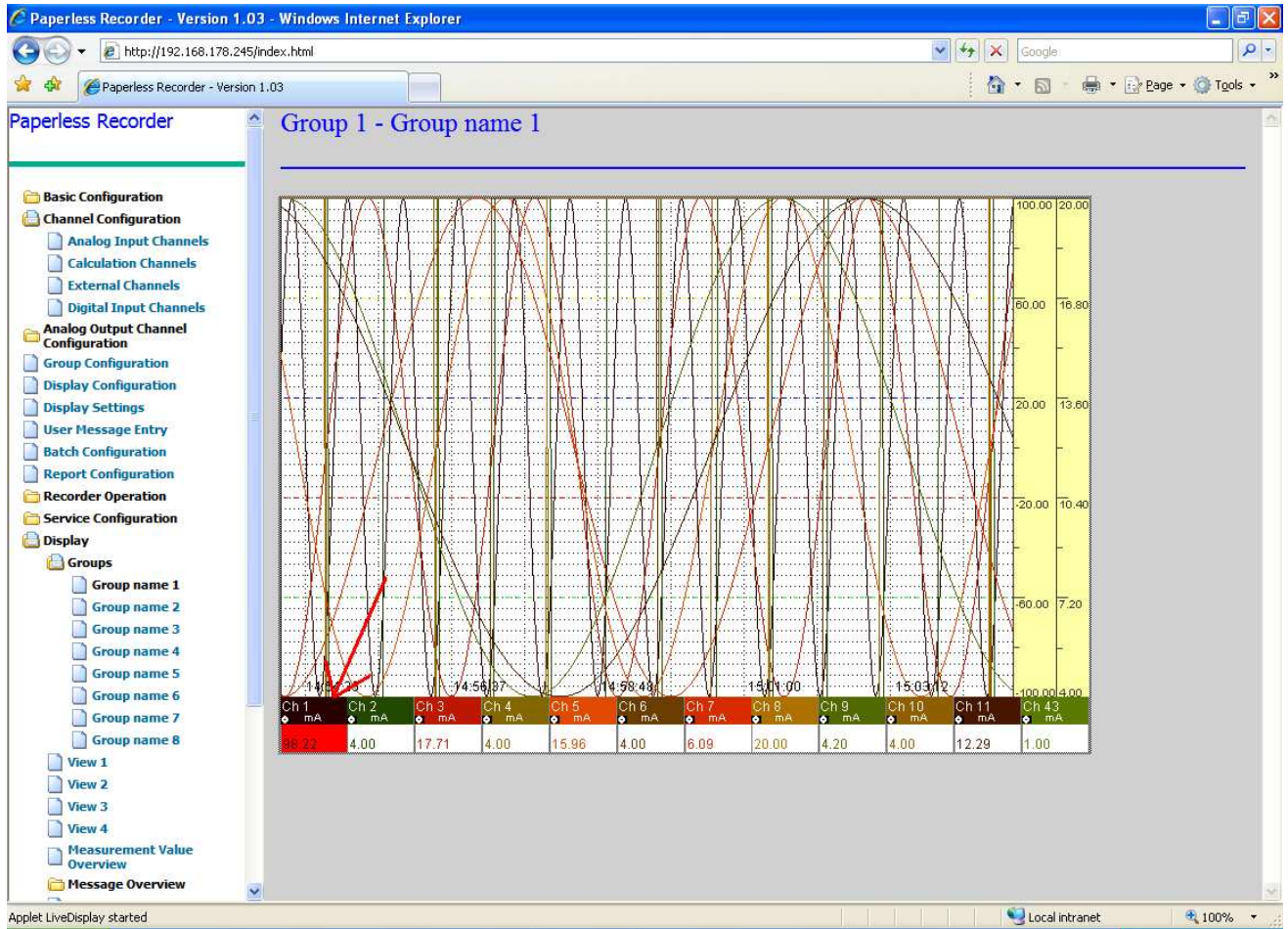

Figure 9. 525: Alarm indication

### 9.2.11.2 Combination View

Each combinational view can include 2 to 4 groups. These groups can be configured in Display configuration dialog (Refer 9.2.4). Groups will be positioned according to the selected Combinational view orientation.

Ex: If 2 groups are configured in Combinational view 1 with orientation as1 (left and right), then through display menu user can switch to Combinational View1 to view the 2 groups.



### 9.2.11.2.1 Combination View 1

Click *Combination View 1* from Display menu.

Ex: In the below fig, Combinational view 1 is configured as 2Groups with Left/ Right orientation.

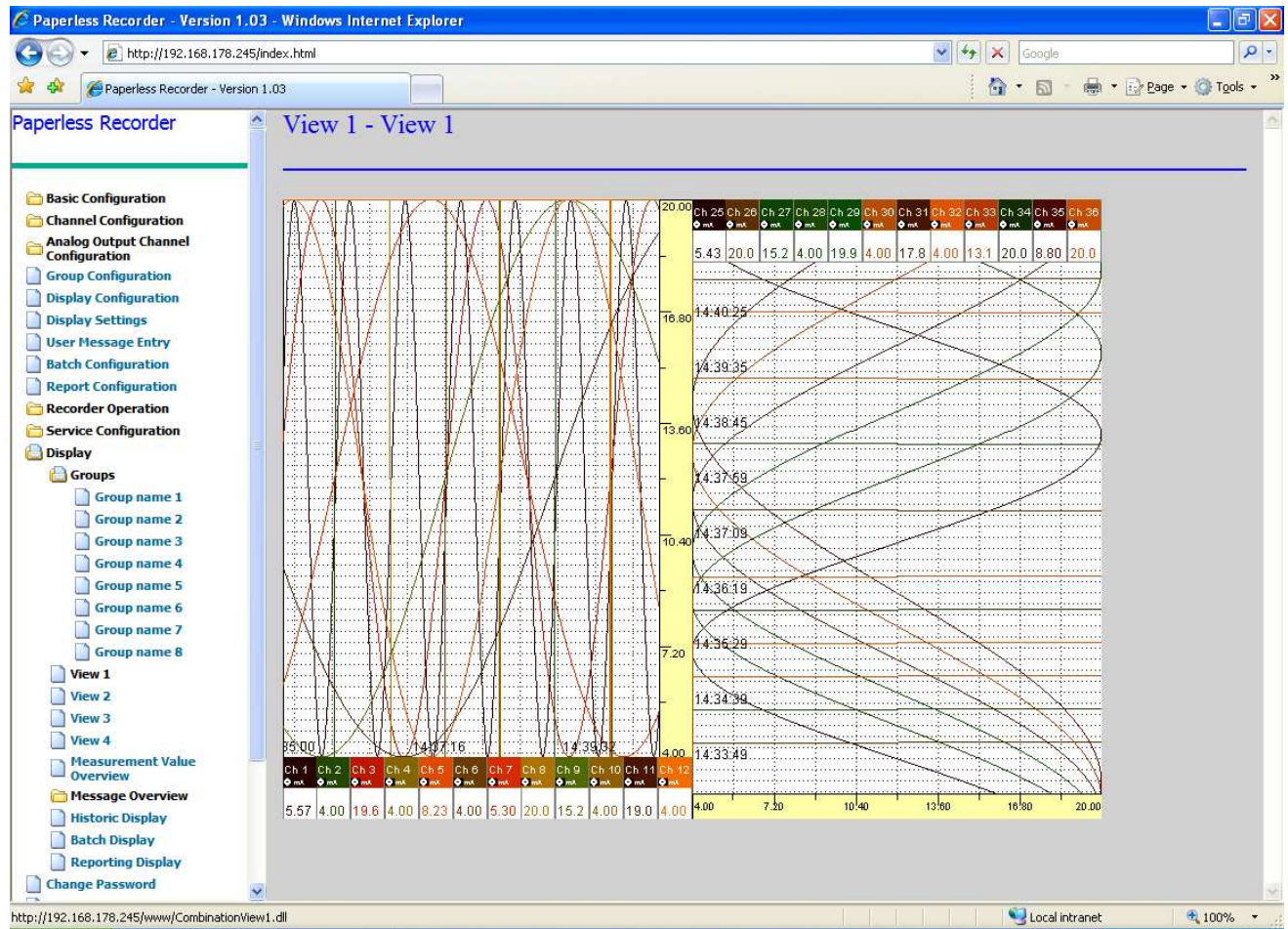

Figure 9. 536: Combination View 1

### 9.2.11.2.2 Combination View 2

Click *Combination View 2* form Display menu.

Ex: In the below fig, Combinational view 2 is configured as 3Groups orientation.

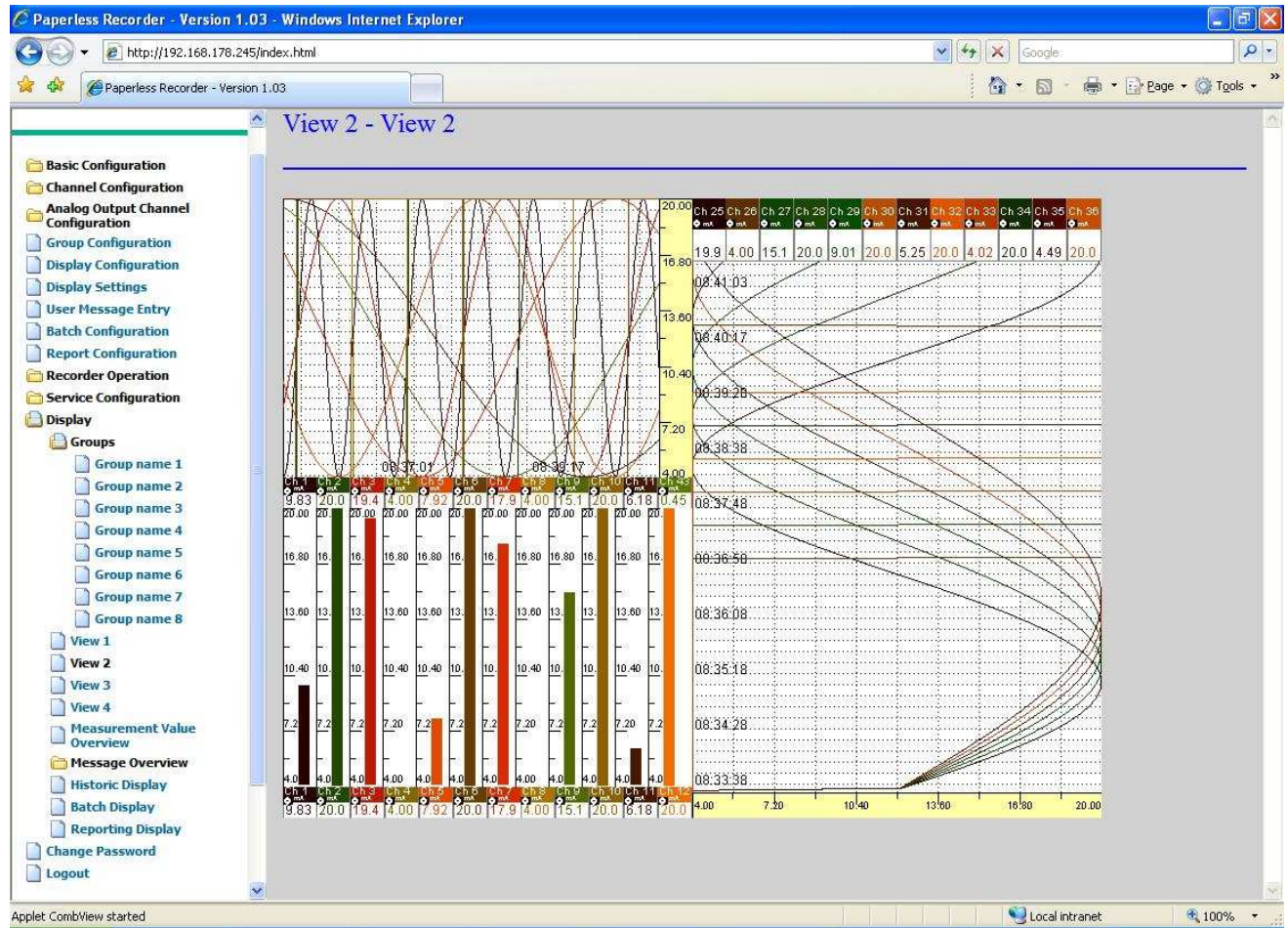

Figure 9. 547: Combination View 2

### 9.2.11.2.3. Combination View 3

Click *Combination View 3* form Display menu.

Ex: In the below fig, Combinational view 3 is configured as 2Groups with top & bottom orientation.

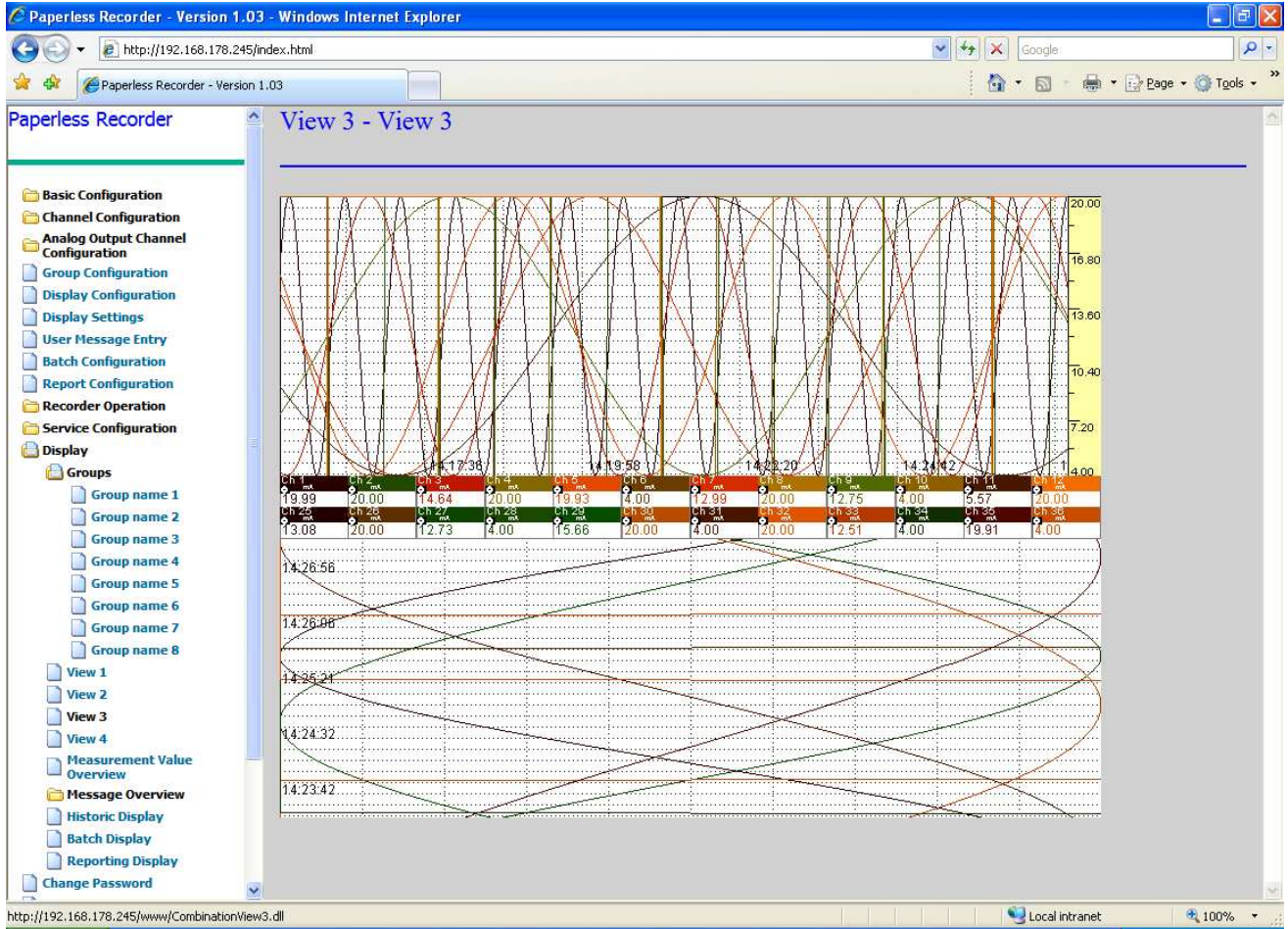

Figure 9. 558: Combination View 3

#### 9.2.11.2.4. Combination View 4

Click *Combination View 4* form Display menu.

Ex: In the below fig, Combinational view 4 is configured as 4Groups orientation.

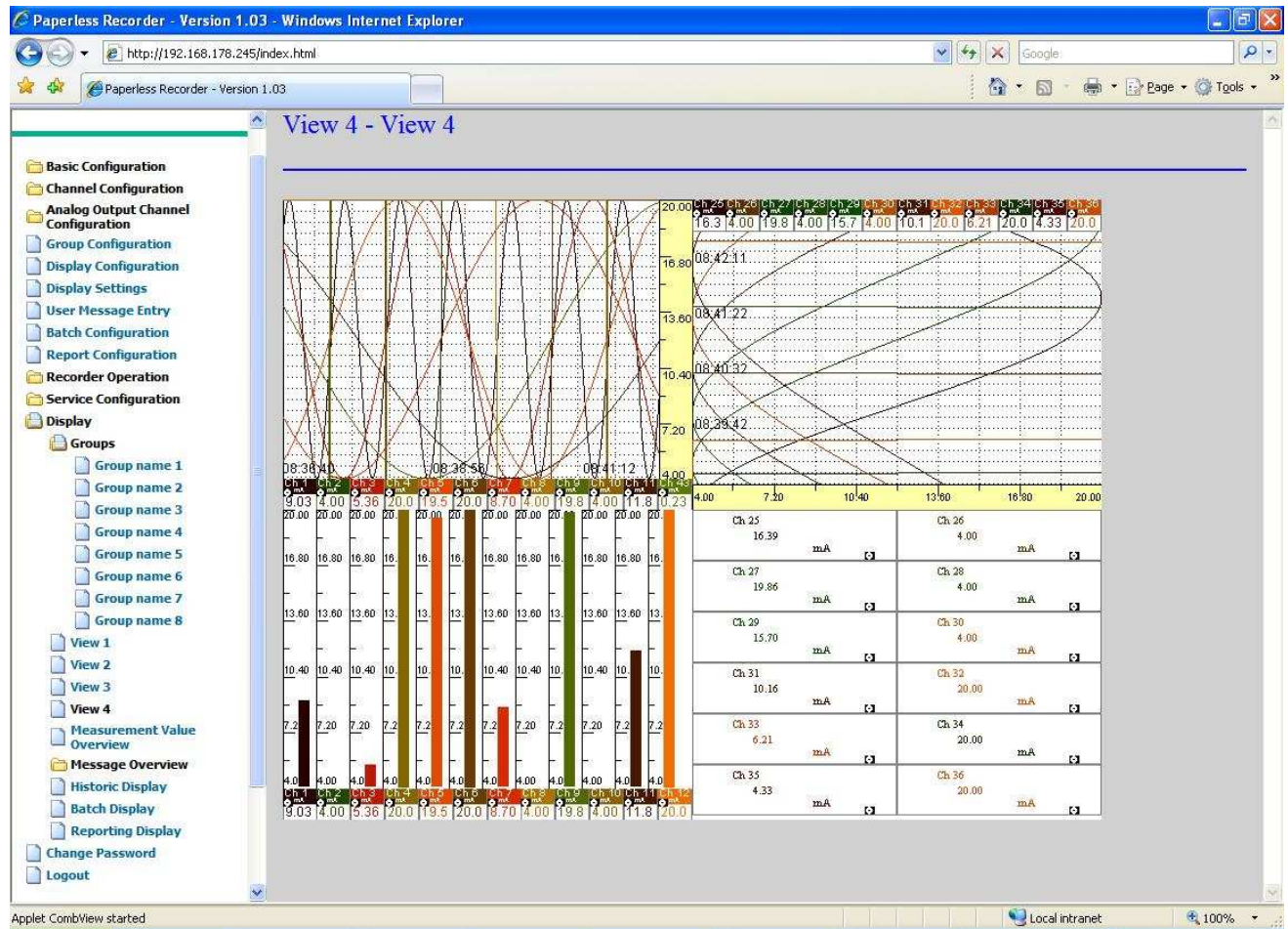

Figure 9. 569: Combination View 4

While combinational view is being displayed on the browser, if Channel Configuration, Group Configuration, Display Setting or Temperature is changed from recorder or from any other browser the display of the recorder and browser will be reset.

While any of the Combinational view is being displayed on browser, if Display Configuration is changed from the recorder or from some other browser then a message, as shown in figure below will be displayed. To view the combination-display you have to click on to the required view link under the Display menu.

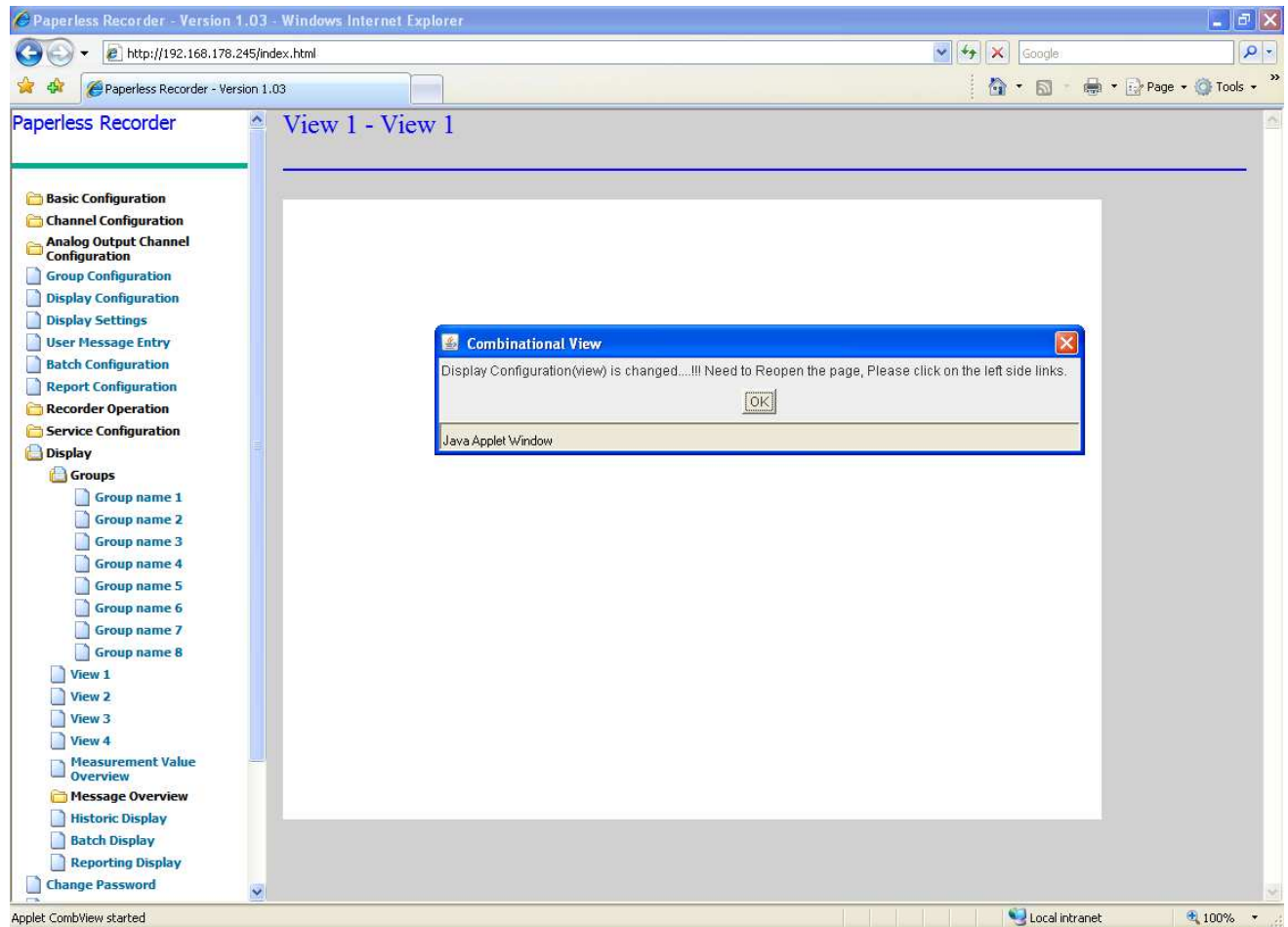

Figure 9. 70: Combination View

### 9.2.11.3. Measurement Value Overview

The measurement value overview displays only present (among available min, max, present, peak and mean) value of all the configured channels in the numeric form (refer below figure).

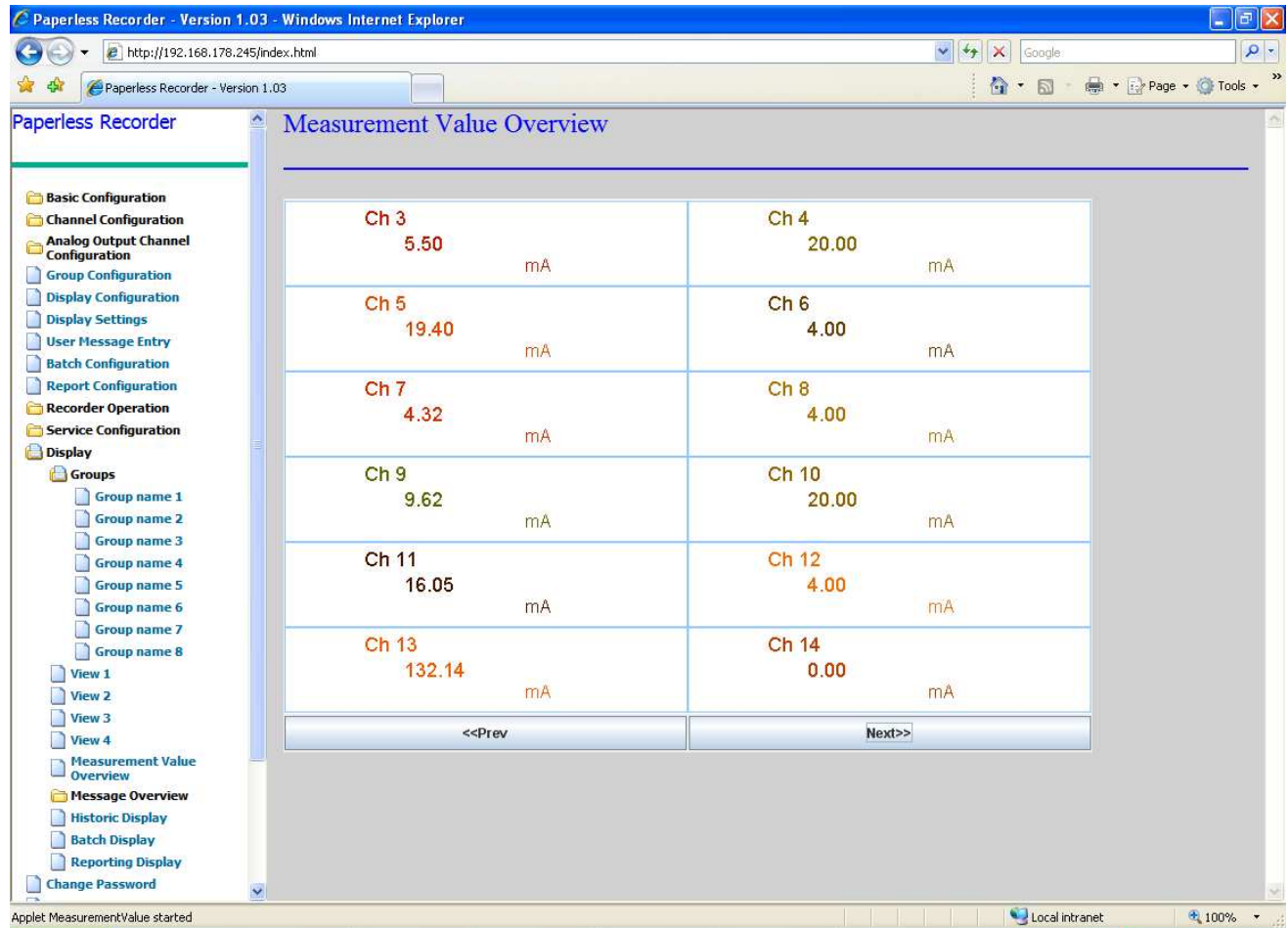

Figure 9. 71: Measurement value overview

You can view the values of 12 channels at a time. Press 'Next>>' button, to view the next two channels, if any are available. For example, if screen is displaying channels from 1 to 12, pressing 'Next>>' button will display channels from 3 to 14. The '<<Prev' button will display two previous channels. For example if screen is displaying channel from 13 to 24, then pressing '<<Prev' will display the channels form 11 to 22.

While browser is displaying Measurement Value, if Hardware I/O simulation is changed from normal mode to simulation mode or vice versa, or if changes are made in Channel configuration, Display Setting or Temperature from the recorder or from any other browser then the Displaying Measurement Value will be updated according to the new changes.

#### 9.2.11.4. Message Overview

The 'Message Overview' is present under the display menu option of the left side tree control and it consists of 'Alarms', 'User Messages', 'Device Messages', 'MODBUS status', 'FTP status', 'E-Mail status', and 'Device Information'. By selecting any one of these options the corresponding log will be displayed. A Maximum of 100 logs can be maintained in these log files.

### 9.2.11.4.1 Alarms Log

*Alarm logs* maintain a record of the last 100 alarm events to have occurred (alarm start and stop are maintained as separate events). Alarm logs provide the following information:

*Channel:* The channel name, for which the alarm started/stopped.

*Alarm Type:* High Alarm, Low Alarm or Gradient Alarm.

*Alarm Time:* Start/Stop time of the alarm *Status:* It tells if this log entry is corresponding to the start of an alarm or the stop of an alarm.

*Alarm description:* If some alarm description was provided while configuring that particular alarm. The description is shown in the box at the bottom of the dialog, for the alarm selected in the list of log entries. Following figure shows the list of *Alarm log*

Sr.No.	Channel Name	Alarm Type	Alarm Start Date	Status	Al
1	OnBoard Channel 1	High	03:04:09 06/03/04	Started	
2	OnBoard Channel 1	High	12:53:14 05/03/04	Started	
3	OnBoard Channel 1	High	12:51:36 05/03/04	Started	
4	OnBoard Channel 1	High	12:46:54 05/03/04	Started	
5	OnBoard Channel 1	High	12:40:50 05/03/04	Started	
6	OnBoard Channel 1	High	12:39:18 05/03/04	Started	
7	OnBoard Channel 1	High	12:38:24 05/03/04	Started	

Figure 9.72: Alarm Log

### 9.2.11.4.2 User Messages Entry

The *User Messages log* provides information such as the user messages that have been set, the time at which it was set and the groups with which the messages were associated. The most recent entries into the log file will be displayed on the top of the list. The oldest entry will be the one displayed at the end of the list. The user message log shall have up to a 100 entries.

This report shows the information in the form of Sr. No., *User Message* i.e. message , *Time Entry* i.e. the time at which message is entered , *Group* i.e. to which group message is entered.

Sr.No.	User Message	Time of Entry	Group
1	Wrong display	10:58:18 06/03/2004	Group
2	User message 15	10:57:20 06/03/2004	Group
3	Temperature is showing wrong	10:57:07 06/03/2004	Group
4	Current is showing wrong	10:56:47 06/03/2004	Group
5	Voltage is correct	10:56:28 06/03/2004	Group
6	User message 5	10:55:28 06/03/2004	Group
7	User message 1	10:54:59 06/03/2004	Group
8	Test Message from browser module	10:54:49 06/03/2004	Group
9	Browser Module	10:54:29 06/03/2004	Group
10	hi	12:59:47 05/03/04	Group

Figure 9. 7357: User Message Log

### 9.2.11.4.3. Device Messages

The *Device message log* provides important changes information related to the devices such as the Recorder Power On, Recording started, Recording stopped, Screensaver won't work, for any Sensor break value, IP address change etc. This report shows the information in the form of Sr. No., Action performed i.e. message and Time entry of the message.



Sr. No.	Action Performed	Time of Entry
1	Screen saver won't work.	14:08:23 17/07/2008
2	External Channel 12 Sensor Break!	12:09:07 17/07/2008
3	External Channel 10 Sensor Break!	12:09:07 17/07/2008
4	External Channel 8 Sensor Break!	12:09:07 17/07/2008
5	External Channel 6 Sensor Break!	12:09:07 17/07/2008
6	External Channel 4 Sensor Break!	12:09:07 17/07/2008
7	External Channel 2 Sensor Break!	12:09:07 17/07/2008
8	Screen saver won't work.	12:09:06 17/07/2008
9	Recorder power On	12:08:56 17/07/2008
10	External Channel 12 Sensor Break!	11:17:52 17/07/2008
11	External Channel 10 Sensor Break!	11:17:52 17/07/2008
12	External Channel 8 Sensor Break!	11:17:52 17/07/2008
13	External Channel 6 Sensor Break!	11:17:52 17/07/2008
14	External Channel 4 Sensor Break!	11:17:52 17/07/2008
15	External Channel 2 Sensor Break!	11:17:52 17/07/2008
16	Screen saver won't work.	11:17:51 17/07/2008
17	Recorder power On	11:17:41 17/07/2008
18	External Channel 12 Sensor Break!	10:33:30 17/07/2008
19	External Channel 10 Sensor Break!	10:33:30 17/07/2008
20	External Channel 8 Sensor Break!	10:33:30 17/07/2008
21	External Channel 6 Sensor Break!	10:33:30 17/07/2008
22	External Channel 4 Sensor Break!	10:33:30 17/07/2008
23	External Channel 2 Sensor Break!	10:33:29 17/07/2008
24	Screen saver won't work.	10:33:29 17/07/2008
25	Recorder power On	10:33:19 17/07/2008
26	External Channel 12 Sensor Break!	10:23:16 17/07/2008
27	External Channel 10 Sensor Break!	10:23:16 17/07/2008
28	External Channel 8 Sensor Break!	10:23:16 17/07/2008
29	External Channel 6 Sensor Break!	10:23:16 17/07/2008
30	External Channel 4 Sensor Break!	10:23:16 17/07/2008
31	External Channel 2 Sensor Break!	10:23:15 17/07/2008

Figure 9. 74: Device Message Log

#### 9.2.11.4.4. Interface Status Overview

##### 9.2.11.4.4.1. MODBUS Status

*MODBUS Status Log* shows the last 100 logs for status of each of the available On-Board channels and External channels

First column shows the Sr. No., Second column shows *Channel Name*. Third column shows *Status* of the corresponding channel, i.e. *Failed* if communication with the corresponding slave failed, and *Success* if communication with the corresponding slave is successful. Fourth column shows the *Slave Address* of the corresponding channel. Fifth column shows *Parameter Address* (register address) of the process value variable of the corresponding channel. Sixth column provides the *Entry time* of log for the corresponding channel. Logs are generated as soon as a communication event (communication breakup or recovery) occurs.

Sr.No.	Channel Name	Status	Slave Address	Parameter Address	End Time
1	External Channel 12	Failed	1	0	10:44:08
2	External Channel 10	Failed	1	0	10:44:08
3	External Channel 8	Failed	1	0	10:44:08
4	External Channel 6	Failed	1	0	10:44:08
5	External Channel 4	Failed	1	0	10:44:08
6	External Channel 2	Failed	1	0	10:44:08
7	External Channel 12	Success	1	0	10:43:58
8	External Channel 10	Success	1	0	10:43:58
9	External Channel 8	Success	1	0	10:43:58
10	External Channel 6	Success	1	0	10:43:58
11	External Channel 4	Success	1	0	10:43:58
12	External Channel 2	Success	1	0	10:43:58
13	External Channel 12	Failed	1	0	10:42:18
14	External Channel 10	Failed	1	0	10:42:18
15	External Channel 8	Failed	1	0	10:42:18
16	External Channel 6	Failed	1	0	10:42:18
17	External Channel 4	Failed	1	0	10:42:18
18	External Channel 2	Failed	1	0	10:42:18
19	External Channel 12	Success	1	0	10:42:08
20	External Channel 10	Success	1	0	10:42:08
21	External Channel 8	Success	1	0	10:42:08
22	External Channel 6	Success	1	0	10:42:08
23	External Channel 4	Success	1	0	10:42:08
24	External Channel 2	Success	1	0	10:42:08

Figure 9. 75: MODBUS Status

#### 9.2.11.4.4.2. FTP Status

The FTP Status displays the following: -

- Sr. No.
- Time at which the FTP was done.
- Status indicating success or failure.
- Error code and its corresponding description.
- File name that has been transferred.
- FTP Server address to which the files were uploaded.

The screenshot shows the 'FTP Status Log' page in the Paperless Recorder web interface. The table below represents the data displayed in the log.

Sr. No.	Entry Time	Error Code	File Server	Status	File Name	Error Code
1	09-24:10 17/07/2008	0	192.168.178.9	Success	Group8_134436_16072008.bin	Success
2	09-24:10 17/07/2008	0	192.168.178.9	Success	Group7_134436_16072008.bin	Success
3	09-24:09 17/07/2008	0	192.168.178.9	Success	Group6_134436_16072008.bin	Success
4	09-24:08 17/07/2008	0	192.168.178.9	Success	Group5_134436_16072008.bin	Success
5	09-24:07 17/07/2008	0	192.168.178.9	Success	Group4_134436_16072008.bin	Success
6	09-24:07 17/07/2008	0	192.168.178.9	Success	Group3_134436_16072008.bin	Success
7	09-24:06 17/07/2008	0	192.168.178.9	Success	Group2_134436_16072008.bin	Success
8	09-24:05 17/07/2008	0	192.168.178.9	Success	Group1_134436_16072008.bin	Success
9	09-22:21 17/07/2008	12003	192.168.178.9	Failed	Group8_134436_16072008.bin	Exceeded storage
10	09-22:21 17/07/2008	12003	192.168.178.9	Failed	Group7_134436_16072008.bin	Exceeded storage
11	09-22:21 17/07/2008	12003	192.168.178.9	Failed	Group6_134436_16072008.bin	Exceeded storage
12	09-22:21 17/07/2008	12003	192.168.178.9	Failed	Group5_134436_16072008.bin	Exceeded storage
13	09-22:21 17/07/2008	12003	192.168.178.9	Failed	Group4_134436_16072008.bin	Exceeded storage
14	09-22:21 17/07/2008	12003	192.168.178.9	Failed	Group3_134436_16072008.bin	Exceeded storage
15	09-22:21 17/07/2008	12003	192.168.178.9	Failed	Group2_134436_16072008.bin	Exceeded storage
16	09-22:20 17/07/2008	12003	192.168.178.9	Failed	Group1_134436_16072008.bin	Exceeded storage

Figure 9. 586: FTP Status

### 9.2.11.4.4.3. Email Status

The Email Status displays the following information: -

- Sr. No.
- Time at which the Email was done.
- Status indicating success or failure.
- Files that have been sent as attachments.
- Email addresses of the recipients.

The screenshot shows the 'Email Status Log' page in a web browser. The browser title is 'Paperless Recorder - Version 1.03 - Windows Internet Explorer'. The address bar shows 'http://192.168.178.245/index.html'. The left navigation menu includes options like 'Group Configuration', 'Display Configuration', 'User Message Entry', 'Batch Configuration', 'Report Configuration', 'Recorder Operation', 'Service Configuration', 'Display', 'Groups', 'Measurement Value Overview', 'Message Overview', 'Alarms', 'User Messages', 'Device Messages', 'Interface Status Overview', 'Modbus Status', 'FTP Status', 'Email Status', 'Device Information', 'Historic Display', 'Batch Display', 'Reporting Display', 'Change Password', and 'Logout'. The main content area displays a table with the following data:

Sr.No.	Entry Time	Email Address	Status	File Name
1	09:29:19 17/07/2008	radhika.hs@Intemsys.com	Success	09_29_00_17_07_2008_Recorder.jpg
2	09:29:19 17/07/2008	radhika.hs@Intemsys.com	Success	09_28_06_17_07_2008_Recorder.jpg
3	09:29:19 17/07/2008	radhika.hs@Intemsys.com	Success	09_27_58_17_07_2008_Recorder.jpg
4	09:29:19 17/07/2008	radhika.hs@Intemsys.com	Success	09_23_48_17_07_2008_Recorder.jpg
5	09:27:40 17/07/2008	radhika.hs@Intemsys.com	Success	Group8_134436_16072008.bin
6	09:27:40 17/07/2008	radhika.hs@Intemsys.com	Success	Group7_134436_16072008.bin
7	09:27:40 17/07/2008	radhika.hs@Intemsys.com	Success	Group6_134436_16072008.bin
8	09:27:40 17/07/2008	radhika.hs@Intemsys.com	Success	Group5_134436_16072008.bin
9	09:27:40 17/07/2008	radhika.hs@Intemsys.com	Success	Group4_134436_16072008.bin
10	09:27:40 17/07/2008	radhika.hs@Intemsys.com	Success	Group3_134436_16072008.bin
11	09:27:40 17/07/2008	radhika.hs@Intemsys.com	Success	Group2_134436_16072008.bin
12	09:27:40 17/07/2008	radhika.hs@Intemsys.com	Success	Group1_134436_16072008.bin

Figure 9. 597: Email Status

#### 9.2.11.4.5. Device Information

The Device Information displays the following information about the device,

- Recorder name
- Description
- Duration for which recording has been done.
- Duration for which display is ON.
- CF Card Memory size in MB
- Channel information such as the number of onboard Analog Input channels, External Channels, Calculation channels, Onboard Digital Channels, Analog Output Channels and Relays.
- Languages supported by the recorder
- Features available, i.e. USB, Software Up gradation, Email and FTP
- Product details, i.e. Software Version, IP address and MAC Address of the device

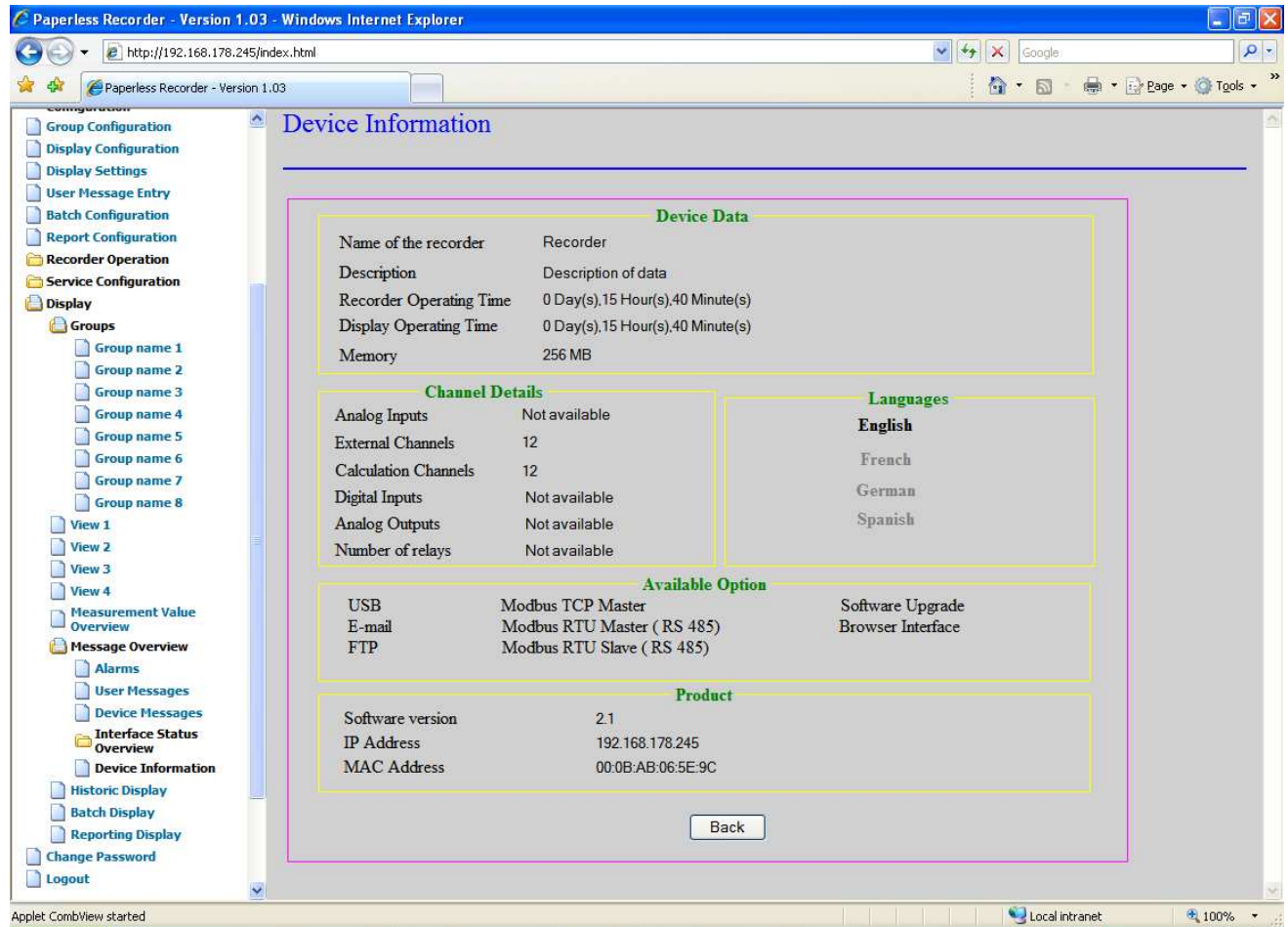

Figure 9. 608: Device Information

### 9.2.11.5. Historic Data

On Selecting “*Historic Data*” option from ‘*Display*’ menu, the corresponding screen will be displayed.

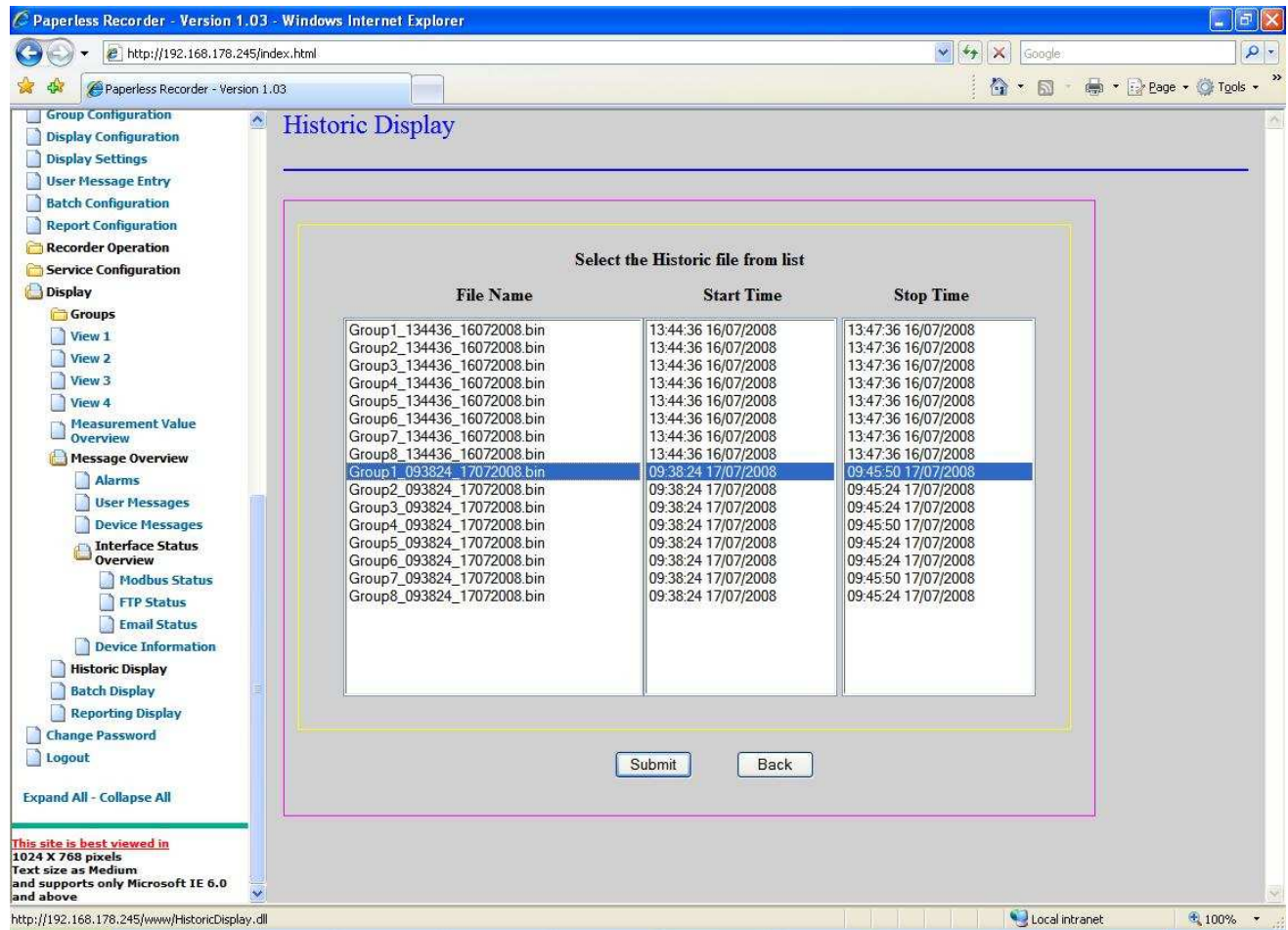

Figure 9. 619: Historic Data

This screen will display the list of group files, which reside in the recorder along with their start & stop time. Select a file from this list and press 'Submit' button. The screen shown below will be displayed. The screen will allow you to select a maximum of 12 channel values to view in the historic mode.

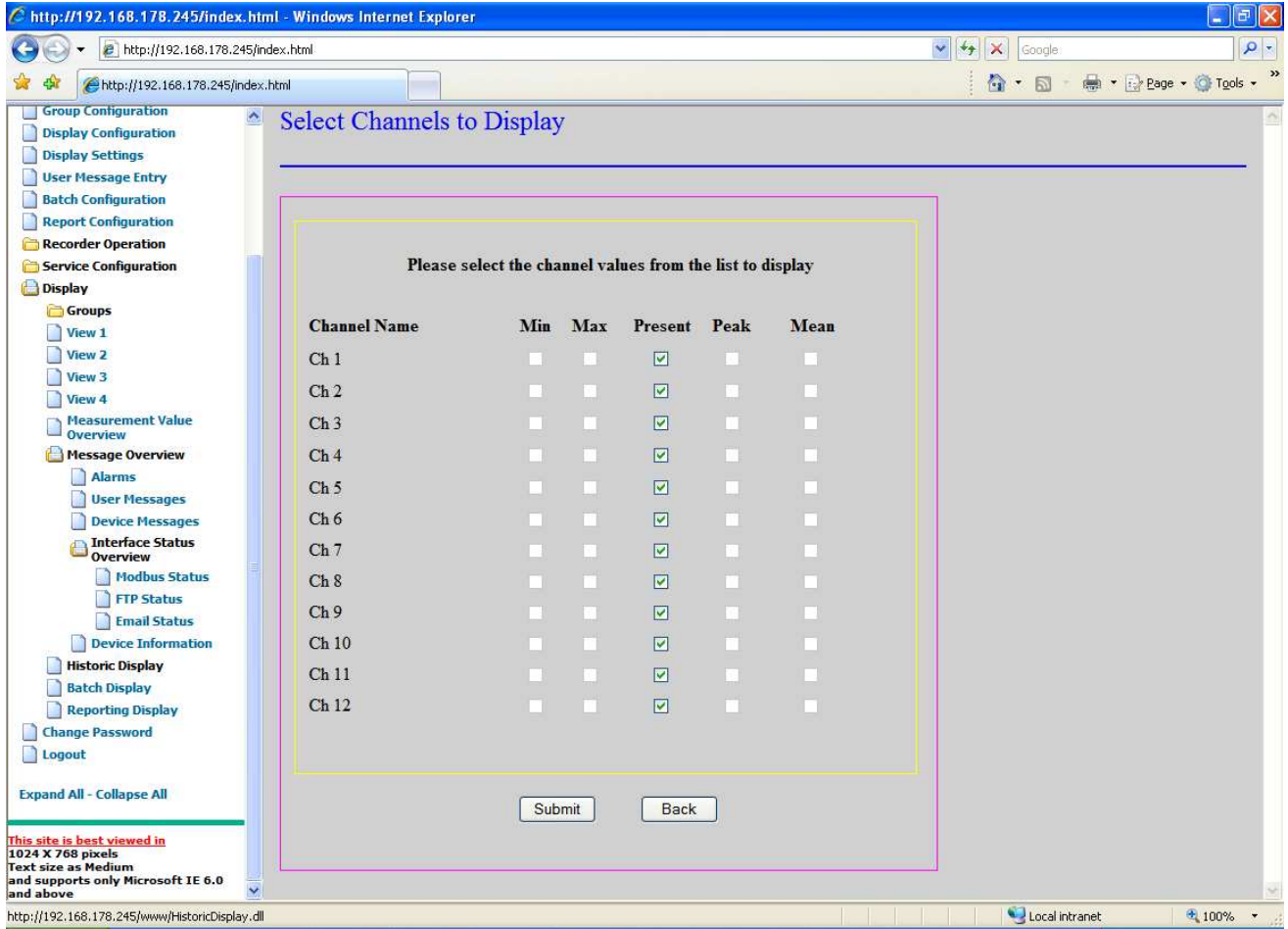

Figure 9. 80: Select Channels to display

After selecting 12 or less values from the available channels, press 'Submit' button to view the file in the historic mode (refer the below figure).

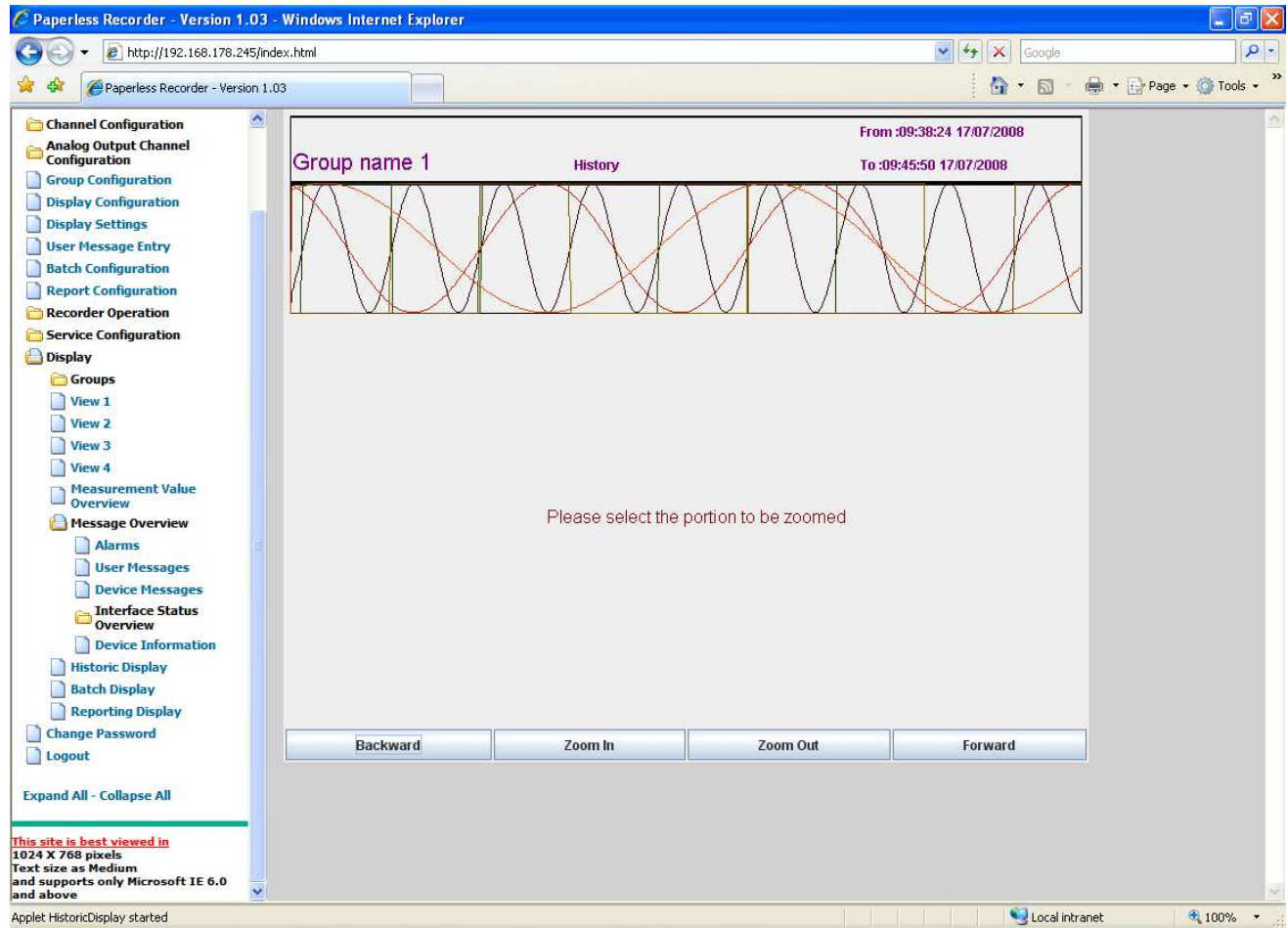

Figure 9. 81: Historic Data Overview

The display of the historic data is done in a two-section screen (upper part and lower part). The upper part will display the group's entire historic data (in horizontal display) along with group information such as group name and recording start and stop time, this is called the over view. The lower part of the display shows an enlarged view of the section selected by the user from the overview along with numeric value of the selected point in the enlarged historic view shall be displayed at the bottom of the graph area. The enlarged historic view is called Zoom view.

Before selecting a portion to view in the bottom section (zoom portion), a message "Please select the portion to be zoomed" will be displayed. To select a portion, press right button of the mouse on the overview section of the screen, drag the mouse to the right side and release the button to end the portion. Selected portion will be displayed in red color line (rectangular in shape), refer the below figure. The selected portion will be displayed in the zoom section of the screen along with a cursor and the numeric value based on the cursor position will be displayed in the numeric display boxes.



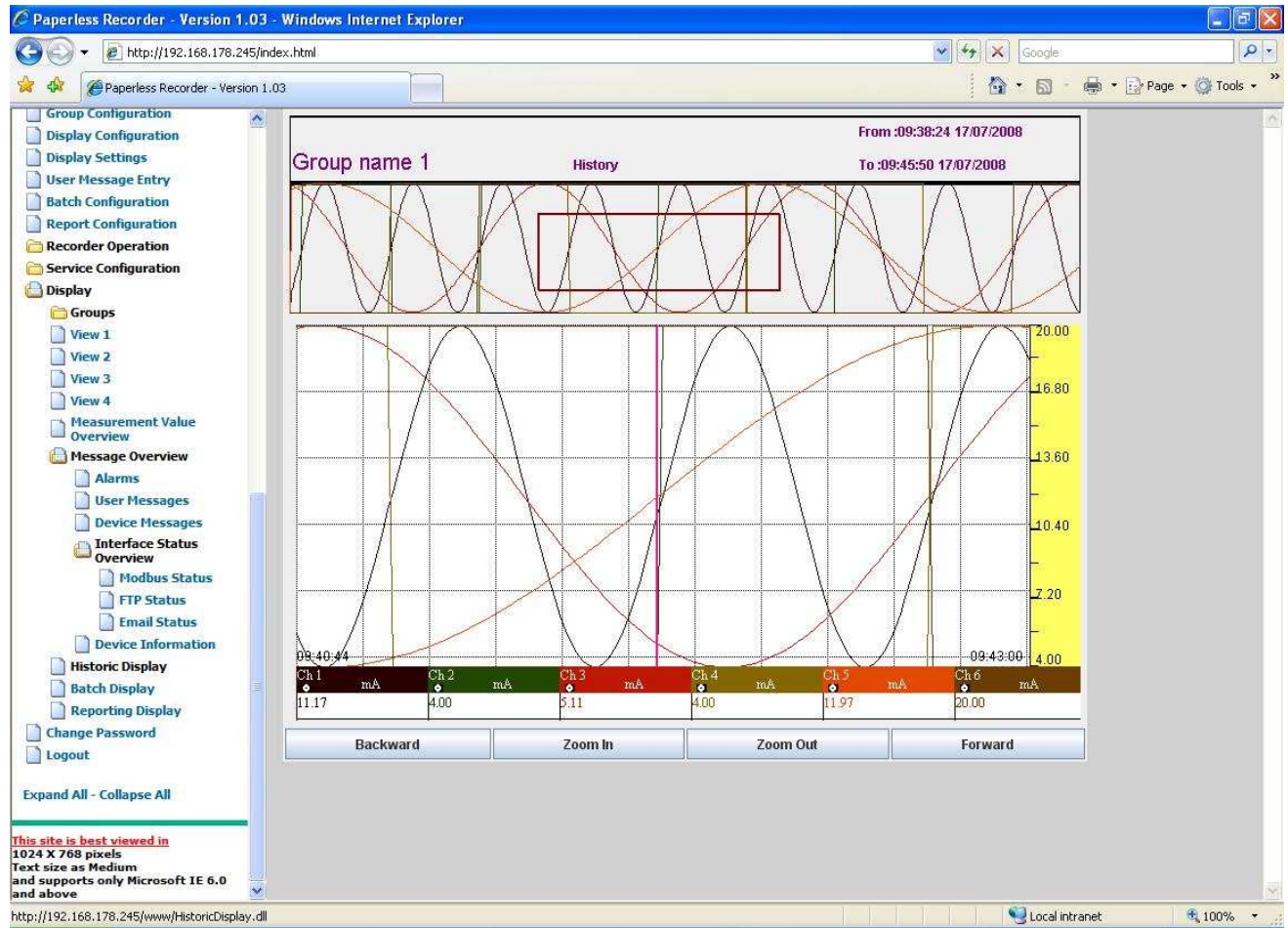

Figure 9. 622: Historic Data Display

The functionality of buttons available:

- Backward: Shifts the zoom cursor to the left of the screen.
- Forward: Shifts the zoom cursor to the right of the screen.
- Zoom In: Is used to expand the graphs, which are shown in the zoom portion of the screen.
- Zoom Out: Is used to compress the graph, which is shown in the zoom portion of the screen.

### 9.2.11.6. Batch Display

Batch is a group of channels (Maximum 44 channels can be there in a batch). Batch can be either live or historic. User can view any 12 channels from a batch at a time.

While live batch is being displayed in the browser, if any changes are made in Channel Configuration, Display Setting or temperature the live batch display will be reset. If Batch Configuration is changed then the display resets the display of the 12 channels, if the number of channels available for that batch is greater than 12 else it starts displaying with the available channels.

#### Live Batch:

Each batch, which is enabled in batch configuration, is considered as Live Batch irrespective of whether recording *ON* or *OFF*. Select 'Batch Display' from 'Display' menu, the below screen will be displayed. Click on live radio button, the list of batches available (maximum 4) will be displayed. Select any one of the batch and press submit button.

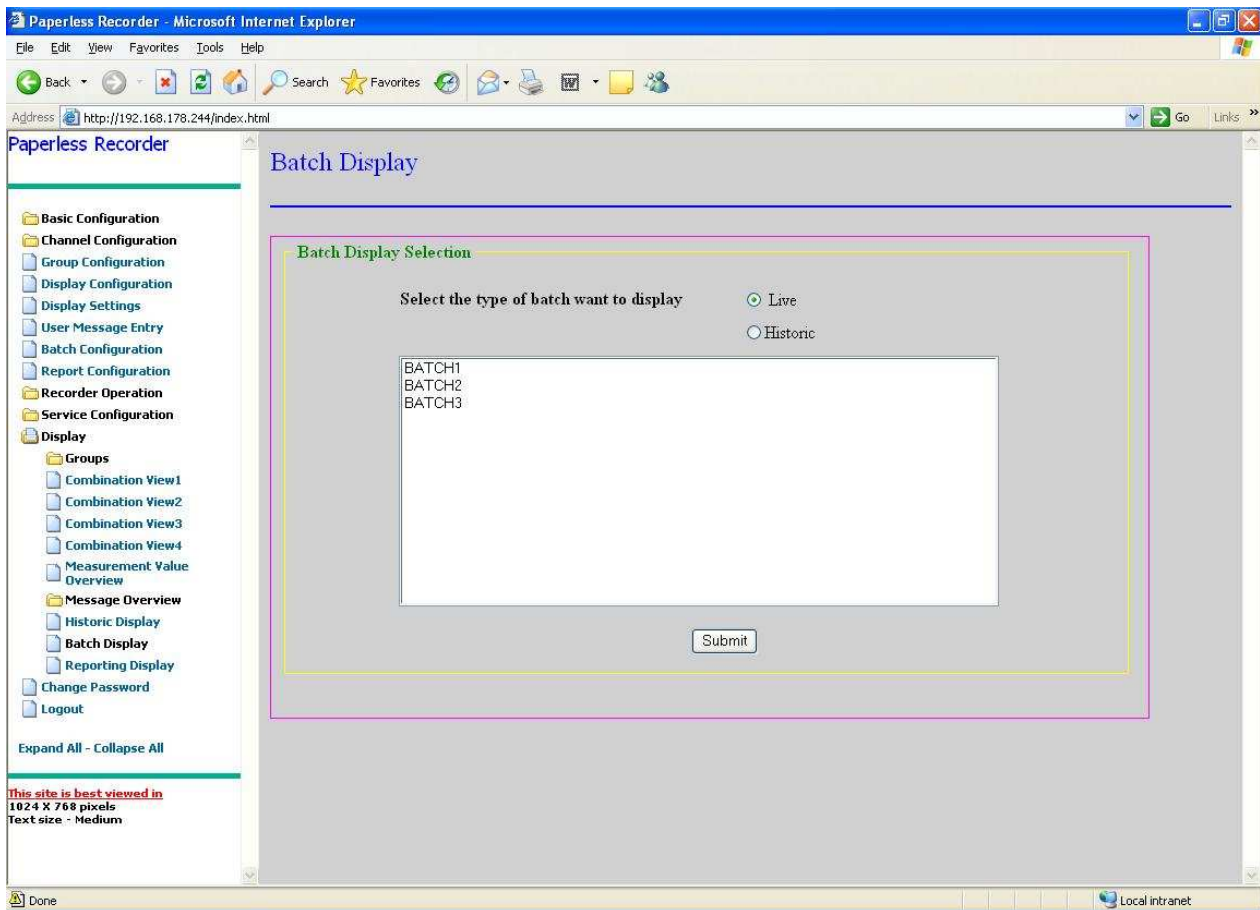

Figure 9. 8363: Batch Display

The list of channels which have been configured for the above batch will be displayed, refer the below figure. In live batch, a maximum of 12 channels can be viewed at a time.

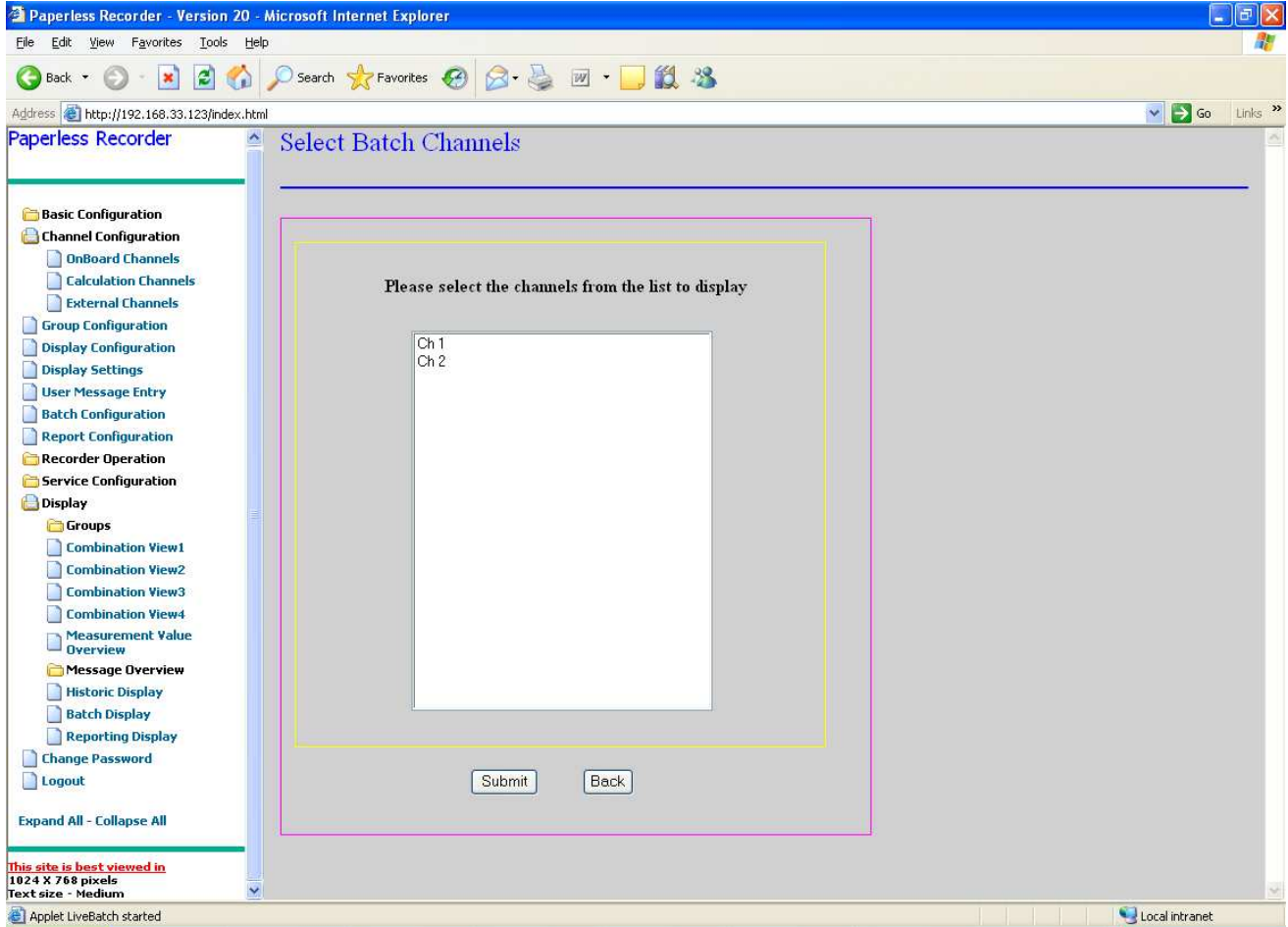

Figure 9. 644: Select Batch Channels

The channels selected, will be displayed with horizontal trend.

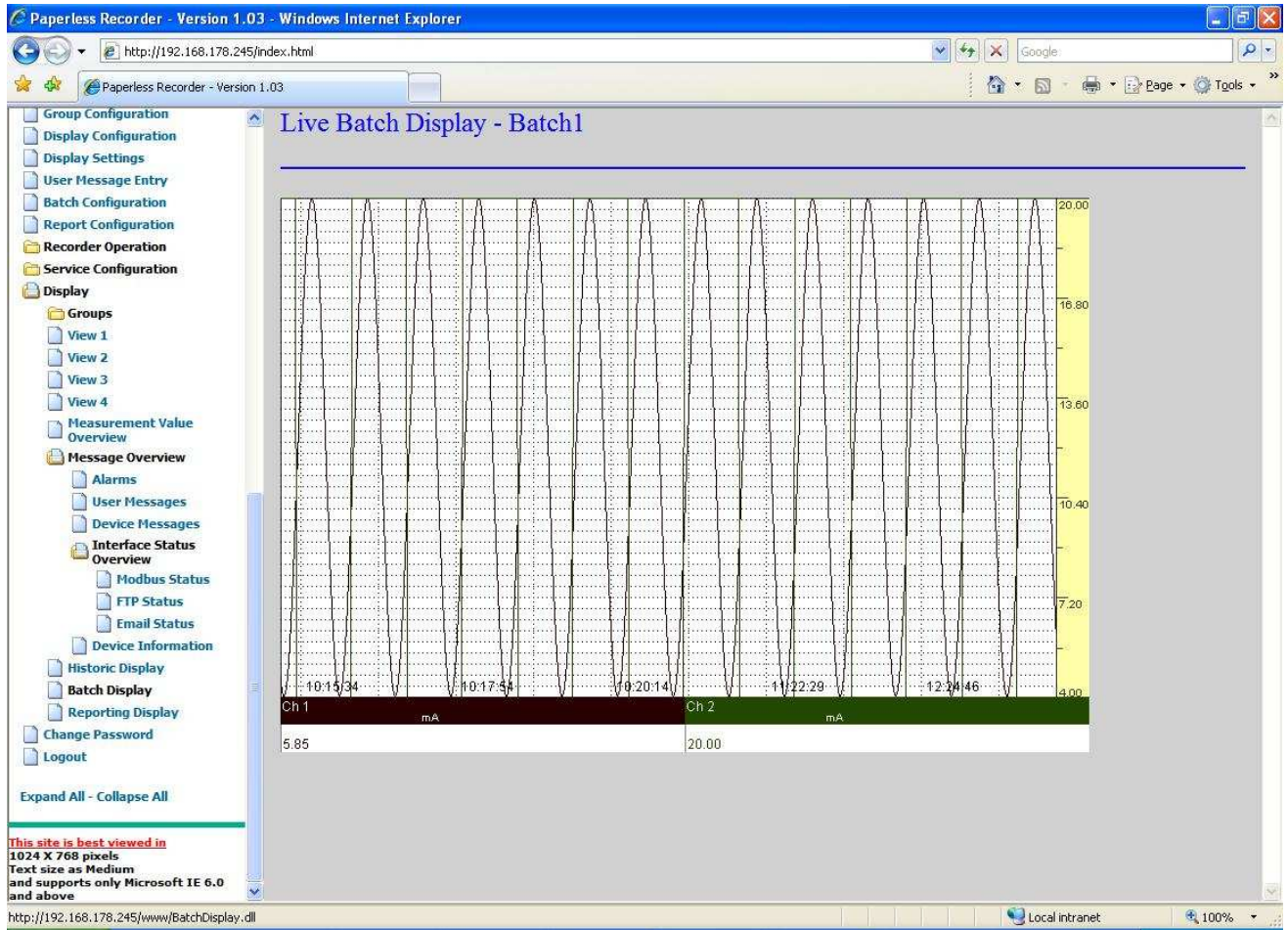

Figure 9. 85: Live Batch Display

### Historic Batch:

Select the '*Historic*' radio button. In historic batch only the present value (among min, max, present, mean & peak) of the channels can be viewed. The rest of the functionality is similar to that of historic data (please refer 9.2.11.6). Batch information, such as batch start & stop, batch description, batch number & batch duration will be displayed in the top portion of the window, as shown in the below figure.

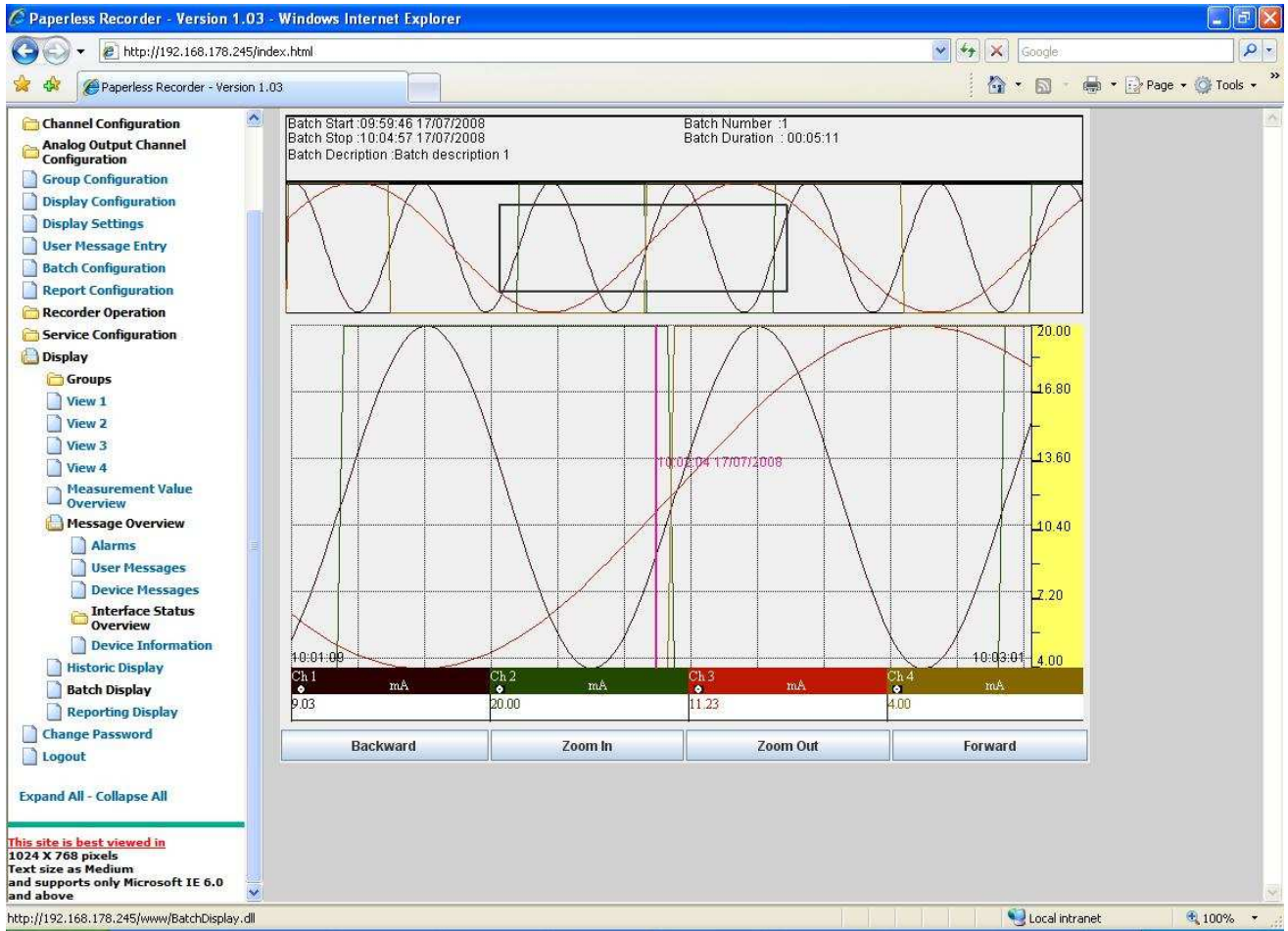

Figure 9. 656: Historic Batch Display

### 9.2.11.7. Reporting Display

By using this option you can view a channel's reports generated that residing in the recorder.

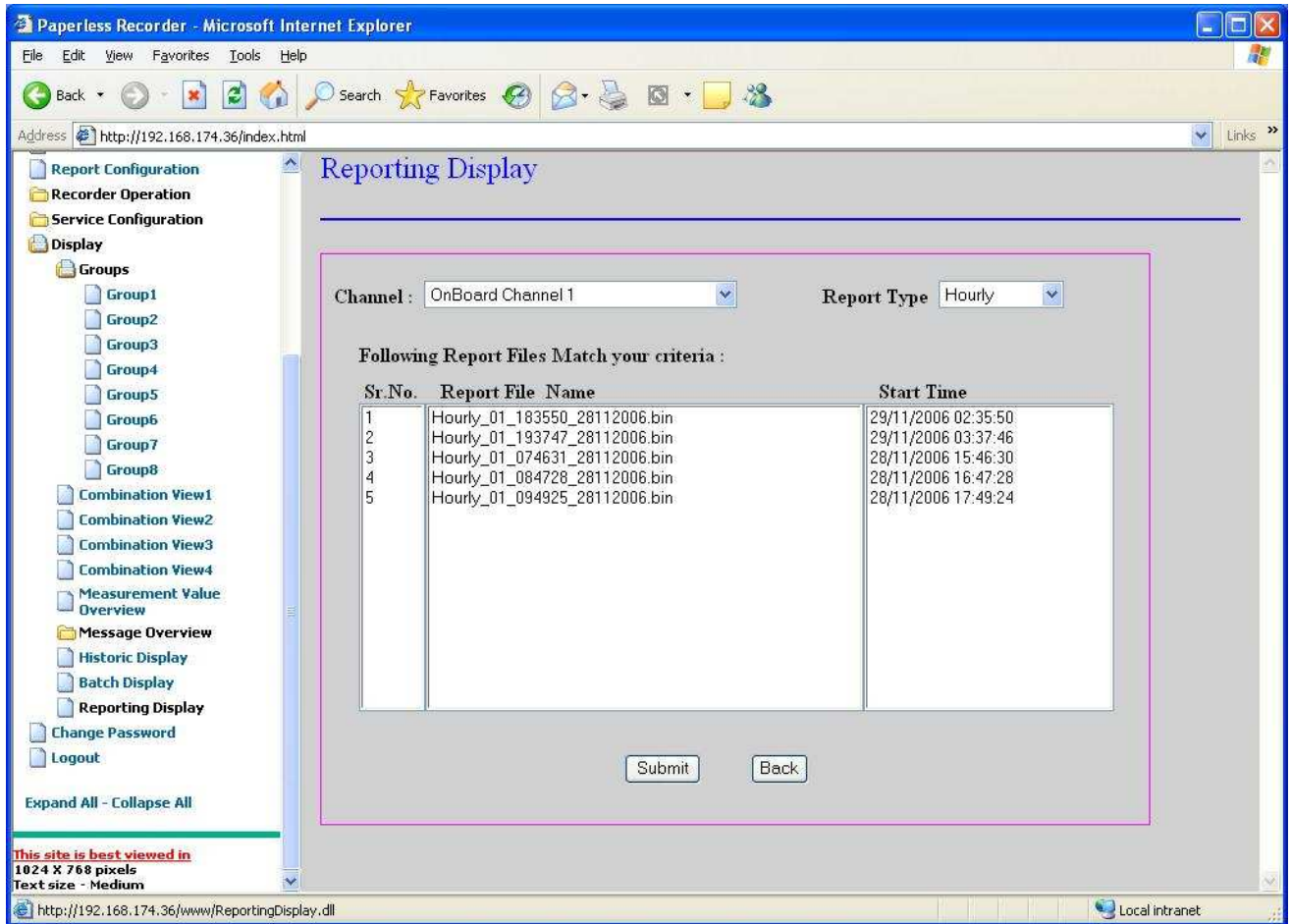

Figure 9. 667: Selection of Report to Display

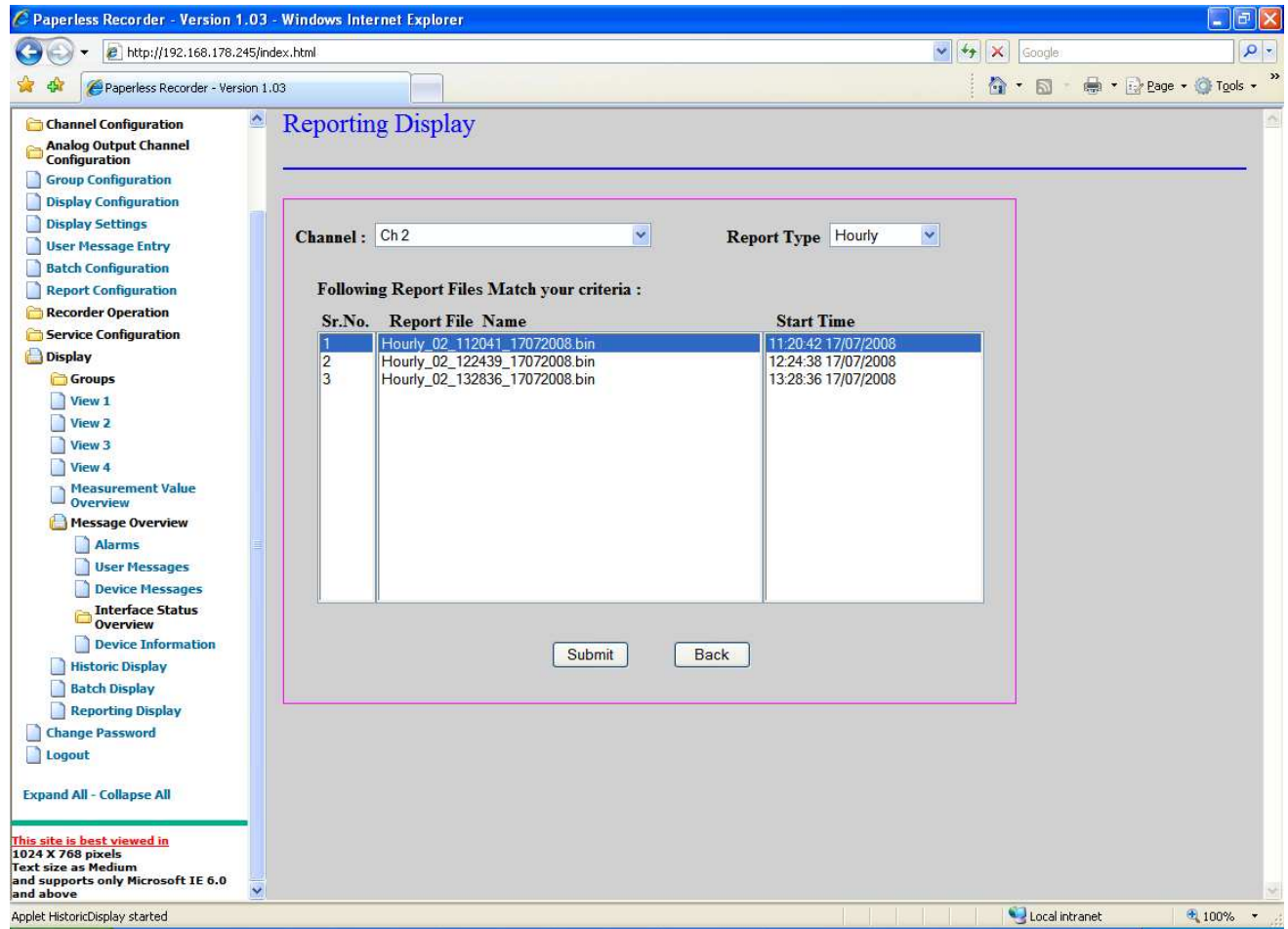

Figure 9. 678: Selection of Report to Display

1. Select a channel from the list of channels provided by the ‘*Channel*’ combo-box.
2. Select the Report Type from the following options:
  - Hourly report
  - Daily report
  - Monthly report
  - Annual report
3. After selecting the report type, you can see all the report files of the required type that reside in the memory, for the channel along with their starting date and time.
4. To see the contents of the report file, select the report’s file name from the list and click on the *Submit* button, this will show the report as shown in the figure below.
  - The channel name and all other channel related information (including report start and stop times) is shown in the upper part of the screen as a header.
  - Report contents shall be shown below this header.

Note: If any data type value such as: - Minimum, Maximum, Sum, Peak, Mean and Actual, is not selected while configuring the report, then in Standard Report it will display the value as “Not Available”.

The screenshot shows the 'Standard Report' page in a web browser. The left sidebar contains a navigation menu with categories like Channel Configuration, Analog Output Channel Configuration, and Display. The main content area displays the following report data:

Header Part			
Channel Name	Ch 2	Start Time	10:10:47 17/07/2008
Standard Recording Speed	1	Stop Time	11:20:41 17/07/2008
Event Recording Speed	1		
Report Type	Hourly		

Values		
	Value	Date & Time
Minimum	4.00	10:10:48 17/07/2008
Maximum	20.00	10:11:18 17/07/2008
Sum	24.00	
Peak	16.00	
Mean	12.00	
Actual	4.00	

At the bottom of the report area, there is a 'Back' button.

Figure 9. 689: Report Display

### 9.2.12. Change Password

By selecting this option the page below will be displayed.



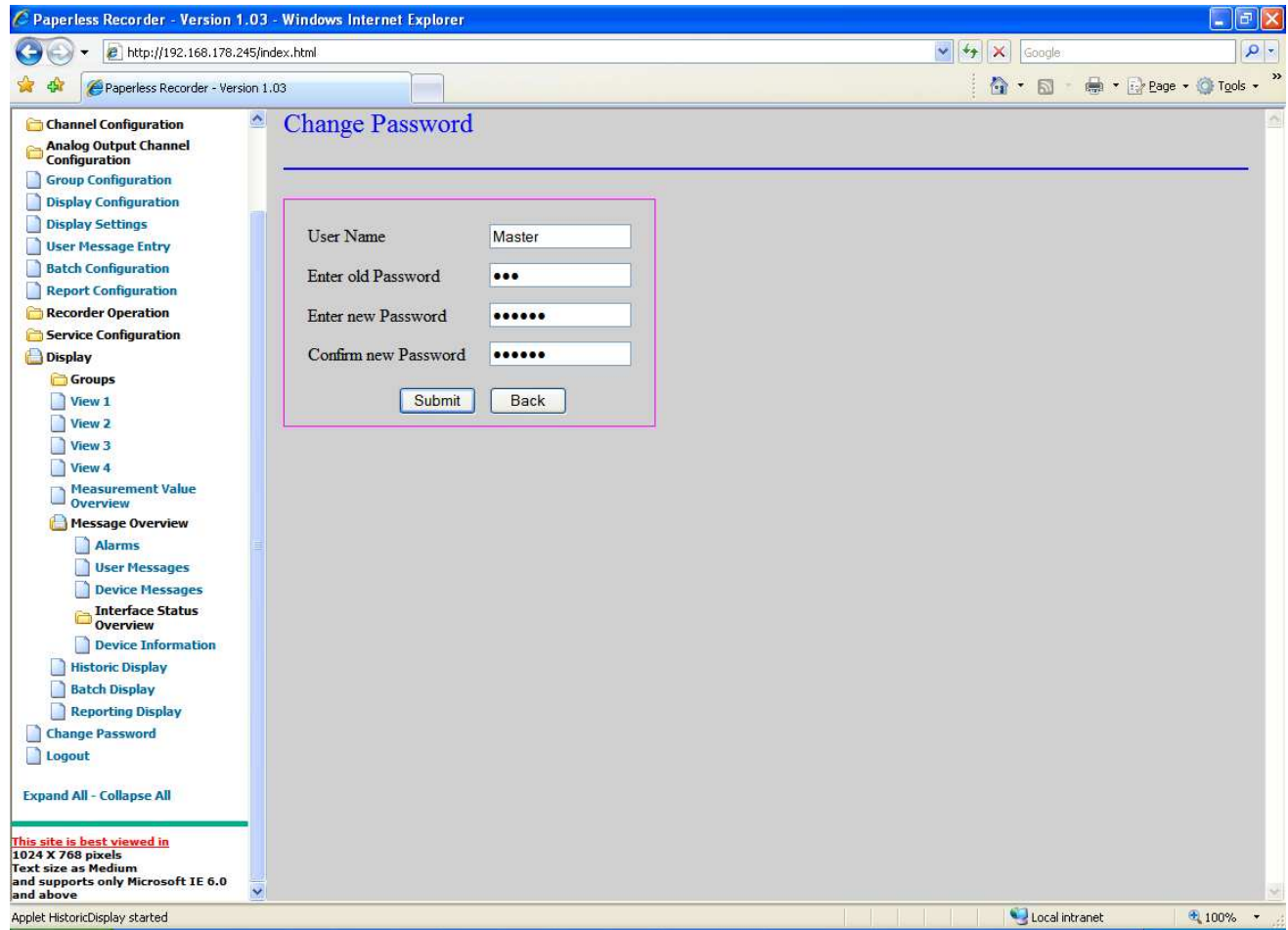

Figure 9. 90: Change Password

Here you can change your password. This is same as the change password option provided in the recorder. In the username field, the user name used by you to login will be displayed, you have to enter the current password as old password and enter a new password in both ‘Enter new Password’ and ‘Confirm new Password’ edit box. Click on *Submit* button to save the changes. After the password has been successfully changed the message “Password changed successfully” will be displayed.

### 9.2.13. Logout

This option is used to logout the currently logged in user and then login as some other user. Screen after ‘Logout’ will be as shown below. You refresh the page by pressing the “Refresh” button on status bar or by pressing “F5” the currently logged in user will be logged out and the start up image will be displayed at the right side of the page.

Note: Refreshing the page will logs out the logged in user.

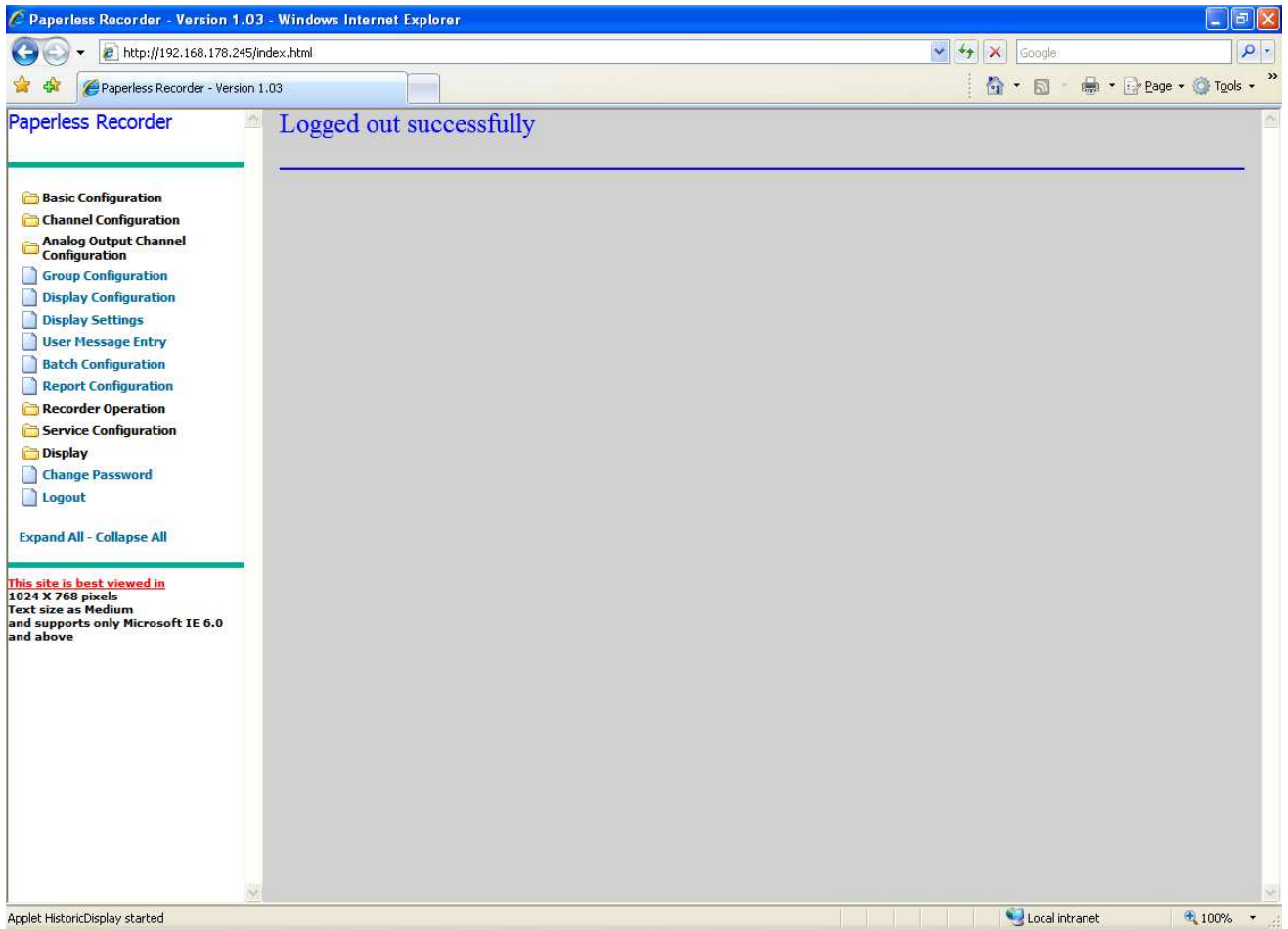

Figure 9. 91: Logout Screen

## 9.2.14. Miscellaneous Points

### 9.2.14.1 Server Time out

After login if you open any page and keeps the same page open for more than ten minutes without performing any operation, then the *Submit* button is clicked, the message “Server timeout, Please Reopen the page.” will be displayed. Then you have to reopen the page by clicking on the left side tree-structured menu. The time out for any page is 10 minutes.

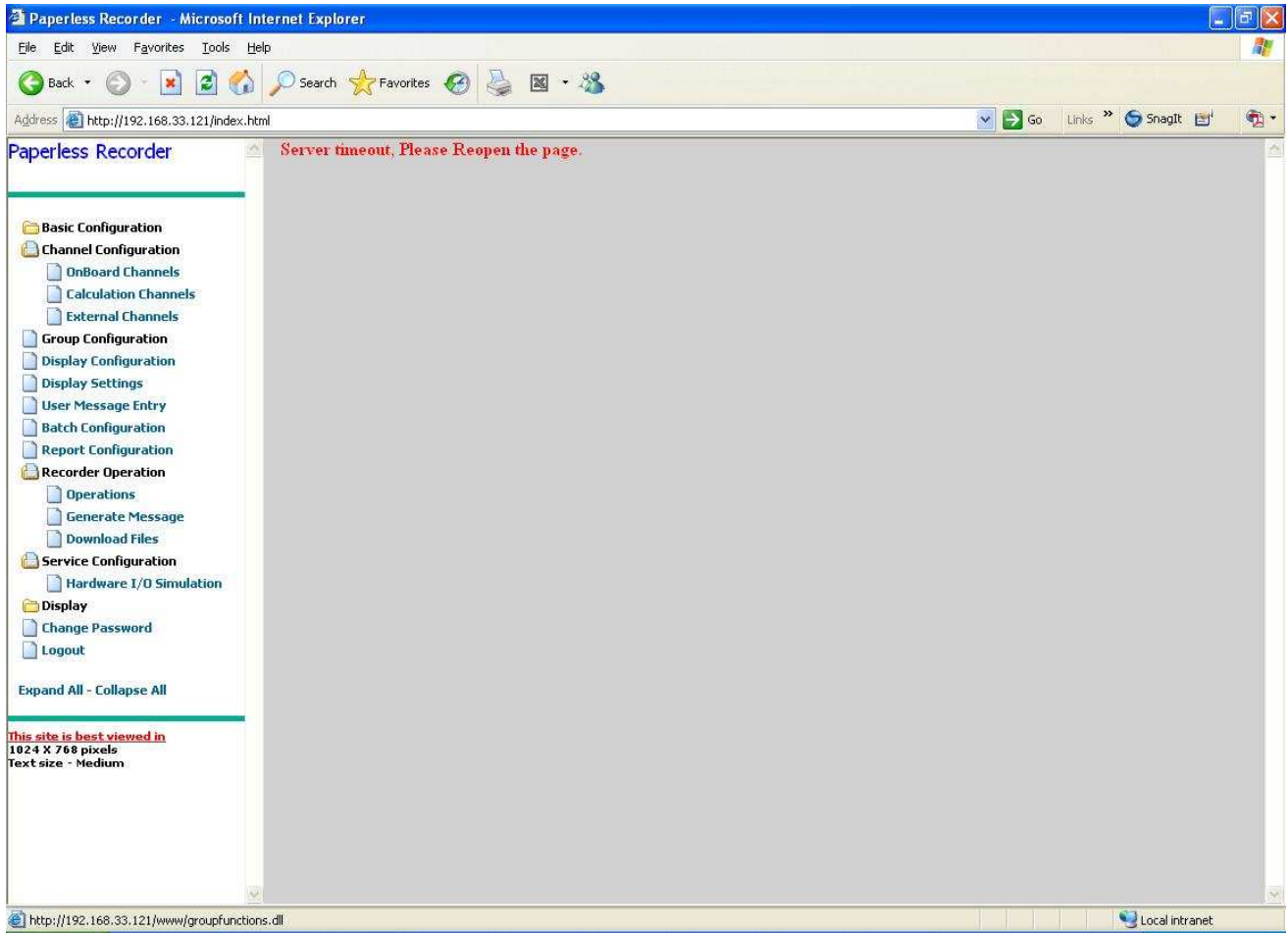

Figure 9. 92 Server Time Out

**Just keep a note of the below mentioned points which reflects a similar kind of problem:**

**Note:** The browser cache reflects the older Java class file implementations, if any minor changes are done, then it is recommended to check the implementation using multiple Ip address or different PCs.

Ex: The current Recorder IP address is 192.168.6.125, after making some modification, if changes are not reflected then user as to change the IP address like 192.168.6.123 and then check for the new modifications.

The problem arises due to the fact that the Browser cache gets referred under certain situations and instead of the reference being the latest Java class files.

**Possible Solutions:**

- 1) Empty your browser cache.  
Steps to delete the cache  
Go to Tools on Browser->Internet Options->Delete Cookies.  
If 1<sup>st</sup> one is not working then go with 2<sup>nd</sup> onwards, but we are preparing first one.
- 2) Change IP Address.

- 3) Change PC.
- 4) Format CF Card and then load with all the latest files .

Another issue to put in context is that on multiple refresh the Browser may sometimes show Wince Server busy message and the whole page becomes blank.

This is possibly due to the fact that on multiple refresh dlls gets loaded and unloaded again and again multiple times in quick succession because of this multiple new sessions are invoked and closed as a result of Overloading of the Server this message gets displayed.

#### **9.2.14.2 Navigator**

After Login if you select any of the configuration page to do some configuration and save the configuration by clicking on *Submit* button the navigator screen will turn gray in color as shown the figure below and you need to wait till the Navigator gets back to its original color for the further operations. And at the same time the progress bar at the bottom of the screen as shown in figure below will show you the percentage of process completed in green color and you need to wait till the process completes to save the configuration successfully .If on submitting, due to some connection error “Page Cannot be Displayed” screen is displayed then you need not to wait till navigator gets back to its original color and you can select any of the link to continue.

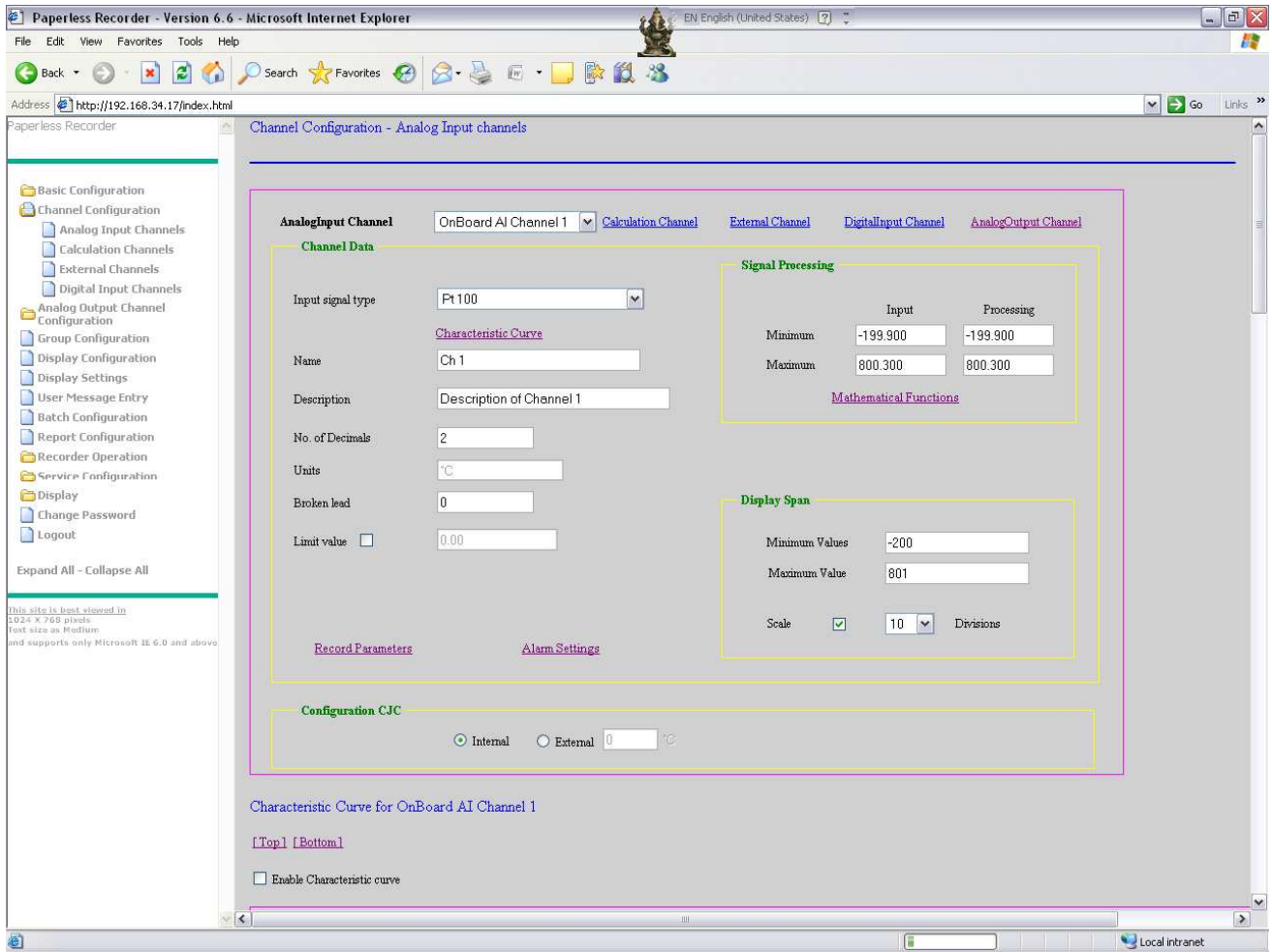

Figure 9. 93 Navigator

To open any of the pages in the browser a single click on the corresponding Navigator link is enough. If you try to open a page by double clicking on any of the link an alert message will be displayed as shown in the figure below.

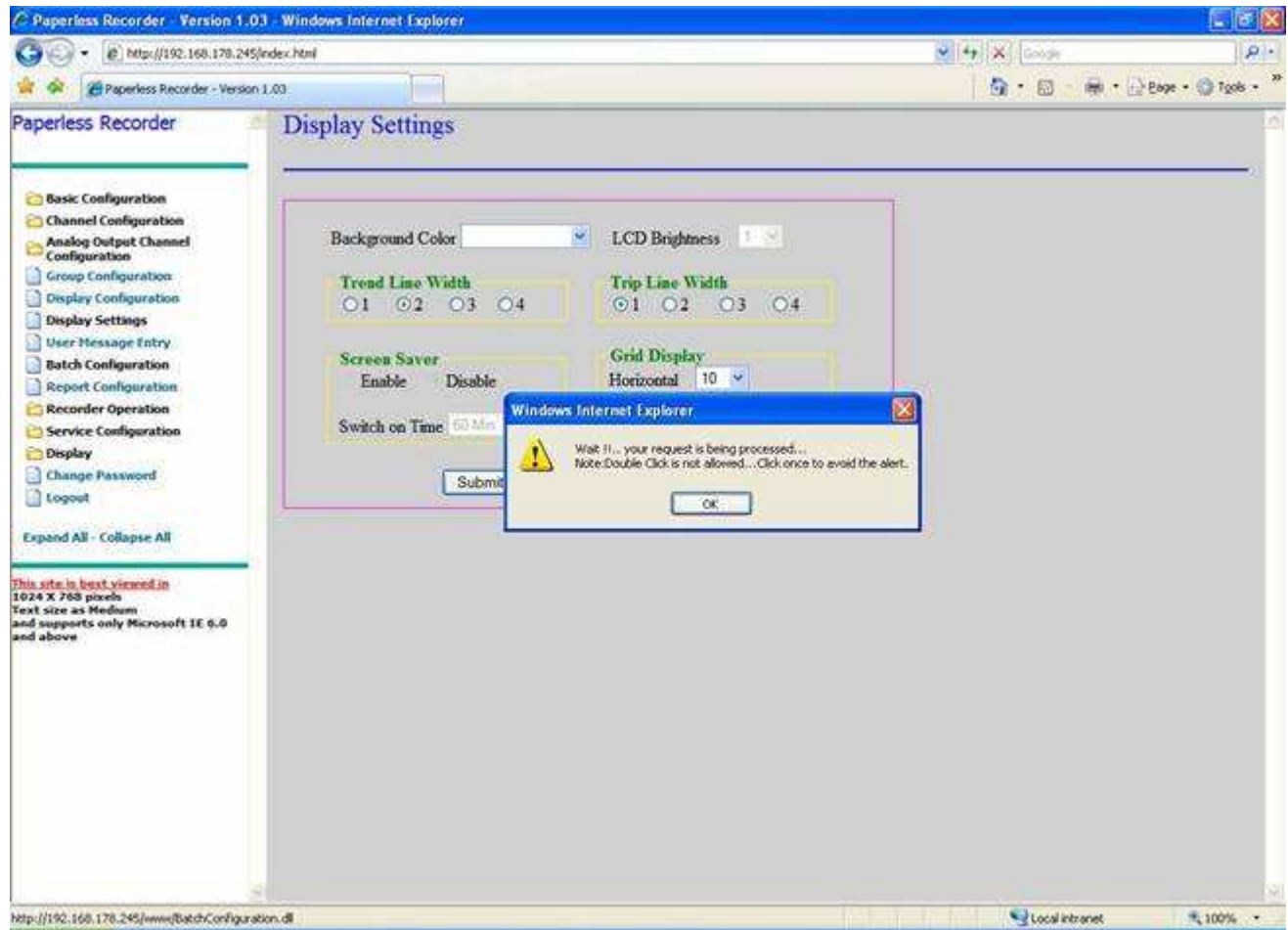

Figure 9. 94 Navigator

## 10 File Conversion tool

### 10.1 Introduction to File conversion tool

Conversion tool is a PC based application, which will convert .bin files that are generated from recorder to .csv, and .xml file formats. This tool always checks a folder (which can be configured) at a specified interval of time for new .bin files and converts to .CSV and/or to .xml file formats. It will be available in Release folder. Path specified as, Released Folder ->Tools->FileConversion

### 10.2 Using File conversion tool

Once after executing conversion tool application, new icon **CT** in the system tray will be displayed as shown in below figure.

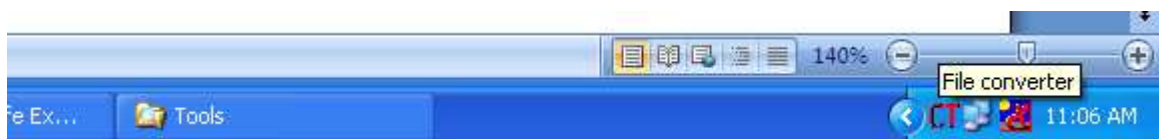

By this the execution of conversion application will starts, this application will check specified folder (by default current folder) at a specified interval (by default every 5 minutes) for new .bin files and converts to .CSV and .xml file formats and store in the same folder with same filename with .csv and .xml as extensions.

Double click on the **CT** icon to open “File Converter” dialog. This will be displayed as shown in below figure.



In the above dialog

### 10.2.1 Hide

By Selecting Hide button we can hide “File Converter” dialog (But still File conversion tool will be running)

### 10.2.2 Settings

By selecting settings button, a new dialog will be displayed as below

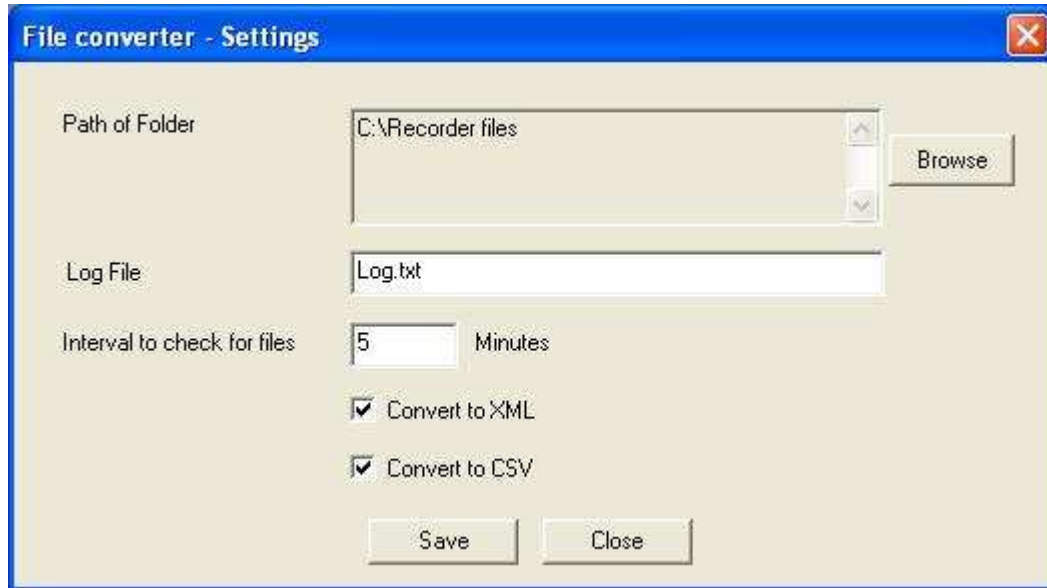

In this dialog

Path of folder: The folder where File conversion tool will check for new .bin will check.

Log File: This file will store each and every action of the application.

Interval to check for files: is the interval to check for new files.

Select Convert to XML check box to convert .bin to .XML file.

Select Convert to CSV check box to convert .bin to .CSV file.

### 10.2.3 View log

By selecting “View log” button of “File Converter” dialog, the log can be viewed in the notepad.

### 10.2.4 Convert now

By selecting this button, File converter tool will convert unconverted .bin files to .csv and/or .xml. And “Last checked at ....” Is the time at which conversion tool checked for unconverted .bin files.

Right click on the system tray icon to get the following menu

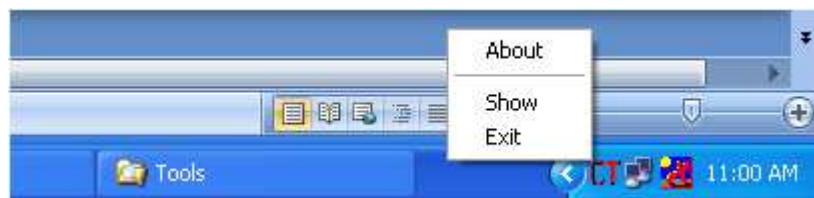

About option of above menu will display about dialog as shown in figure below



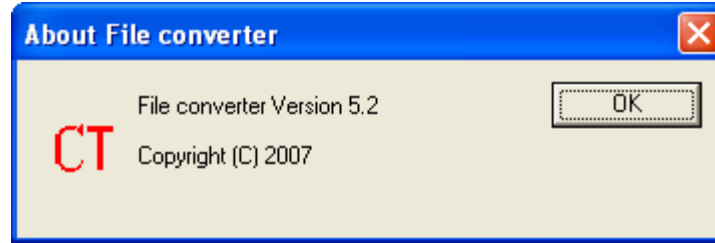

Show option of above menu will display “File converter” dialog.

Exit option of above menu will completely terminate the “File conversion tool” application.

## 11 Offline Configuration Tool

Offline Configuration tool is a PC based application used to generate a configuration file, which can be uploaded to Paperless recorder using USB. It will be available in the Release package in the Path specified as, Released package from LnT->Tools-> OfflineConfig.exe.

### Downloading OfflineConfig.exe from recorder to PC:

User can download the configuration tool from Recorder to PC in two ways.

1. Using memory stick
2. Using browser web Application.

To download Configuration tool from recorder, insert memory stick into USB port on front of a Recorder. Once the USB is inserted, it will be recognized by recorder and the menu ‘USB’ will be getting highlighted to user. Pressing menu item ‘USB’, following screen will appear.

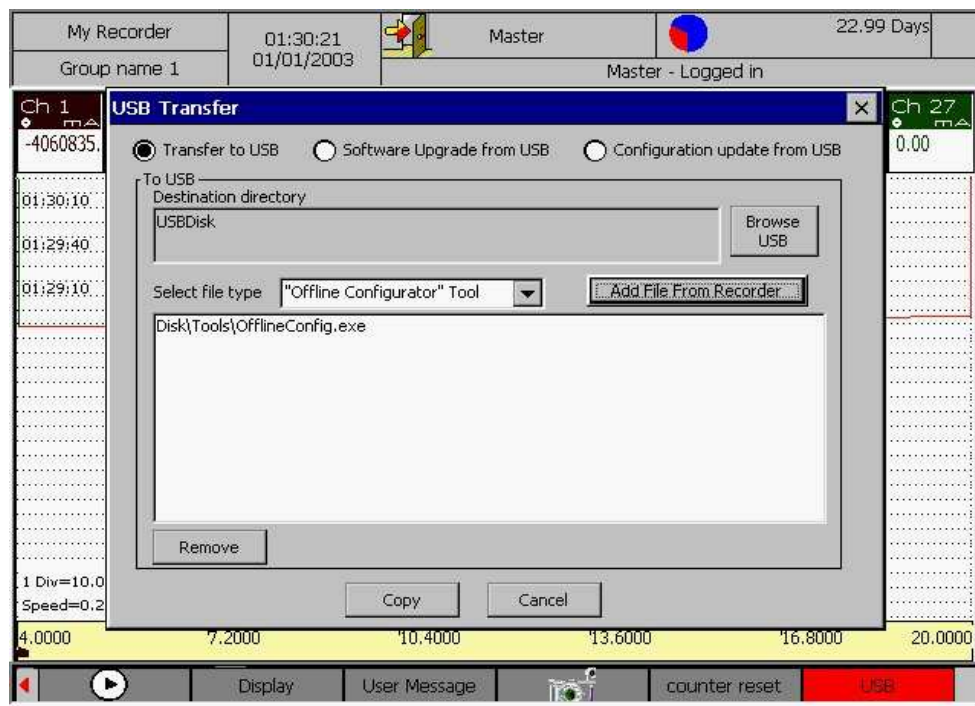

Select 'Transfer to USB' radio button and select 'Offline Configurator Tool' from 'Select file type' combo box. Desired file will be added and shown to the user after Clicking on 'Add File from Recorder' button as shown in the above figure. Pressing 'Copy' button will copy the added file into USB. Once the file is transferred to USB, a message popup "1 file(s) copied successfully" will be displayed. After downloading Configuration tool to memory stick, insert the stick into a PC and copy the Tool to the hard drive for further operations.

To download Configuration tool 'OfflineConfig.exe' from browser, go to menu 'Recorder Operations->Download Files'. Selecting type of file to be download as 'Software Tools' will display the list of Tools available in the recorder. User can save the file 'OfflineConfig.exe' to a specified path by right clicking on the file and selecting option 'save target as' as shown below.

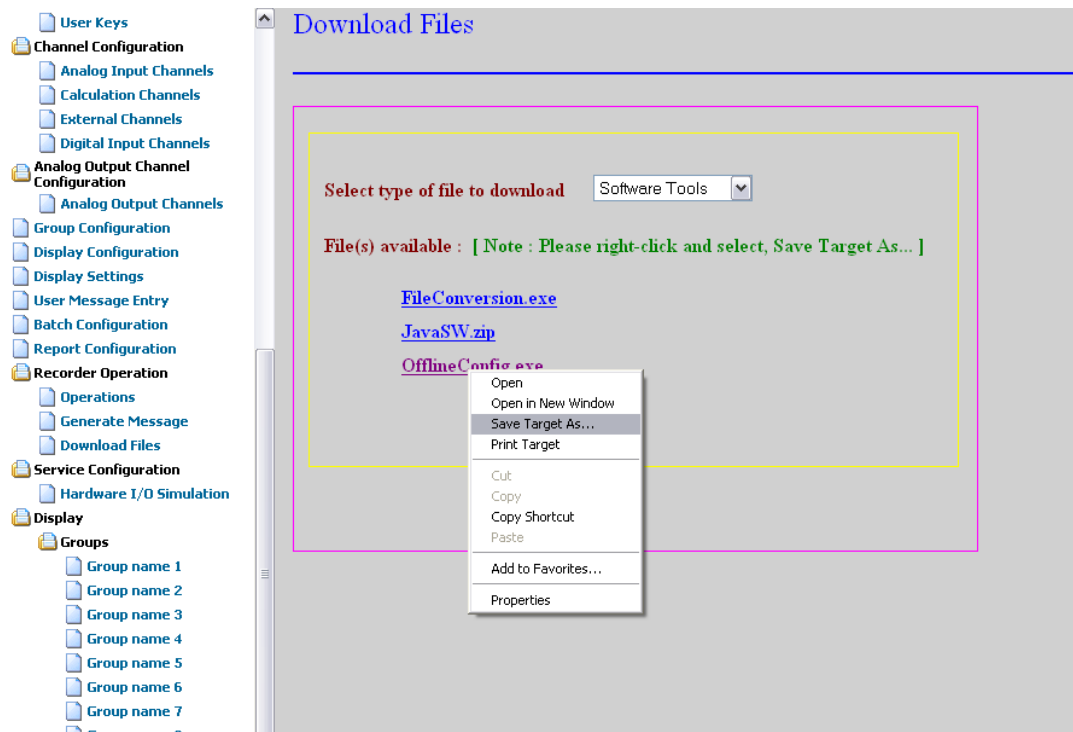

### Using Offline Configuration tool:

Double click on saved 'OfflineConfig.exe' file to launch the application. Main screen of the application will be displayed as shown below.

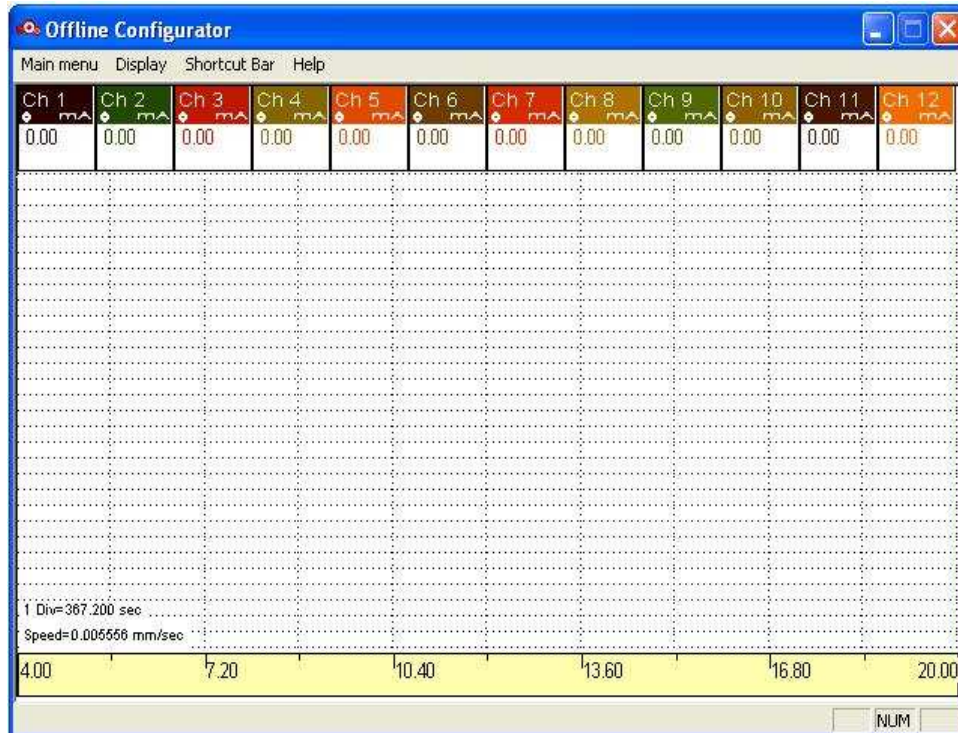

After executing 'OfflineConfig.exe' the file, a binary file named 'BasCof.dat' will be generated in the same path from where 'OfflineConfig.exe' is executed. Later any configuration change on the application will be saved into 'BasCof.dat'. User can update the Configuration file; currently running in the recorder with 'BasCof.dat' config file generated from Offline Configurator by using USB based memory stick.

Menu and operations on the applications are like recorder with the exception of "Save configuration as", "Open" and "Exit".

*Save Configuration as:* By choosing this option user can save the configuration to the local system (File name is user option).

*Open:* By choosing this option user can open and overwrite the Bascof.dat file. If user wants to open and load Paperless config file with other name also permitted to load into Offline Configurator tool.

*Exit:* By choosing this option user can terminate the application.

*Help:* This will give details about current application version.

*Not supported:* Language menu is not supported in the current version of the software but may be added in further product releases.

Note: Recording Start/Stop and Batch Start/Stop functionalities will not be available for offline configuration tool.

### Recorder Configuration file Update:

Copy the generated configuration file 'BasCof.dat' to USB. Insert USB into USB port on front of a Recorder. Once the USB is inserted, it will be recognized by recorder and the button 'USB' will be getting highlighted to user. Pressing 'USB' button, 'USB Transfer' dialog box will be opened. Select radio button

'Configuration Update from USB' and pressing 'Copy' button will open 'Select Configuration file' dialog and it shows the files available in USB. Select the configuration file which has saved in USB as shown below.

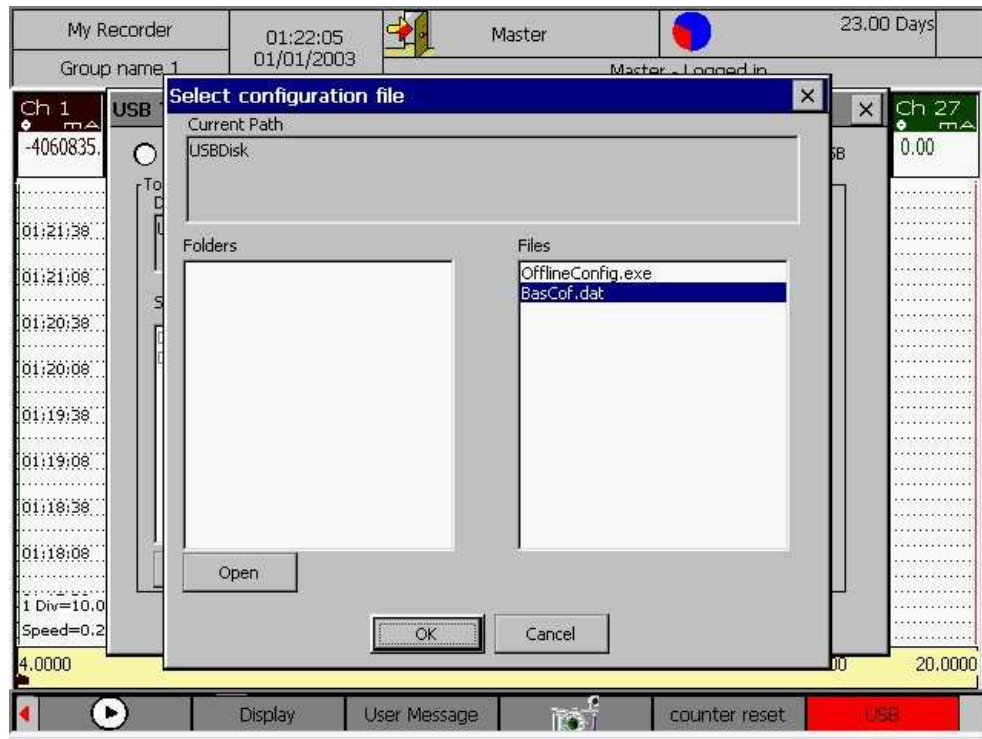

Pressing OK button will update the configuration file and popup a message "Successfully updated, Press OK to restart the recorder..." as shown below.

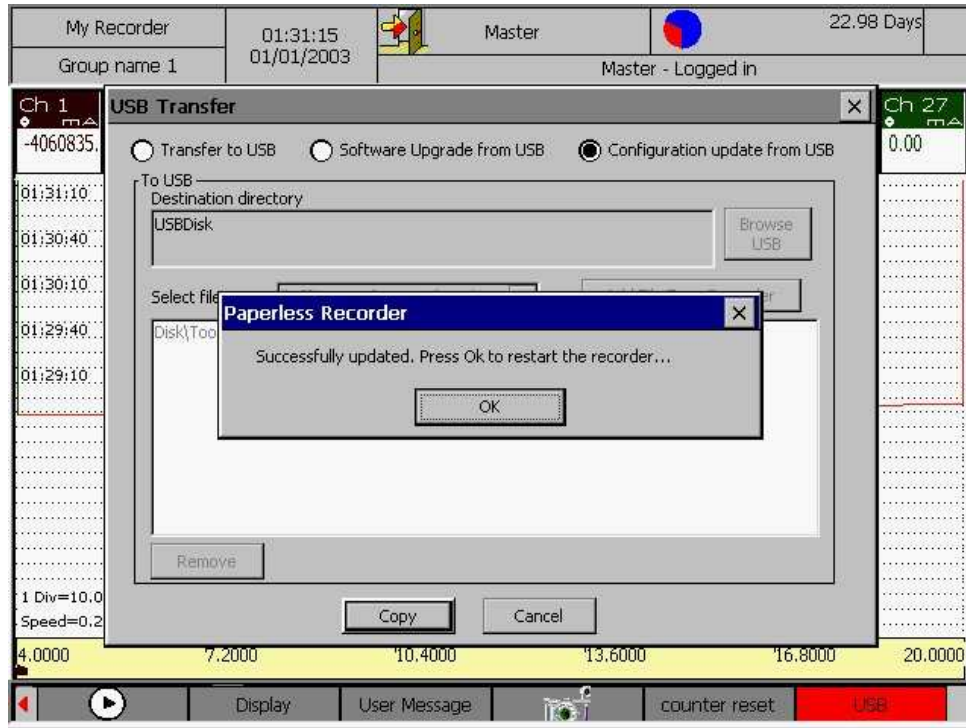

Pressing OK button on popup dialog will restart the recorder and recorder reopens the paperless application with the updated configuration file.

In case, if user tried to update configuration file with any corrupted/invalid file, recorder will pop up a message 'Selected config is not valid or corrupted'.

## 12 Appendix

### 12.1 APPENDIX A: RECORDER MODBUS/RTU SLAVE OPERATION

#### 12.1.1 Wiring Diagram/Pin Configuration of RS-485 Modbus connection

Connect a DB9 female cable to recorder as shown in figure 1, to establish a Modbus connection between Master and slave devices.

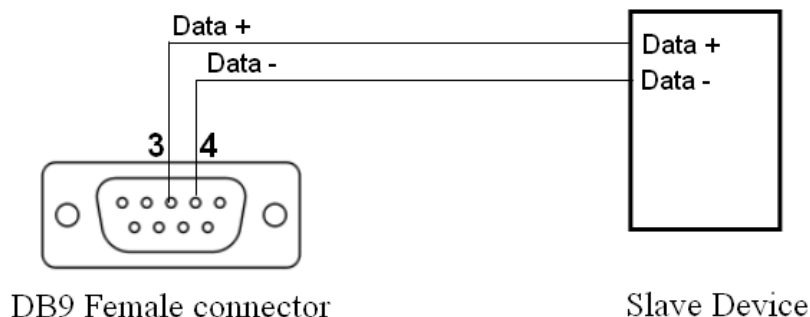

Figure 12.1.1

Data+ (A) and Data-(B) line are the lines used for ModBus 2-wire 485 connection.

#### 12.1.2 Modbus Address map Table

Parameter Name	Type	Address [ Instance No:]		Size in words
		Higher Byte (Category)	Lower Byte ( Number )	
<b>Channel Number 1-44</b>				
Process Value (PV)	WORD	1 to 44	0	1
Status Word 1	WORD	1 to 44	1	1
Input Type	WORD	1 to 44	2	1
Scale Range Min.	WORD	1 to 44	3	1
Scale Range Max.	WORD	1 to 44	4	1
Offset Value	WORD	1 to 44	5	1
Reserved/Unused				4
<b>Recorder Parameters - 45</b>				
Recorder IP address	String(16 TChar)	45	0	16
Recorder Operating Time	unsigned long	45	16	2
Recorder Display Operating Time	unsigned long	45	18	2
S/W Version Number	String(10 TChar)	45	20	10
No. of On-Board Channels	WORD	45	30	1

No. of External Channels	WORD	45	31	1
No. of calculation channels	WORD	45	32	1
No. of Relays	WORD	45	33	1
Batch ID Via Modbus - 46				
Batch ID	WORD	46	0	1

Table 12.1.2

For example; Calculating Signal Address (Instance No :) for accessing process value of digital channel 1 (Channel 37) in slave recorder.

## Address Format

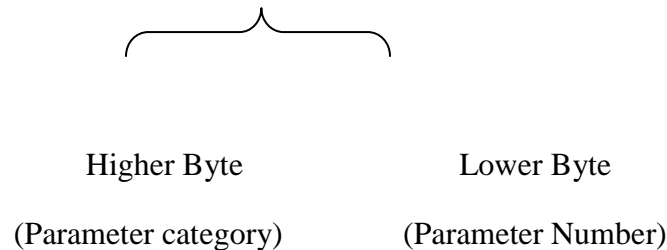

In this example parameter category is 37 (channel 37) and parameter Number is 0 (from table, corresponding number for process value is 0). Convert higher byte and Lower byte values to hexadecimal. (i.e.) hexadecimal for 37 is 25 and Hexadecimal for 0 is 00. Combine these values, 25 00. Convert this value to decimal (9472) and enter as Signal Address [Instance No].

The status of Modbus can be verified from Modbus log messages (Display >message overview > Interface status overview > Modbus status). Third column in Modbus status shows Status of the corresponding slave address and parameter address, i.e. Success if communication with the corresponding slave is successful and Failed if communications with the corresponding slave has failed

**Important Note:**

- Ensure that the master and slave have same communication parameters settings such as Baud rate, Data length, Stop bits and Parity.
- Termination of RS 485 channel should be taken care while connecting a master device to multiple slave devices.
- Recorder parameters of a slave recorder cannot be scanned in a master recorder.
- Recorder as a slave device can share this parameter values by using HMI application that runs on a Personal Computer. By using RS232 to RS485 converter you can establish a connection between slave recorder and HMI application.

