

Quick Start Guide

HMC7-MO-1

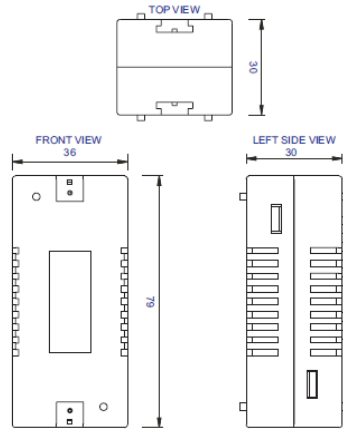

Dimensional Details:



Description:

HMC7-MO-1 I/O expansion module with 12 digital relay outputs.

Contents:

- 1 HMC7-MO-1 (in plastic bag)
- Quick Start Guide

Programming software (MAPware-7000), cables, and power supply purchased separately.

Specifications:

Power:	3.9VDC from HMC7000 base
Digital Outputs:	12 relay type outputs
Turn ON time:	10 msec
Turn OFF time:	5 msec
Output Capacity:	2A per contact
Auxiliary Power Supply:	
Input Voltage:	24VDC
Input Current:	150mA
Connection Method:	Removable terminals (3.81 mm pitch)
Operating Temp:	0 to 55° C
Humidity:	10% to 90% (non-condensing)
Dimensions:	3.11 x 1.18 x 1.42 inches [79x30x36mm]

Mounting Module to HMC7000:

The HMC7 I/O module must be mounted onto the back of a HMC7000 Series unit using one of the HMC expansion ports. When locating equipment behind the HMC7000 ensure that AC power wiring, PLC output modules, contactors, starters, relay and any other source of electrical interference are located away from the HMC7000. Make sure that variable speed drives and switching power supplies are located away from the unit.

Step 1 Step 2 Step 3

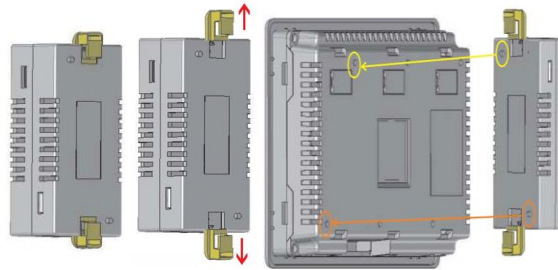

Step 1: Pull the two white lock connectors out from the center of the module.

Step 2: Place the module onto the HMC7000 expansion port so that the I/O module interconnect plug can attach to the HMC7000 socket. *Note: remove the protective tab on the HMC7000 expansion port to expose the socket.*

Step 3: Push down the lock connectors to safely secure the I/O Expansion module.

Wiring I/O Expansion Modules:

The HMC7 I/O module has green block terminals that are used to wire the module to the digital input devices (i.e. switches, contacts, etc). The block terminals can be physically removed from the module to facilitate connection (18 gauge wire recommended). *Note: A 3/32" flat blade screwdriver should be used to tighten the screws of the terminal block.*

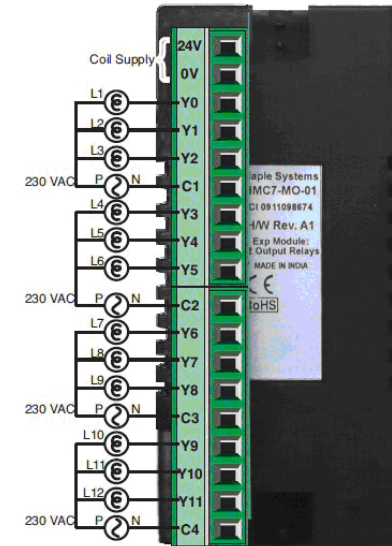

*L1 to L12 are A.C. Load.

Configuration:

Use MAPware-7000 to assign output (Y and YW), and configuration (MW) memory addresses to the module. These addresses are created according to the slot location of the module, where **nn** refers to the slot number:

Register	Description	Access
Ynn000- Ynn011	Output Bits	Read/Write
YWnn00	Output Word Data	Read/Write
MWnn00	Relay Output	Read/Write

PC Requirements for MAPware-7000:

Processor: 1 GHz Pentium-based processor or equivalent
 Operating System: Microsoft Windows XP Professional, 2000, Vista or Windows 7
 RAM: 1 GB
 Hard Disk: 800 MB (including 200MB for the .NET Framework Redistributable)
 Display: 1024x768 high color 16-bit
 Mouse/Keyboard: Required
 USB port: for project downloads

Installing the Software:

1. Insert MAPware-7000 CD into CD-ROM drive and follow instructions.
2. If software installation does not automatically start, click \SETUP.EXE from CD directory.

Additional Resources:

Detailed instructions on the operation and installation of the HMC7000 Series are available in the HMC7000 Programming Manual that is included with the MAPware-7000 configuration software. MAPware-7000 also includes help files which provide detailed information on using the configuration software.

Other Sources (visit Maple Systems Support Center website):

- Controller Information Sheets - specific information on connecting a particular manufacturer's PLC to the HMC7000
- Cable Drawings- wiring diagrams to particular PLCs
- Technical Notes- Provides additional information and examples not covered in the operations manual
- Software Upgrades- Upgrades to the MAPware-7000 software

 **WARNING: DO NOT REMOVE OR REPLACE WHILE CIRCUIT IS LIVE UNLESS THE AREA IS KNOWN TO BE FREE OF IGNITIBLE CONCENTRATIONS OF FLAMMABLE SUBSTANCES.** This equipment is suitable for use in Class I, Division 2, Groups A, B, C and D or non-hazardous locations only.

 **WARNING – EXPLOSION HAZARD –** Do not disconnect equipment unless power has been removed or the area is known to be non-hazardous.

 **WARNING – EXPLOSION HAZARD -** Substitution of components may impair suitability for Class I, Division 2.

It is recommended that the user periodically inspect the sealed devices used and check for any degradation of properties and replace as necessary.

For Technical Support:

Please contact Maple Systems if you have any questions regarding this product. We ask that you provide us with the unit serial number and firmware revision number written on the product label of the unit.

Maple Systems Inc.
 808 134th St. SW, STE 120
 Everett, WA 98204
 Tel: 425-745-3229
 Fax: 425-745-3429
 Email: support@maplesystems.com
 Website: www.maplesystems.com