

HMC7000 Series

Installation Guide

Introduction

Thank you for purchasing a Maple Systems HMC7000. The HMC7000 Series are HMCs (Human Machine Controllers) configured using the MAPware-7000 software ([purchased separately](#)).

This booklet describes the steps necessary for installing the HMC7000 Series.

For information on programming and configuring the HMC, please refer to the **HMC7000 Series Programming Manual** included with the MAPware-7000 software or available for download. For additional information, please refer to the Support Center section on our website, www.maplesystems.com. The Support Center provides links to manuals, FAQs, technical notes, training videos, sample projects, controller information sheets, and controller cables.

Static Awareness

Do NOT remove the rear cover of your HMC7000 Series product – doing so will void your warranty. When the rear cover is removed the circuitry inside is exposed to possible damage by electrostatic discharge during handling. Minimize the possibility of electrostatic discharge by:

- Discharging personal static by grounding yourself prior to handling the HMC.
- Handling the HMC at a static-free grounded workstation.
- Connecting the frame ground (\perp) connector of the HMC to a clean earth ground.
- Placing the HMC in an antistatic bag during transport.

Unpacking the Unit

Carefully unpack the HMC. Please read any instructions or cautions that appear on the shipping container. Check all material in the container against the packing list. Maple Systems, Inc. will not accept responsibility for shortages against the packing list unless notified within 30 days. The equipment and accessories were inspected and tested by Maple Systems before shipment; all of the equipment should be in good working order. Examine the equipment carefully; if any shipping damage is evident, notify the carrier immediately. You are responsible for claim negotiations with the carrier. Save the shipping container and packing material in case the equipment needs to be stored, returned to Maple Systems, or transported for any reason.

Packing List
HMC7000 Series
Power Connector
Mounting Clamps
HMC7000 Series Installation Guide

Warranty

Maple Systems warrants each HMC7000 product (not including I/O expansion modules) to be free from electrical and mechanical defects in materials and workmanship for a period of one year from the date of shipment. Maple Systems warrants each HMC7000 I/O expansion module product to be free from electrical and mechanical defects in materials and workmanship for a period of ninety days from the date of shipment. This warranty does not apply to defects in the Products caused by abuse, misuse, accident, casualty, alteration, negligence, repair not authorized by Maple Systems, use on current or voltages other than specified by Maple Systems, or application or installation not in accordance with published instruction manuals. This warranty is in lieu of any other warranty either expressed or implied.

Maple Systems liability is limited to the repair or replacement of the Product only, and not costs of installation, removal, or damage to user's property or other liabilities. If Maple Systems is unable to repair or replace a nonconforming Product, it may offer a refund of the amount paid to Maple Systems for such Product in full satisfaction of its warranty obligation. Maximum liability of Maple Systems is the cost of the Product.

Information furnished by Maple Systems, Inc., is believed to be accurate and reliable. However, no responsibility is assumed by Maple Systems for the use of this information or for any infringements of patents or other rights of third parties which may result from its use. No license is granted by implication, or otherwise, under any patent or patent rights of Maple Systems, Inc. Maple Systems retains the right to revise or change its products and documentation at any time without notice.

HMC7000 Models

What is a HMC7000 Series?





The HMC7000 Series are combination HMI (human machine interface) and PLC (programmable logic controller) in one unit. The HMC7000 can be used as a stand-alone unit capable of connecting directly to inputs and outputs (both digital and analog sources) through the use of optional expansion I/O modules. These I/O modules are controlled using industry standard ladder logic instructions built-in to the programming software. The HMC (human machine controller) also has a display and keypad/touchscreen to allow a plant floor operator visual feedback as well as direct input to the industrial automation system.

In addition, the HMC7000 can connect to external PLCs or other controllers via a serial connection. This flexibility provides access to most major manufacturer PLCs such as Rockwell Automation (Allen Bradley), Schneider Electric (Modicon Modbus), Siemens, GE Fanuc, Omron and many others.

Most important of all, the HMC7000 Series is specifically designed for harsh industrial environments. Every unit is rated for CE (European Noise Immunity/Emissions standards), NEMA 4 rating, and UL listed for installations requiring a Class I Division 2 product.

Models Available

Below are the basic models currently available from Maple Systems.

Model	Display Size	Description
HMC7030A-L 	3" LCD, 128x64 pixels, with tri-color (Red, Green, Blue) display	18 membrane-style (no touchscreen) keys, 1 serial port, 1 USB slave port, 12 digital inputs and 8 digital outputs built-in, no expansion slots
HMC7030A-M 	2.7" LCD, 128x64 pixels, with tri-color (Red, Green, Blue) display	18 membrane-style (no touchscreen) keys, 1 serial port, 1 USB slave port, no local inputs/outputs, three expansion slots
HMC7035A-M 	3.5" TFT 32K color display, 320x240 pixels, LED backlight	6 membrane-style keys, touchscreen, 1 serial port, 1 USB slave port, 1 USB host port, no local inputs/outputs, three expansion slots
HMC7057A-M 	5.7" TFT 32K color display, 320x240 pixels, LED backlight	6 membrane-style keys, touchscreen, 2 serial ports, 1 USB slave port, 1 USB host port, no local inputs/outputs, five expansion slots

These are the currently available expansion modules for the models listed above (except for the HMC7030A-L). Contact Maple Systems if you need a module not listed.

Expansion Module	Description
HMC7-MI-01	16 digital inputs (sink or source)
HMC7-MI-02	4 analog inputs [Resolution: 16 bit] (20mA or 10V)
HMC7-MO-01	12 relay outputs (2A per contact)
HMC7-MIO-01	8 digital inputs (NPN or PNP) and 8 digital outputs (NPN transistor) (Rating: 0.5A)
HMC7-MIO-02	8 digital inputs (NPN or PNP) and 8 digital outputs (PNP transistor) (Rating: 0.5A)
HMC7-MIO-03	2 relay inputs [Resolution: 12 bits] (20mA or $\pm 10V$) and 2 relay outputs [Resolution: 12 bits] (20mA or +10V)

Note: Detailed Specification Sheets and Cutout Drawings are available for download from www.maplesystems.com.

Installation

CE Compliance

The HMC7000 Series Graphic HMCs have been tested to conform to European CE requirements, which meet or exceed the noise emissions and immunity requirements as set forth in the EN55022 (Emissions) and EN55024 (Immunity) standards. The products are designed to withstand electrical noise in harsh industrial environments. They also conform to requirements that limit electrical emissions. However, this does not guarantee that the products will be totally immune from possible malfunction in cases where severe electrical noise occurs. Therefore, we strongly recommend that you follow the guidelines outlined in this guide for proper wire routing and grounding to insure the proper operation of your graphic HMC.

Environmental Considerations

The HMC7000 Series is designed to operate in temperatures from 0° to 50°C (32° to 122°F). It is intended for indoor installations and may not be suitable for use in certain outdoor applications. Make sure that the unit is installed correctly and that the operating limits are adhered to (see Specifications from Maple Systems website). Avoid installing the HMC7000 Series in environments with severe mechanical vibration or shocks. Do not install the HMC in enclosures with rapid temperature variations or high humidity. Either will cause condensation of water inside the device and eventual damage to the HMC. Highly humid areas are also to be avoided. High humidity causes condensation of water in the unit.





Do not operate the HMC7000 Series in areas subject to explosion hazards due to flammable gases, vapors or dusts.

NEMA Rating

The HMC7000 Series is rated for NEMA 4/12 (indoor) or IP65 installations. This means that when the HMC is properly mounted to a NEMA 4 panel or other NEMA 4 rated enclosure, the front enclosure of the HMC will provide protection to the inside of the panel from splashing water, wind-blown dust, rain, or hose-directed water. The HMC must be installed according to the instructions in this manual to be properly sealed.

Safety Precautions

Please observe the following precautions when installing the HMC. Failure to comply with these restrictions could result in loss of life, serious personal injury, or equipment damage.

-  **Warning:** Do not operate the HMC in areas subject to explosion due to flammable gases, vapors, or dusts
-  **Warning:** Do not connect the HMC to an AC power source. You will cause permanent damage to the HMC.
-  **Warning:** Do not attempt to use a DC power supply that does not meet HMC power requirements. You may cause malfunction or permanent damage to the HMC.
-  **Warning:** Do not power the HMC with a DC power supply used for inductive loads or for input circuitry to the programmable logic controller. Severe voltage spikes caused by these devices may damage the HMC.

Location Considerations

Care should be taken when locating equipment behind the HMC7000 to ensure that AC power wiring, PLC output modules, contactors, starters, relay and any other source of electrical interference are located away from the HMC7000. Particular care should be taken to locate variable speed drives and switching power supplies away from the HMC.

Control Panel Design Guidelines

Panel Preparation

A metal panel or mounting surface is required. The minimum thickness should be 15 gauge (0.059 in/3.3 mm) if cold-rolled steel or hardened steel is used. Use 10 gauge (0.101 in/2.6 mm) if aluminum alloy (6061-T6 preferred) is used. Thinner panels or surfaces may bow between the mounting clamps and not form a seal with the gasket. Make sure all supplied mounting clamps are used and that the panel does not flex or bow more than 0.010 in. to ensure a proper seal. Maximum thickness should be no more than 0.26" or 6.5mm.

The HMC should be mounted into a panel with a depth of at least 4 in. (105 mm). Allow a clearance of at least 1 in. (25 mm) on each side for mounting hardware. Consider proper clearance for cable connections when mounting.

NOTE: Cutout dimensions for each particular HMC model are readily available for download from the Support Center- Dimensional Drawings section of the Maple Systems website

Warning: The HMC requires a stiff, flat, smooth mounting surface free of blemishes, scratches, or pits in order that the gasket seal properly to NEMA 4. If the panel or mounting surface is not uniform, thick, flat, stiff, or smooth enough, then a sealant such as silicone may be required.

NOTE: Clean and deburr the panel cutout before the HMC is installed

Pay careful attention to the placement of system components and associated cable routing. These items can significantly enhance the performance and integrity of your control application.

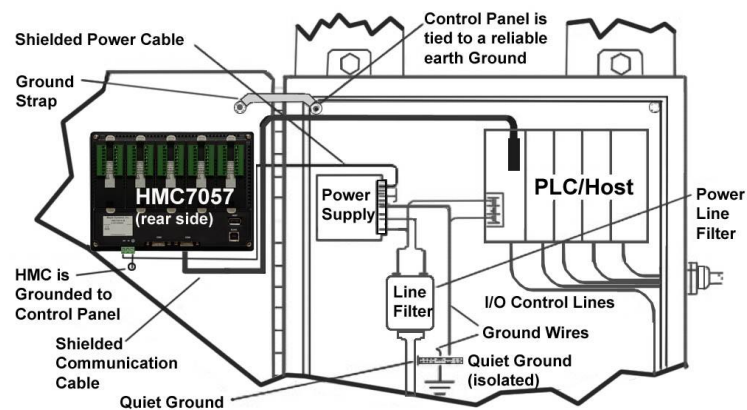
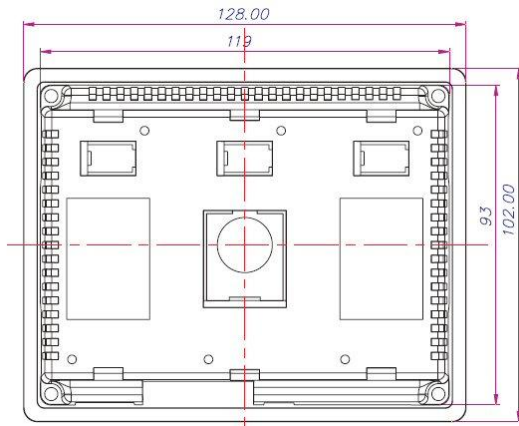

Figure 1: Typical Panel Layout

Mounting the HMC onto a panel

Panel Cutout and Mounting for the HMC7030 and HMC7035 models:

Below is the panel cutout (4.69"x3.67" [119x93 mm]) and mounting dimensions for all 3.5" and 2.7" LCD models:



Note: the maximum panel thickness should be at least 0.26" [6.5mm] (tolerance ± 0.0004 " [± 0.01 mm])

► Procedure to mount the unit:

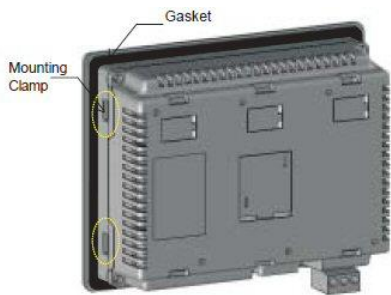

Figure 1

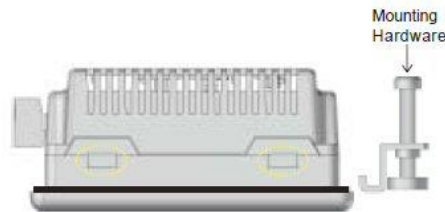

Figure 2



Figure 3



Figure 4

- Make a cutout in the panel to the required size.
- Place the unit into the panel. The sealing gasket is placed directly behind the HMC bezel. (Note: use a sealing adhesive in installations in which the panel surface is rough or uneven).
- On each HMC, there are four mounting slots. Four mounting clamps (with clamp, bolt, and cap nut) are included with each HMC. Insert each clamp into the mounting slots. Hold the unit in place, while you tighten the mounting bolts evenly (to about 0.5 lb-ft of torque).

Caution: Do not over-tighten the screws beyond snugness or you may damage the housing or warp the overlay.

Panel Cutout and Mounting for the HMC7057 models:

Below is the panel cutout (7.24"x5.16" [184x131 mm]) and mounting dimensions for all 5.7" LCD models:

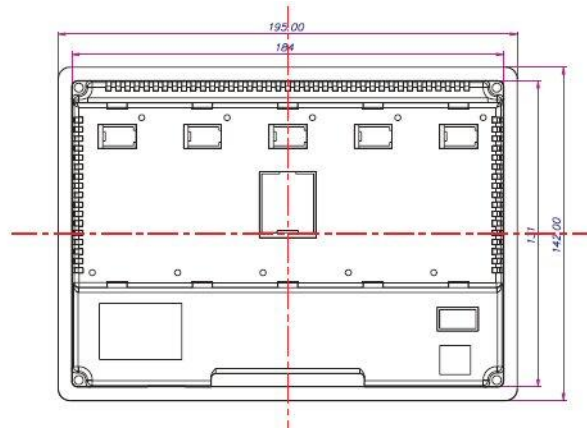

Note: the maximum panel thickness should be no more than 0.26" [6.5mm] (tolerance ± 0.0004 " [± 0.01 mm])

► Procedure to mount the unit:

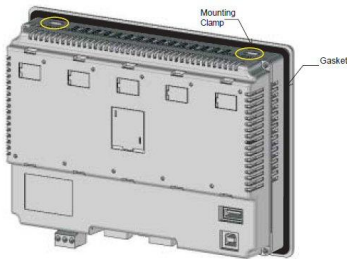

Figure 1

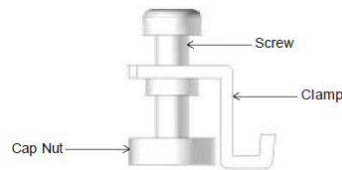

Figure 2

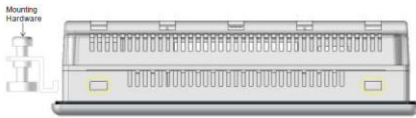

Figure 3

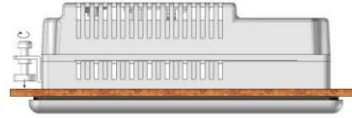

Figure 4



Figure 5 Make a cutout in the panel to the required size.

- Place the unit into the panel. The sealing gasket is placed directly behind the HMC bezel. (Note: use a sealing adhesive in installations in which the panel surface is rough or uneven).
- On each HMC, there are four mounting slots. Four mounting clamps (with clamp, bolt, and cap nut) are included with each HMC. Insert each clamp into the mounting slots. Hold the unit in place, while you tighten the mounting bolts evenly (to about 0.5 lb-ft of torque).

Caution: Do not over-tighten the screws beyond snugness or you may damage the housing or warp the overlay.

REINSTALLATION: If, at any time, you are required to reinstall an HMC into a panel, be aware that the gasket will take a 'set' to the panel and may no longer provide an adequate NEMA 4 seal. Therefore, for best results, we recommend that you replace the gasket if reinstallation is required.

Installing the I/O Expansion Modules

Mounting the expansion modules onto a HMC7000:

- The expansion modules have two (2) locking connectors as shown in the diagram below:

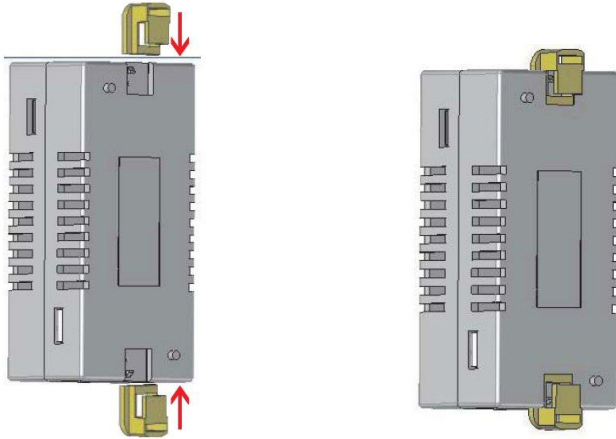

- Pull out the lock connectors to attach the I/O Expansion module to slots on the HMC7000:

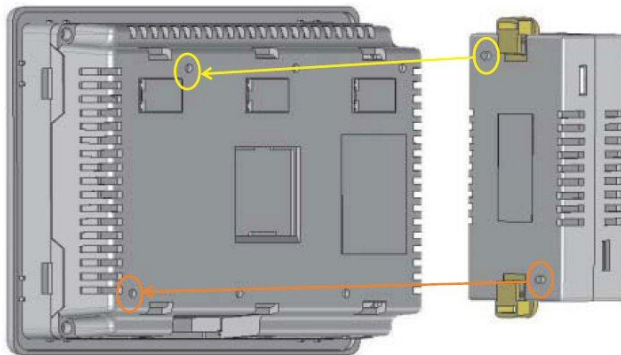

NOTE: you must remove the protective tab directly below the 'Expansion Port #' label so that the I/O Expansion interconnect plug can attach to the HMC7000 socket.

- Push down the lock connectors to safely secure the I/O Expansion module:



To remove the expansion module, simply pull out the lock connectors (on both sides) and gently pull the module apart from the HMC.

Control Panel Grounding

The control panel must be connected to a good, high-integrity earth ground both for safety considerations and shielding purposes. Maple Systems cannot overemphasize the importance of good grounding. If you fail to use good grounding procedures during installation, sporadic malfunction of the HMC may occur. Connect the HMC chassis ground terminal to a reliable earth ground with a low-resistance path.

Route all earth ground wires that lead from the HMC, the PLC, the power supply, and the line filter to a central earth ground point such as a barrier strip. This will ensure that no ground current from one device influences the operation of the other devices.

Connect the HMC chassis ground terminal to the control panel door using a heavy-gauge short braided cable or ground wire to minimize resistance. Connect the power cable's shield wire to the HMC chassis ground terminal. Connect the control panel to earth ground using a copper grounding rod close to the HMC and control panel.

Hinged doors on control panels do not provide a long-term electrical connection to the rest of the enclosure. Corrosion develops over time and prevents good electrical contact. For this reason, a separate wire braid should be installed from the hinged control panel to the rest of the enclosure.

For a more in-depth overview of ground wiring techniques, refer to Technical Note #1027, "OIT Ground Wiring and Electrical Noise Reduction," which you can find in the Tech Notes section on our web site.

Connect HMC Chassis Ground to Control Panel

To reduce the possibility of electrical interference, connect the chassis ground terminal of the HMC to a clean earth ground. Ensure that the HMC is grounded separately from other high-power systems. Use a single-point ground if grounding more than one unit.

If the control panel is metal, make sure it is properly grounded. Then connect a short heavy gauge wire (#14 AWG) from the chassis ground terminal of the HMC to a mounting bolt on the control panel door. The mounting bolt must have good electrical contact to the control panel; scrape away any paint that may be covering the panel to provide a good connection.

NOTE: If the control panel is made of a non-conductive material, it is essential that you connect the chassis ground terminal of the HMC to a clean earth ground point located close to the panel.

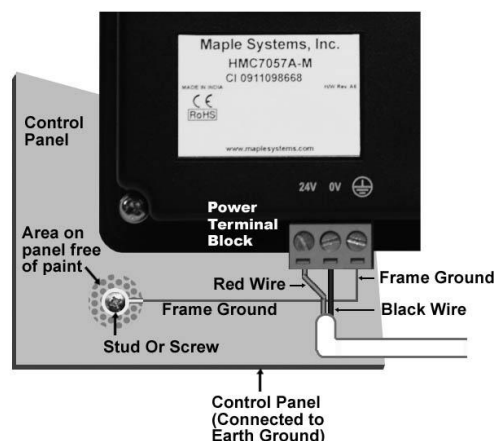

Figure 2: Chassis Ground Connection

NOTE: Do not use a ground that has an unstable impedance, such as a painted screws, or ground subject to vibration.

Power Supply Selection

The power supply used to power the HMC should provide an output of +24 VDC \pm 20% measured at the HMC power terminal block. A 24VDC regulated power supply *dedicated to the HMC* is recommended. Use a power supply with adequate current rating based upon your particular model (visit the Support Center Specifications page on our website).

Do not use the power supply used to provide power to the HMC to power switching relays, solenoids, or other active devices. Use appropriate surge suppression devices in areas subjected to lightning or power surges. Keep AC lines, high energy equipment cables and rapidly switching DC wiring separate from the HMC power and signal wires.

Connecting high voltages or AC power mains to the DC input will make unit unusable and may create an electrical shock hazard to personnel. Such a failure or shock could result in serious personal injury, loss of life and/or equipment damage.

DC voltage sources should provide proper isolation from main AC power and similar hazards.

A power line filter installed at the AC input to the HMC power supply is highly recommended as a safeguard against conducted RF noise, which is often present on factory power lines. The wires connecting the output of the power line filter to the power supply should be kept as short as possible to minimize any additional noise pickup. The case of the power line filter should be connected to a quiet earth ground. The power line filter should have a current rating of at least 3 Amps with common mode and differential mode attenuation. In applications that may have high frequency noise present, we also recommend using a resistor (\sim 1 M Ω) and capacitor (\sim 4700 pF) in parallel to clean earth ground on the DC output of the power supply.

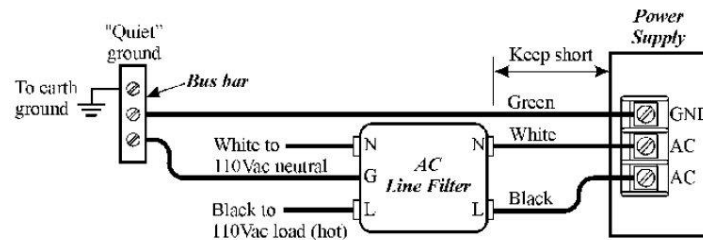

Figure 3: Power Line Filter Connection

Cable Routing and Noise Immunity

Follow these guidelines when routing cables to the HMC:

- Always route the HMC communication cable and the power cable away from any AC voltage or rapidly switching DC control lines.
- Never bundle the HMC cables together with 120VAC power wires or with relay wiring.
- Try to keep at least 8 inches (20 cm) of separation between the HMC cables and other power wiring. If voltages greater than 120VAC are used in the system, greater separation is required.
- If the HMC cables must come near AC wiring, make sure they cross at 90 degrees.
- Run AC power wires in a separate grounded conduit to reduce electrical noise interference.
- Keep the cable lengths for the HMC as short as possible. Do not coil excess cable and place it next to AC powered equipment.
- Cover any equipment used in the enclosure that operates at high frequency or high current levels with a grounded metal shield.

Connect the HMC to Power

Use the separate 3-position terminal block supplied to provide power to the HMC.

The power cable for the HMC should be 18AWG, 2-conductor wire with a shield drain wire and protective shield (foil/braid). You may buy cable P/N 6030-0009 by the foot from Maple Systems to make your own power cable.

Always run the DC ground wire directly back to the signal return of the power supply. *Do not use the chassis ground wire as your signal return.*

Caution: To prevent possible damage to the HMC, we recommend waiting ten seconds after removing power to the HMC before applying power again.

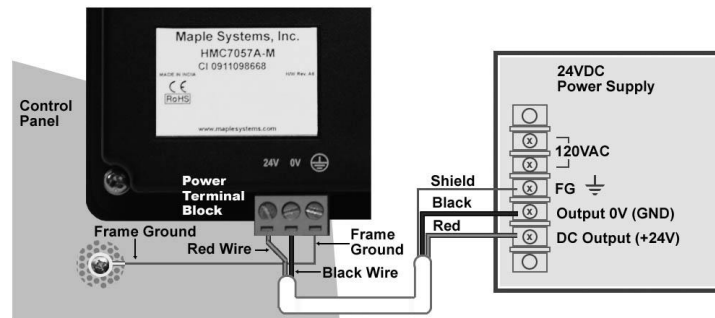
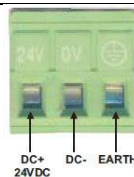

Figure 4: HMC Power Wiring

To connect the HMC to power:

1. Connect the power cable to the HMC.
 - a. Strip cable shield to expose 2" of the black/red wires.
 - b. Strip ¼" of insulation from the black/red wires.
 - c. Connect red wire to the 24V DC positive (+) input.
 - d. Connect black wire to the 24V DC negative (-) input.
 - e. Connect power shield wire to chassis ground input.
2. Route the power cable to the HMC power supply. The power cable should not be any longer than necessary.
3. Install the power supply wires as follows (with colors shown for Maple Systems cable P/N 6030-0009):

Color	Power Supply	HMC
Red	+Output/+24VDC	+24V
Black	-Output/+24VDC return	GND
Shield	Case ground	FG or Earth



NOTE: The power connector on the HMC7000 Series uses a 3-position terminal block with screw-down clamps. Lugs are not required

Communication Ports

The HMC7000 Series supports four types of communication ports.

Serial Ports

COM1 port

The COM1 port supports RS232, RS422 four-wire and RS485 two-wire connections. RS485/RS422 supports multi-drop network (depending on protocol driver selected):

DE9S female connector

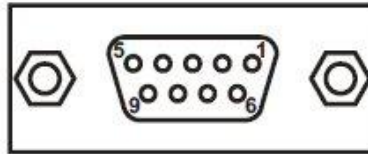

Pin out Diagram COM1:

Pin Number	Name	Description
1	TX+	RS422 transmit +
2	TXD	RS232 transmit
3	RXD	RS232 receive
4	RX+	RS422 receive +
5	GND	Ground
6	NC	No connection
7	NC	No connection
8	TX-	RS422 transmit -
9	RX-	RS422 receive -

Note: for 2 wire RS485, jumper Pins 1 (TX+) and 4 (RX+).

Also jumper Pins 8 (TX-) and 9 (RX-).

COM2 port (HMC7057 model only)

The COM2 port on the HMC7000 Series supports RS232, RS422 four-wire and RS485 two-wire connections. The RS485/RS422 connection can be used in multi-drop network communications (provided the protocol driver selected supports this):

DE9S female connector

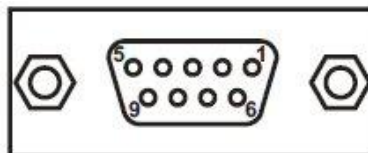

Pin out Diagram COM2:

Pin Number	Name	Description
1	TX+	RS422 transmit +
2	TXD	RS232 transmit
3	RXD	RS232 receive
4	RX+	RS422 receive +
5	GND	Ground
6	NC	No connection
7	NC	No connection
8	TX-	RS422 transmit -
9	RX-	RS422 receive -

Note: for 2 wire RS485, jumper Pins 1 (TX+) and 4 (RX+).

Also jumper Pins 8 (TX-) and 9 (RX-).

Configuration Wiring

To configure the HMC7000 using the MAPware-7000 software, you need a configuration cable (USB or RS232) for your HMC. Please refer to the Maple Systems website to select a download cable.

Ethernet

Ethernet is not available on any of the HMC7000 Series models but new models are under development. If an Ethernet port is a requirement for your project, please contact Maple Systems for information on new models.

USB Client port

This port is used solely for downloading/uploading projects into the HMC7000 unit. The port complies with the USB 2.0 specification, and has a Type B female connector.

USB Host port (not available on the HMC7030 models)

This port is used for data logging and historical alarms when you attach a USB Flash Drive. It is compliant with USB 2.0 specification.

Connecting to Peripherals

I/O Expansion Modules

The HMC7000 Series (except for the HMC7030A-L) support I/O expansion modules. These modules are used to connect directly to digital/analog inputs and outputs in an industrial system.

Below is a list of the current I/O expansion modules supported:

I/O Module Part No.	Description
HMC7-MI-01	16 Digital Inputs (sinking or sourcing)
HMC7-MI-02	4 Analog Inputs (0-10 V, -10 to +10V, 0-20mA, 4-20mA)
HMC7-MO-01	12 Digital Outputs (Relay type)
HMC7-MIO-01	8 Digital Inputs (PNP or NPN), 8 Digital Outputs (NPN 0.5A)
HMC7-MIO-02	8 Digital Inputs (PNP or NPN), 8 Digital Outputs (PNP 0.5A)
HMC7-MIO-03	2 Analog Inputs (0-10 V, -10 to +10V, 0-20 mA, 4-20mA), and 2 Analog Outputs (0-10 V, 0-20mA, 4-20mA)

* For more detailed specifications on each I/O module, see HMC7000 Programming Manual

Common Terms for I/O Modules

This section defines some common terms that are used to describe various types of input and output modules. The terms explained below are generic descriptions. Be sure to consult the datasheet for the I/O module you use for specific requirements when installing and wiring the module.

Digital Modules

Expansion modules that have digital inputs and/or digital outputs are termed 'digital modules'. The term 'digital' signifies that the signal is interpreted by the module to be discrete levels, either an ON state (1) or OFF state (0). Each digital input contact is tagged to an internal Input Coil (X) in the tag database of the HMC7000. Similarly, each digital output contact is tagged to an Output Coil (Y).

Analog Modules

Expansion modules that have analog inputs and/or analog outputs are termed 'analog modules'. The term 'analog' denotes that the signal is interpreted by the module as an analog signal with continuous (not discrete) levels, depending upon the resolution. The signal level varies according to current or voltage. Each analog input contact is tagged to an internal Input Register (XW) in the tag database of the HMC7000. Similarly, each analog output contact is tagged to an Output Register (YW).

Sinking versus Sourcing Inputs

These terms are used to indicate the method of wiring inputs and outputs of DC modules. Any module that is not bidirectional (meaning current can go in either direction) requires that the circuit attached to each module contact (i.e. input or output) conduct current in a specific direction (sink or source). Each circuit attached to the contact must have a

power supply and a field device (either some type of device that acts as a switch for inputs or a load in the case of an output).

For a source connection, the current flows out of the expansion module's input/output contact and into the common (signal ground) contact. In other words, the I/O contact on the expansion module 'sources' or provides the current to the switch contact or load.

A sink connection causes the current to flow into the expansion module's input/output contact and out of the common contact on the I/O module. In other words, the I/O contact 'sinks' or takes in the current from the switch contact or load:

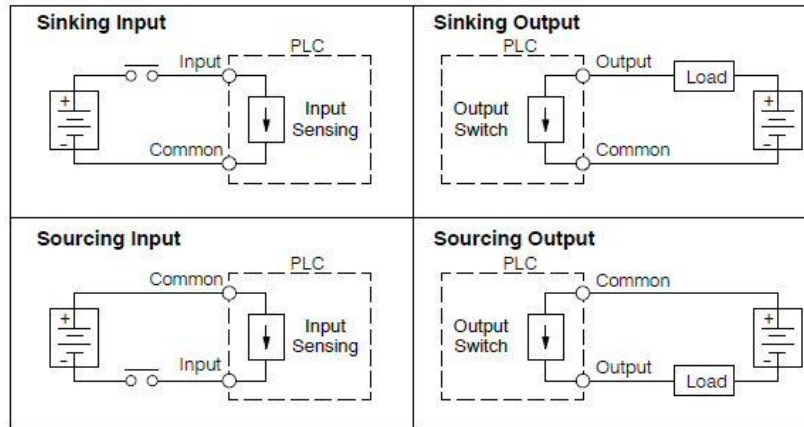

Note: arrow indicates current flow direction

In order to have current flow, each I/O contact on the expansion module must have a return path or a signal ground connection. In most modules, the signal ground connection is shared by multiple I/O contacts, hence the name 'common'.

Each I/O contact is labeled for easy identification on the modules. As we mentioned above, 'COM' is the common ground contact. A contact with an 'X' followed by a number is an input contact and a contact with a 'Y' followed by a number is an output contact. The number refers to the position associated with each contact in the I/O module.

When you create your application project in MAPware-7000, you will have to assign a bit/register memory address for each contact on the expansion module. MAPware-7000 provides you with the option to allow the software to do this automatically. In this case, it will assign memory addresses according to the position and expansion slot in which the I/O module is located.

In addition, many of the I/O modules have a three-pin connector that is used to connect a voltage source (usually +24VDC). This voltage source drives the output contacts of the I/O modules.

Digital Outputs (PNP or NPN type)

The output contacts of a digital I/O module use an optically isolated PNP or NPN transistor internally to open/close the connected load to the attached 24VDC power source. PNP/NPN outputs are faster than relay outputs but can only work with low current DC loads (typically 500mA max per contact). In a PNP-type contact, the load end not connected to the output contact is connected to the common (V-) terminal of the voltage source. A NPN-type contact has the load end connected to the positive (V+) terminal of the voltage source:

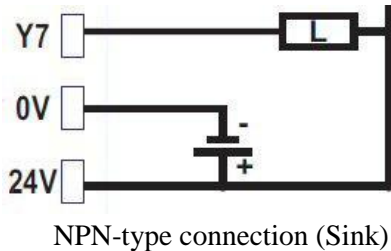
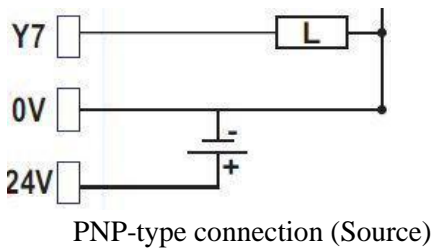

Note: the above diagrams show that a PNP output is ‘sourcing’ current and the NPN output is ‘sinking’ current.

Which output (NPN or PNP) to use often depends upon the type of load connected. Also, PNP-type outputs are more vulnerable to a ground short which can damage the output module. A ground short to an NPN-type output does not damage the output module.

Digital Outputs (Relay type)

The output contacts of a relay-type digital module are typically used to control loads that require an AC power source:

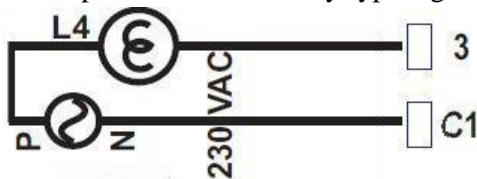

If you need to connect a DC load that requires more current than the maximum available when using a PNP/NPN-type output, this is an option. For AC loads, each relay output contact can typically handle up to 230VAC with a 2A per contact load. For DC loads, each relay output contact can typically handle a 2A per contact load for up to 30VDC.

Analog Voltage Ratings

The 0 to 10 VDC voltage rating is applied to analog inputs and outputs. With analog inputs, the analog module writes a data value to the assigned register (XW) based upon the measured DC voltage at the input (0 to 10 volts). Resolution varies but is typically 16 bits (meaning a data value of 0 equates to a measurement of 0 volts, and a data value of 65535 equates to a measurement of 10 volts). Analog outputs can deliver a DC voltage of 0 to 10 volts to a load with a minimum resistance of 1000 ohms depending upon the value in the assigned register (XY). Some analog input modules can also be configured to measure DC voltage ranges of -10 to +10 volts, 0 to 100 millivolts, or 0 to 50 millivolts.

Analog Current Ratings

The 0 to 20 mA current rating is applied to analog inputs and outputs. With analog inputs, the analog module writes a data value to the assigned register (XW) based upon the measured DC current at the input (0 to 20 milliamps). Resolution varies but is typically 16 bits (meaning a data value of 0 equates to no current, and a data value of 65535 equates to a measurement of 20 mA). Analog outputs can deliver a DC current of up to 20mA to a load with a maximum resistance of 500 ohms based upon the data value in the assigned register (XY). Some analog input/output modules can also be configured to measure 4-20mA ranges.

Installing I/O Modules

The expansion modules for the HMC7000 are designed to snap onto the back enclosure of the HMC7000 thru expansion slots. The HMC7030A-M and HMI7035A-M units support up to three modules. The HMC7057A-M unit supports up to five modules.

Programming the I/O Modules

The I/O expansion modules for the HMC7000 Series must be assigned to the proper slot location using the MAPware-7000 configuration software. Note that any project downloaded into a HMC7000 model whose configuration of I/O modules does not match the physical configuration of the unit will not run. Therefore, it is important to properly configure your MAPware-7000 project.

Regardless of the particular HMC7000 model you are using, the steps to configure the I/O modules is very similar:

1. Open a new project and select which product you wish to use. Click OK.
2. On the Project Configuration dialog box, enter the appropriate information and then click OK.
3. In the Project Information Window, click on the I/O Allocation folder, and then click on the Expansion folder.

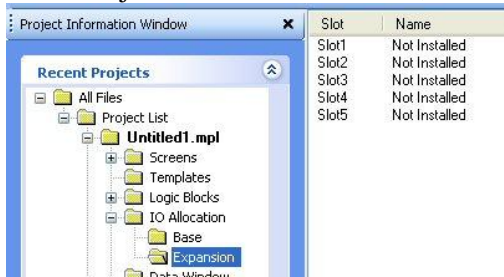

4. Double-click on Slot 1 to display the IO Allocation dialog:

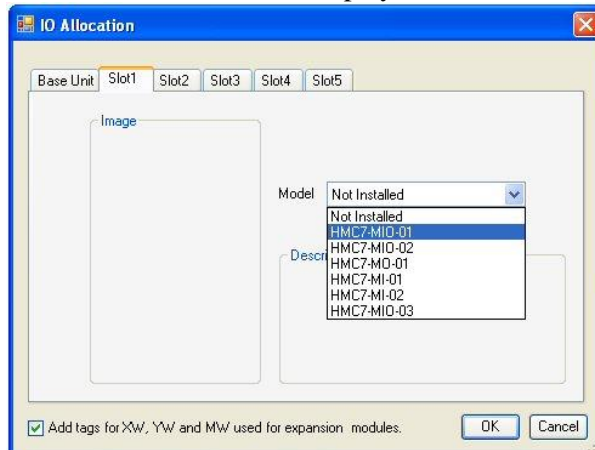

5. Select from the list box, the particular I/O expansion module installed into Slot 1 of the HMC7000. Notice the checkbox to 'Add tags for XW, YW, and MW'. When checked, the MAPware-7000 automatically assigns tag addresses to the Tag Database for the I/O module. The tag addresses are configured based upon the module and the slot location. Make sure this box is checked, and then click OK.



6. Notice that Slot1 is now identified with the proper IO module, along with a description and memory address allocation. You can also take a look at the Tag Database to see the tags created for Slot 1 module:

Tag No	Tag Name	Port	Tag Address	Byte(s)	Node Name	Tag Type
1	HSC Enable Bit (CH1)- Slot01	-	M01080	bit	Operator Panel	User Defined Tag
2	HSC Reset Bit(CH1)- Slot01	-	M01081	bit	Operator Panel	User Defined Tag
3	HSC Enable Bit (CH2)- Slot01	-	M01176	bit	Operator Panel	User Defined Tag
4	HSC Reset Bit(CH2)- Slot01	-	M01177	bit	Operator Panel	User Defined Tag
7	HSC Configuration register(CH1)- Slot1	-	Mw0100	2	Operator Panel	User Defined Tag
8	High Speed Counter (HSC) Register (CH1)- ...	-	Mw0101	4	Operator Panel	User Defined Tag
9	HSC Preset Register (CH1)- Slot01	-	Mw0103	4	Operator Panel	User Defined Tag
10	HSC Configuration register(CH2)- Slot01	-	Mw0106	2	Operator Panel	User Defined Tag
11	High Speed Counter (HSC) Register (CH2)- ...	-	Mw0107	4	Operator Panel	User Defined Tag
12	HSC Preset Register (CH2)- Slot01	-	Mw0109	4	Operator Panel	User Defined Tag
74	Slot1_InputCoil_00000	-	X01000	bit	Operator Panel	User Defined Tag
75	Slot1_InputCoil_00001	-	X01001	bit	Operator Panel	User Defined Tag
76	Slot1_InputCoil_00002	-	X01002	bit	Operator Panel	User Defined Tag
77	Slot1_InputCoil_00003	-	X01003	bit	Operator Panel	User Defined Tag
78	Slot1_InputCoil_00004	-	X01004	bit	Operator Panel	User Defined Tag
79	Slot1_InputCoil_00005	-	X01005	bit	Operator Panel	User Defined Tag
80	Slot1_InputCoil_00006	-	X01006	bit	Operator Panel	User Defined Tag
81	Slot1_InputCoil_00007	-	X01007	bit	Operator Panel	User Defined Tag
82	Slot1_InputReg_00000	-	Xw0100	2	Operator Panel	User Defined Tag
83	Slot1_OutputCoil_00000	-	Y01000	bit	Operator Panel	User Defined Tag
84	Slot1_OutputCoil_00001	-	Y01001	bit	Operator Panel	User Defined Tag
85	Slot1_OutputCoil_00002	-	Y01002	bit	Operator Panel	User Defined Tag
86	Slot1_OutputCoil_00003	-	Y01003	bit	Operator Panel	User Defined Tag
87	Slot1_OutputCoil_00004	-	Y01004	bit	Operator Panel	User Defined Tag
88	Slot1_OutputCoil_00005	-	Y01005	bit	Operator Panel	User Defined Tag
89	Slot1_OutputCoil_00006	-	Y01006	bit	Operator Panel	User Defined Tag
90	Slot1_OutputCoil_00007	-	Y01007	bit	Operator Panel	User Defined Tag
91	Slot1_OutputReg_00000	-	Yw0100	2	Operator Panel	User Defined Tag
5	PLC module control	-	Mw00000	?	Operator Panel	Default Tag

Once memory addresses have been assigned to the module, you can then reference and use the module in your project.

For more information on wiring the I/O module, please check *Expansion Modules* appendix in the HMC7000 Series Programming Manual.

PLCs/Controllers

All of the HMC7000 Series have at least one serial port that can be used to connect to an external programmable logic controller (PLC). The MAPware-7000 configuration software supports most major PLC manufacturers including PLCs from Allen Bradley (Rockwell Automation), Schneider Electric (Modbus RTU), Siemens, Omron, and GE Fanuc. Finally, many of the HMC7000 models have two serial ports which allow simultaneous connections to two PLCs. Each serial port is individually configured so that you are not restricted to using only one PLC communications driver.

Connecting to a PLC

As mentioned above, an external PLC can be connected to the HMC7000 Series via a serial port using RS232, RS422 four wire, or RS485 two wire connections.

In addition to making the physical connection to the external PLC, you must also configure the communications parameters (i.e. communications driver, baud rate, etc.) using the MAPware-7000 software:

1. Open a new project and select which product you wish to use. Click OK.
2. On the Project Configuration dialog box, click on the COM1/COM2/Ethernet tabs to configure the HMC7000 communication port attached to the external PLC:

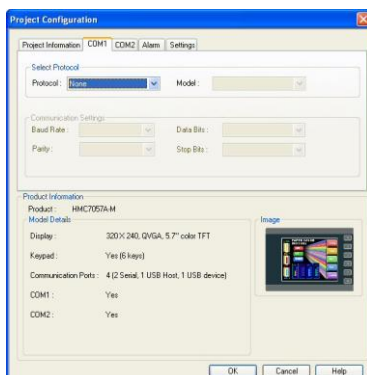

In the Select Protocol section, choose from the Protocol list box the appropriate protocol driver for your PLC. Click on the Model list box to select the particular PLC model that most closely matches your PLC.

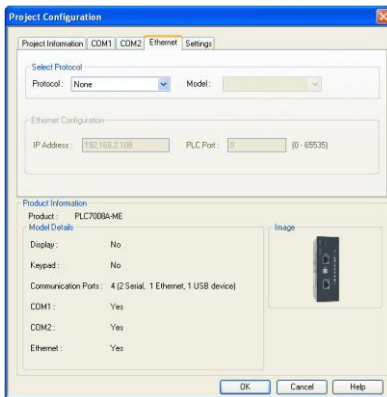

- In the Communication Settings section, enter the communications parameters that the HMC7000 will use to attempt communications with your external PLC. For more specific information about each external PLC supported, please visit our Support Center-Controller Info Sheets at our website: www.maplesystems.com.
- Click OK. Please note that you can check or adjust your settings by clicking on the Network Configuration folder in the Project Information Window:

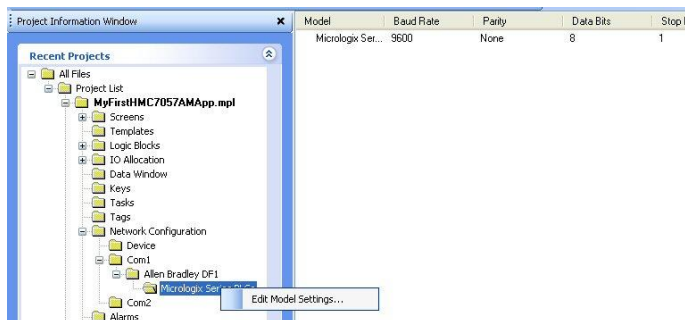

- Simply right-click on the PLC driver to display the Edit Model Settings dialog box:

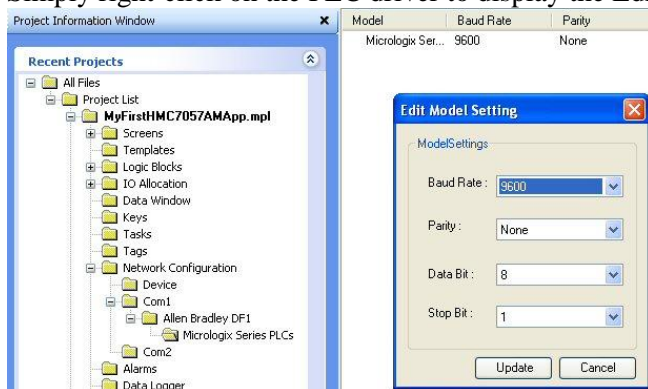

- Note that you do not have to assign the external PLCs at the time that a new project is created. You can always add the drivers later using the Project Information Window by right-clicking the appropriate Com port:

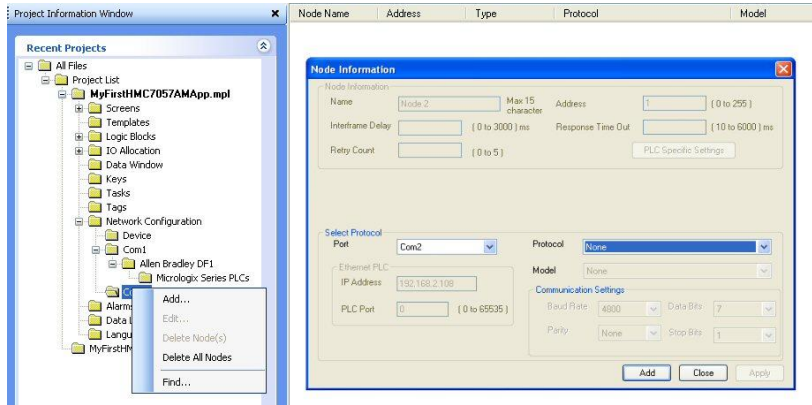

After assigning an external PLC to one of the COM ports on the HMC7000, you can read/write to the internal memory of the attached PLC. To do this, you must first assign tags to the PLC memory using the tag database:

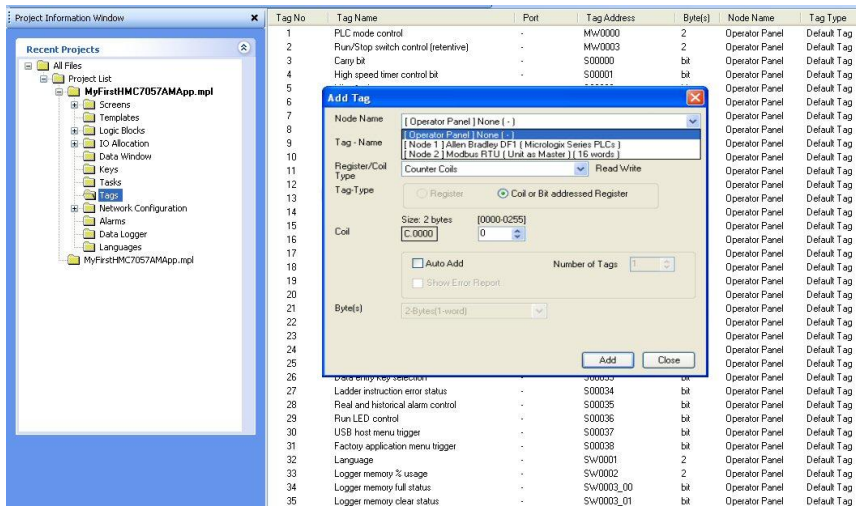

Once PLC memory addresses have been assigned to the tag database, you can then read/write to the PLC in your project.

Serial Printer

The MAPware-7000 software supports the ability to assign a serial printer to one of the serial Com ports on the HMC7000. This is done in much the same way as assigning an external PLC (see last section):

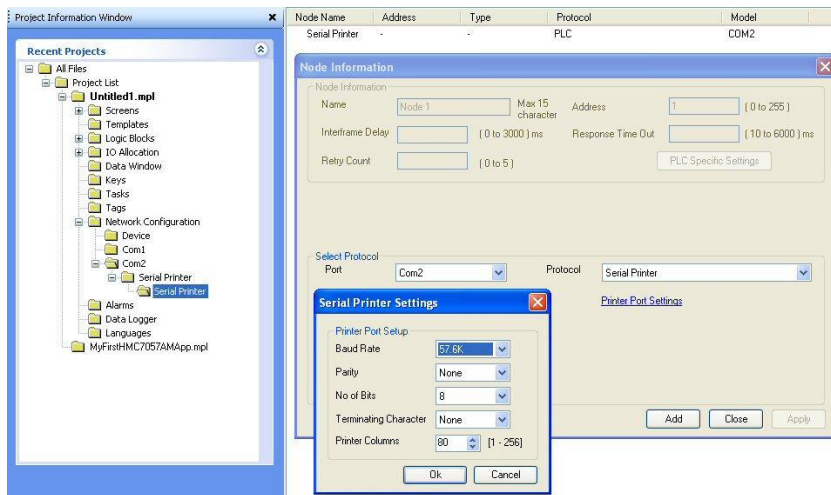

Attributes:

Port: select which serial COM port is connected to the printer.

Printer Port Settings- click on this option to set communications parameters.

Baud Rate- baud rate setting for the serial printer

Parity- parity setting for the serial printer

No of Bits- the number of data bits set on the serial printer

Terminating Character- the type of terminating character issued by the serial printer after reaching the end of the columns. Default is *None*.

Printer Columns – the total number of columns or number of characters printed before the terminating character is issued. Range is 1 to 256, default is 80.

Note: when printing a screen, the HMC7000 can only print text characters that appear on the screen- no graphics. You can send data to the serial printer in a number of ways:

- Set the Screen Print Properties attribute for a screen
- Use a Function Key to Print Data
- Set a Function Key to Key Specific Task-Print Group

USB Flash Drive

Each HMC7000 model has a built-in USB Device (Slave) port with a Type B socket connector. This port is used solely for uploading/downloading projects to the unit using a USB cable attached to the USB port on your computer.

The HMC7057A-M and HMC7035A-M models also have a USB Host port with a Type A receptacle connector. This port can be used to upload/download projects that have been loaded onto a USB Flash drive. This port is also used by the Data Logger feature.

Uploading/Downloading Projects via Flash

In addition to uploading/downloading a project through the customary method of connecting a USB cable to a computer that contains MAPware-7000, you can also use the USB Host port on the HMC7057A-M or HMC7035A-M model to upload/download projects using a USB Flash Drive. The Flash Drive must be formatted as FAT32. Although Maple Systems has not tested every Flash Drive manufactured, Flash Drives from the following manufacturers have been found to work with the HMC7000 units:

- PNY: Attaché (4-8GB)
- SanDisk: Cruzer Micro (2-8GB)
- Transcend: JF V30 (1-8GB)
- Kingston: Data Traveler (4-8GB)
- Sony: Micro Vault (2-8GB)

When using a Flash Drive with your HMC7000 unit, make sure that all important data is backed up to a safe location on another storage medium.

Before you can upload/download a project, the HMC must have a project running that contains a screen with a Set Bit button object. This object is tagged to internal memory bit S00037 – the USB Host Menu trigger:

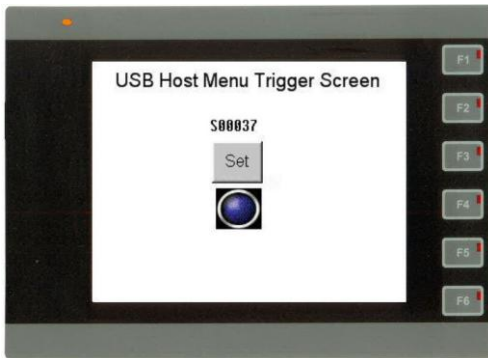

Note: this is just an example; you can create any type of screen as long as you have a Set Bit object that is tagged to S00037.

When the project is running, the operator must press the Set button to set internal coil address S00037 (make sure that a Flash Drive is inserted into the USB Host port of the HMC). This displays the following screen on the HMC:



Click the Yes button to display the next screen in sequence:

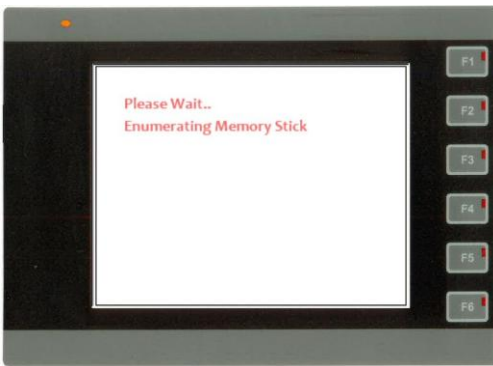

After a few moments, the following screen is displayed:

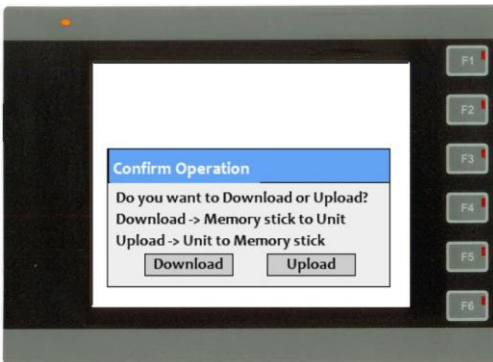

Uploading a HMC project onto a Flash Drive

Click the Upload button on the HMC screen if you wish to transfer a project currently located in the HMC7000 to an attached Flash Drive.

The following screen appears:



Options include:

- Application –uploads only the application project to the flash drive. The project is saved as an *.MPL file.
- Application + Logged Data –uploads the project and any data logged.
- Fonts – uploads the font files used to create all text objects. The font files are saved as FONT_File.BIN.
- Firmware – uploads the firmware for the HMC7000. The firmware is saved as an *.ABS file.
- Application + Hist. Alarm – uploads the project and any historical alarm data collected.
- Ladder – uploads the ladder logic only.

Click one of the options above to proceed to upload:



Click OK to begin:

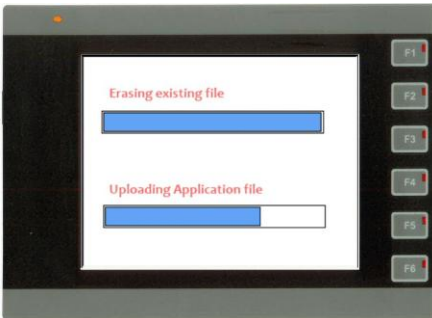

This process can take several minutes to complete. When completed, the following screen appears:



Click the OK button. The HMC7000 then displays the Upload Options screen. Click the Exit button. Unit will reboot and display the following:



Press the F2 function key on the HMC to run the internal project.

Downloading a HMC project from a Flash Drive

Click the Download button on the HMC screen if you wish to transfer a project located in the flash drive to the HMC. Note that this will delete whatever file that currently resides in the HMC7000.

The following screen appears:



Options include:

- Application – downloads only the application project (*.mpl) to the HMC7000
- Fonts – downloads the font file used to create all text objects
- Firmware – downloads the firmware to the HMC7000
- Ladder – downloads the ladder logic only

Click one of the options above to proceed to download:



Click OK to begin:



This process can take several minutes to complete.

When completed, the following screen appears:



Click the OK button. The HMC7000 then displays the Download Options screen. Click the Exit button. Unit will reboot and display the following:



Press the F2 function key on the HMC to run the internal project.

Now that you have a general knowledge of the hardware features for the HMC7000 Series, please consult the HMC7000 Series Programming Manual for information on how to use the many software features available.



Maple Systems Inc.
808 134th Street SW, Suite 120
Everett, WA 98204-7333
Phone: (425) 745-3229
Email: maple@maplesystems.com
Web: www.maplesystems.com

© 2011 Maple Systems Inc. All rights reserved.