

Digital flow transmitter for continuous flow measurement

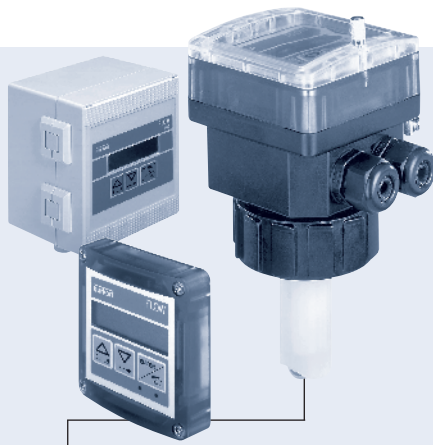

- Compact and remote version for pipe sizes 1/2" – 16", 145 PSI max.
- Shows both flow rate and volume (with two totalizers)
- Automatic-calibration: TEACH-IN
- Simulation: all output signals provided without the need for real flow

Type 8025 can be combined with...

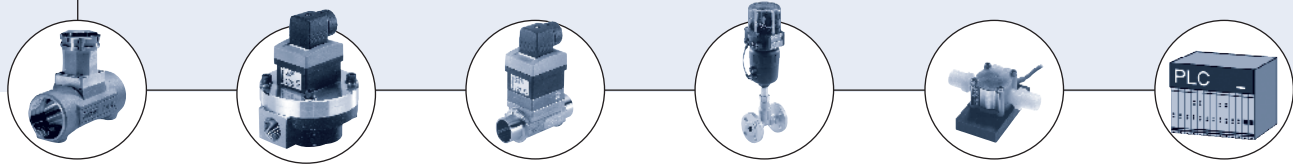

Type S020
Fitting

Type 8070
Positive displacement flow sensor

Type 8030
INLINE flow sensor

Type 2712 (8630)
Continuous TopControl

Type 8031
Flow sensor

PLC

The flow transmitter is specially designed for use in neutral and slightly aggressive, solid-free liquids.

The device is available in different models:

- Compact transmitter with paddle-wheel sensor: standard signal output, or battery powered indicator version.
- Remote universal transmitter for panel or wall mounting to connection to a flow sensor from the market; sensors with open collector output, relay reed output, TTL, CMOS or coil can be operated by this transmitter.
- Remote transmitter, for panel or wall mounting: standard signal output or battery powered indicator version, for connection to the Bürkert 8020/8030 sensor.

Technical data (common to the various versions)

General data

Display	15x60mm, 8-digit LCD, alphanumeric, 15 segments, 9mm high
----------------	---

Environment

Ambient temperature Operation and storage	32°F to 140°F (0°C to +60°C)
Relative humidity	≤80%, non condensated

Standard and approvals

Protection class	NEMA 4 (IP65)
Standard	CE
Approval	UL listed, CSA (for panel mount only)

DTS 1000094824 EN Version: A Status: RL (released | freigegeben | validé) printed: 09.02.2010

System versions

The compact version



combines a paddle-wheel flow sensor and an electronic module with a display in an IP65 enclosure. The output signals are provided via a 4-pole cable plug or a cable gland.

Burkert designed fitting ensures simple installation of the Burkert sensor into pipes from 1/2" to 16" (DN 15 to DN 400).

The panel-mounted version



consists of electronic module 8025 integrated in a front-cover. The associated separate flow sensor is a 8020, a 8030 with sinus or pulse signal (coil or hall transducer), or another flow sensor available from Burkert or the market.

The output signals are provided on a terminal strip.

The wall-mounted version



consists of electronic module 8025 in an IP65 enclosure. The associated flow sensor is a 8020, a 8030 with sinus or pulse signal (coil or hall transducer), or another flow sensor available from Burkert or the market.

The output signals are provided on a terminal strip via a cable gland.

Operation and display

The device can be calibrated by means of the K-factor, or via the TEACH-IN function. Customized adjustments, such as measuring range, engineering units, pulse output and filter are carried out on site.

The operation is specified according to two or three levels, depending on the transmitter version:

Flow transmitter (compact or remote)

Indication in operating mode/ Display

- flow
- output current
- main totalizer
- daily totalizer with reset function

Parameter definition

- language
- engineering units
- K-factor / TEACH-IN function
- measuring range 4-20 mA
- pulse output
- relay (option)
- filter
- reset main totalizer

Test

- alteration of basic adjustment (offset, span)
- frequency test of sensor
- flow simulation (dry-run test operation)

Battery indicator / totalizer (compact or remote)

Indication in operating mode/ Display

- flow
- main totalizer
- daily totalizer with reset function

Parameter definition

- language
- engineering units
- K-factor / TEACH-IN function
- filter
- reset main totalizer

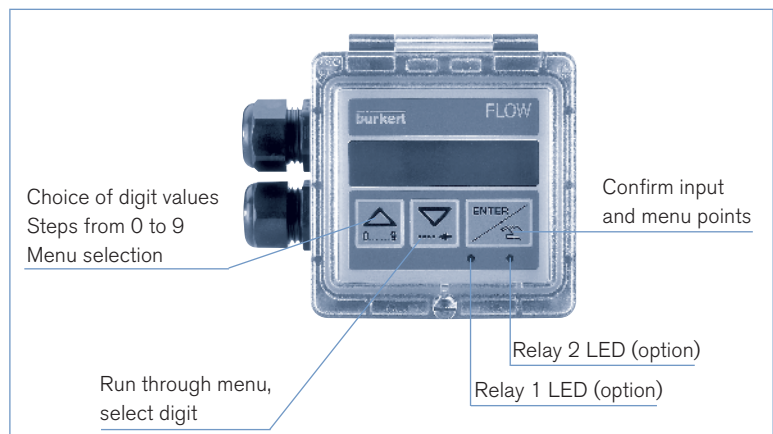

Compact transmitter Type 8025

The compact transmitter

is available in two versions:

- standard signal (4–20 mA, frequency)
- battery indicator/totaliser



Accuracy diagram

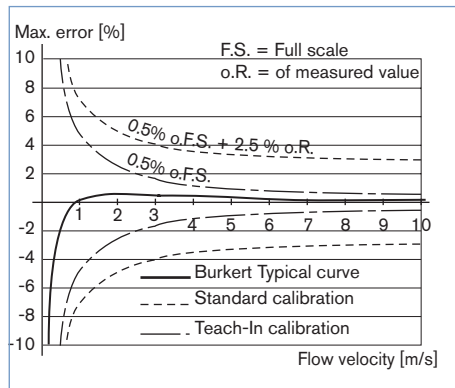

Design

When liquid flows through the pipe, the 4 magnets, inserted in the paddle-wheel set in rotation, produce a measuring signal in the transducer (coil or Hall sensor).

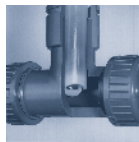

The frequency modulated induced voltage is proportional to the flow velocity of the fluid.

A conversion coefficient (K-factor, available in the instruction manual of the fitting), specific to each pipe (size and material) enables the conversion of this frequency into flowrate.

The electronic component converts the measured signal into several outputs (according to the transmitter version) and displays the actual value.

General data	
Compatibility	with all fittings S020
Materials	Housing, cover, lid, nut Front panel foil Screws Cable plug / gland Wetted parts materials Fitting Sensor holder, paddle-wheel Axis and bearing Seal
	PC Polyester Stainless Steel PA Brass, Stainless Steel 316L /1.4404 PVC, PP or PVDF PVDF Ceramics FKM (EPDM option)
Electrical connections	Cable grommet (DIN) plug EN 175301–803 or grommet gland
Complete device data (fitting + electronic module)	
Pipe diameter	1/2" to 16" (DN 15 to 400)
Measuring range	Coil transducer version Hall transducer version
	1.6 f/s to 32.8 f/s (0.5 m/s to 10 m/s) 1.0 f/s to 32.8 f/s (0.3 m/s to 10 m/s)
Medium temperature max.	with Fitting in Coil transducer version Hall transducer version
	PVC: 122°F (50°C) – PP: 176°F (80°C) – PVDF, Stainless steel, brass: 212°F (100°C) PVC: 122°F (50°C) – PP, PVDF, St.St., brass: 176°F (80°C)
Fluid pressure max.	145 PSI (PN10) (see pressure/temperature chart)
Viscosity	300 cSt. max., solid particles rate max. 1%
Accuracy	(see diagramm)
Teach-In	≤ ±0.5% of F.S.* (at 10 m/s) ¹⁾
Standard K-Factor	≤ ±(0.5% of F.S.* + 2.5% of Reading) ¹⁾
Linearity	≤ ±0.5% of F.S.* (at 10 m/s)
Repeatability	≤ 0.4% of Reading*
Electrical data	
Power supply	Standard signal Battery indicator/totalizer
	12–30 VDC; 115/230 VAC 9 VDC batteries, autonomy min. 3–4 years at 20°C (lithium batteries)
Current consumption with sensor	
Transmitter with relays	< 70 mA
Transmitter without relay	< 20 mA
Output	
Standard signal	
Signal current	4–20 mA (3-wire with relays; 2-wire without relays) max. load: 900 Ω at 30 V; 500 Ω at 24 V; 100 Ω at 15 V; 800 Ω with supply 230 VAC; Transistor open collector, NPN/PNP, 0...30 V; 100 mA, protected
Pulse	2 relays, freely programmable, 3A, 230 V
Relay (option)	None
Battery indicator / totalizer	None

* Under reference conditions i.e. measuring fluid=water, ambient and water temperature=20°C, applying the minimum inlet and outlet pipe straights, matched inside pipe dimensions.
 1) F.S.=Full scale (10 m/s)

DTS 1000094824 EN Version: A Status: RL (released | freigegeben | validé) printed: 09.02.2010

Installation

The 8025 flow rate transmitter can easily be installed into any Bürkert insertion fitting system (S020) by just fixing the main nut.

The minimum straight upstream (10xDN) and downstream (3xDN) distances must be observed. According to the pipe's design, necessary distances can be bigger or use a flow conditioner to obtain the best accuracy.

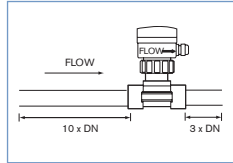

For more information, please refer to EN ISO 5167-1.

The flow rate indicator can be installed in either horizontal or vertical pipes.

Pressure and temperature ratings must be respected according to the selected fitting material.

The suitable pipe size is selected using diagram Flow/Velocity/DN.

The flow sensor is not designed for gas flow measurement.

Installation positions

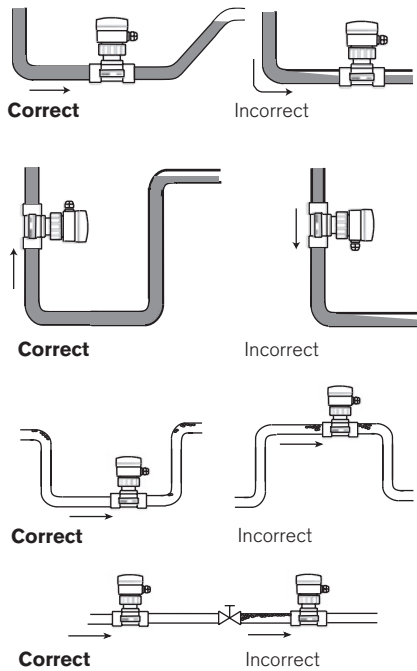

Pressure / temperature chart

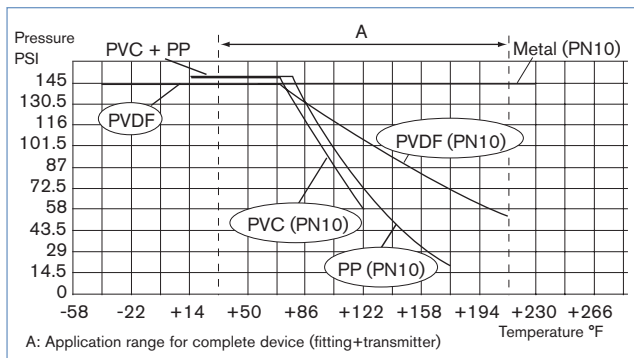

Selection of fitting / pipe size

Example:

- Specification of nominal flow: 10 m³/h
- Ideal flow velocity: 2...3 m/s
- For these specifications, the diagram indicates a pipe size of 1 1/2" (DN40)

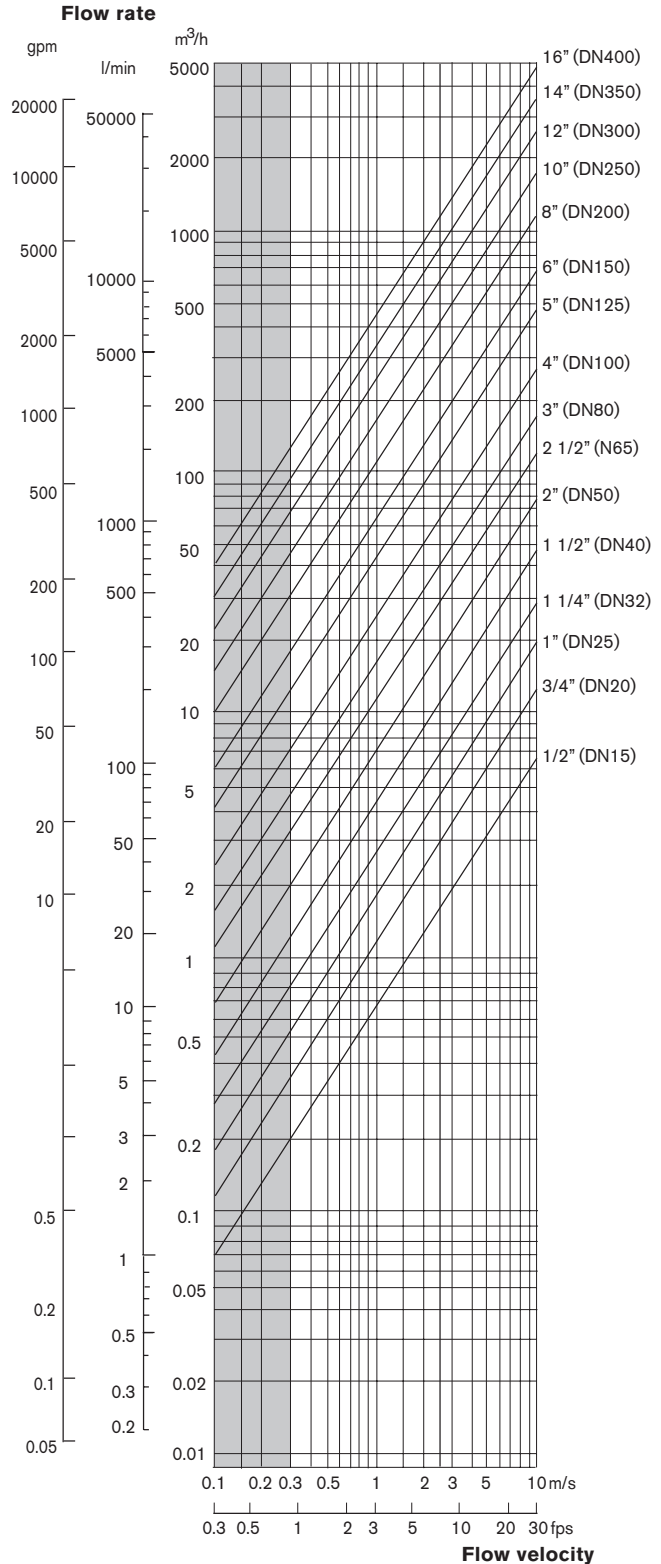

Dimensions [mm]

Compact version

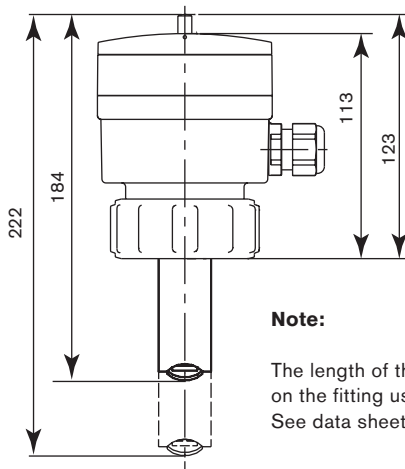
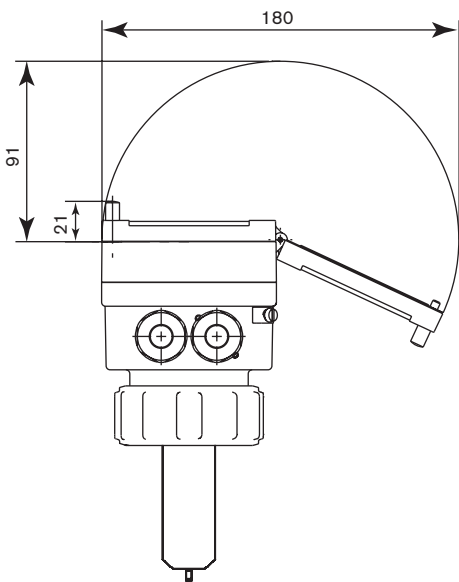

Note:

The length of the sensor finger is depends on the fitting used.
See data sheet Type S020.

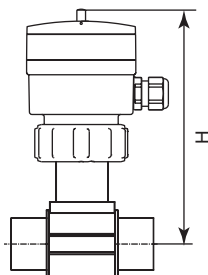
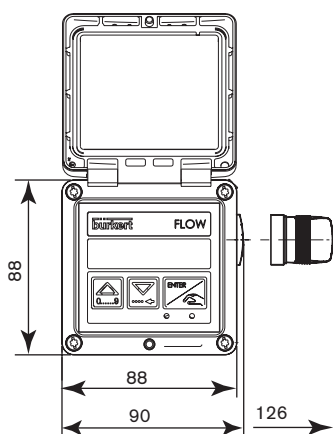
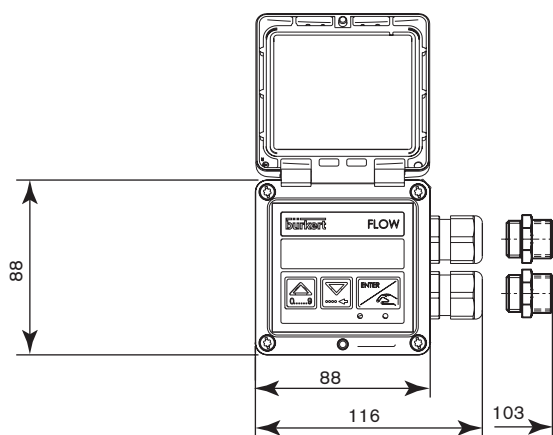

DN [mm]	H [mm]			
	T-Fitting	Saddle	Plastic spigot	St. St. spigot
15	186			
20	183			
25	183			
32	187			
40	191			187
50	197	221		192
65	197	220	202	196
80		224	207	203
100		229	214	213
110		225		
125		232		224
150		242	260	235
180		266		
200		278	281	256
250			299	316
300			304	335
350			324	347
400			338	

Insertion fitting dimensions [mm]

Internal thread
Stainless steel (316L - 1.4404)
or brass (CuZn39Pb2)

NPT
G
Rc

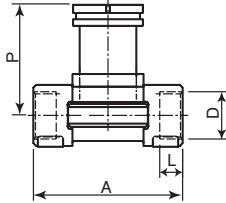

Note: short sensor version

Orifice [DN]	P [mm]	A [mm]	D	L [mm]
1/2" (15)	80.3	85.0	NPT 1/2	17.0
			G 1/2	16.0
			Rc 1/2	15.0
3/4" (20)	77.8	95.0	NPT 3/4	18.3
			G 3/4	17.0
			Rc 3/4	16.3
1" (25)	78.0	105.0	NPT 1	18.0
			G 1	23.5
			Rc 1	18.0
1 1/4" (32)	81.6	120.0	NPT 1 1/4	21.0
			G 1 1/4	23.5
			Rc 1 1/4	21.0
1 1/2" (40)	85.4	130.0	NPT 1 1/2	20.0
			G 1 1/2	23.5
			Rc 1 1/2	19.0
2" (50)	91.5	150.0	NPT 2	24.0
			G 2	27.5
			Rc 2	24.0

External thread
Stainless steel (316L - 1.4404)
or Brass (CuZn39Pb2)
or PVC (only DN 6 and 8)

G

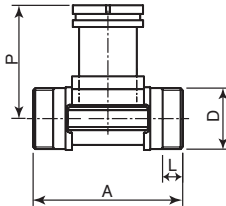

Note: short sensor version

Orifice [DN]	P [mm]	A [mm]	D	L [mm]
1/4" (6)	75.3	90.0	G 1/2	14.0
5/16" (8)	75.3	90.0	G 1/2	14.0
1/2" (15)	80.3	84.0	G 3/4	11.5
3/4" (20)	77.8	94.0	G 1	13.5
1" (25)	78.0	104.0	G 1 1/4	14.0
1 1/4" (32)	81.6	119.0	G 1 1/2	18.0
1 1/2" (40)	85.4	129.0	M 55 x 2	19.0
2" (50)	91.5	149.0	M 64 x 2	20.0

External thread
Stainless steel (316L - 1.4404)

SMS1145

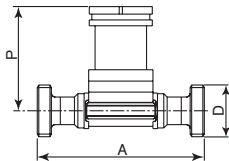

Note: short sensor version

Orifice [DN]	P [mm]	A [mm]	D
1" (25)	77.8	130	Rd40 x 1/6"
1 1/2" (40)	81.6	164	Rd60 x 1/6"
2" (50)	85.4	173	Rd70 x 1/6"

Insertion fitting dimensions [mm] (continued)

Welding ends
Stainless steel (316L - 1.4404)
BS 4825/ASME BPE
EN ISO 1127 / ISO 4200
SMS 3008

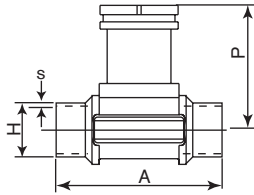

Note: short sensor version

Orifice [DN]	P [mm]	A [mm]	Standard	D [mm]	s [mm]
1/2" (15)	80.3	84.0	ASME BPE	-	-
	-	-	ISO 4200	21.30	1.60
	-	-	SMS 3008	-	-
3/4" (20)	83.3	84.0	ASME BPE	19.05	1.65
	77.8	94.0	ISO 4200	26.90	1.60
	83.3	84.0	SMS 3008	20.00	1.00
1" (25)	77.8	94.0	BS4825/ASME BPE	25.40	1.65
	78.0	104.0	ISO 4200	33.70	2.00
	77.8	94.0	SMS 3008	25.00	1.20
1 1/4" (32)	78.0	104.0	BS4825/ASME BPE	32.00	1.60
	81.6	119.0	ISO 4200	42.40	2.00
	78.0	104.0	SMS 3008	-	-
1 1/2" (40)	81.6	119.0	BS 4825	38.10	1.65
	85.4	129.0	ISO 4200	48.30	2.00
	81.6	119.0	SMS 3008	38.00	1.20
2" (50)	85.4	128.0	BS4825/ASME BPE	50.80	1.65
	91.5	149.0	ISO 4200	60.30	2.00
	85.4	128.0	SMS 3008	51.00	1.20
2 1/2" (65)	91.5	147.0	BS4825/ASME BPE	63.50	1.65
	-	-	ISO 4200	-	-
	91.5	147.0	SMS 3008	63.50	1.60

DTS 1000094824 EN Version: A Status: RL (released | freigegeben | validé) printed: 09.02.2010

Tri-Clamp®
Stainless steel
 (316L - 1.4404)
BS 4825/ASME BPE*
ISO (for pipe EN ISO 1127 / ISO 4200)
SMS 3017 / ISO 2852*

*Available with internal surface finish Ra=0.8µm

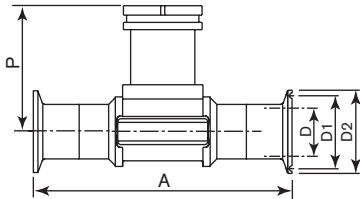

Note: short sensor version

Orifice [DN]	P [mm]	A [mm]	Standard	D2 [mm]	D1 [mm]	D [mm]
1/2" (15)	80.3	130	ASME BPE	-	-	-
	-	-	ISO (for pipe ISO 4200)	18.1	27.5	34.0
	-	-	SMS 3017/ISO 2852	-	-	-
3/4" (20)	77.8	150	ASME BPE	15.75	-	25.0
	80.3	-	ISO (for pipe ISO 4200)	23.7	43.5	50.5
	-	-	SMS 3017/ISO 2852	-	-	-
1" (25)	78.0	160	BS 4825/ASME BPE	22.1	43.5	50.5
	77.8	129.0	ISO (for pipe ISO 4200)	29.7	43.5	50.5
	-	-	SMS 3017/ISO 2852	22.6	43.5	50.5
1 1/4" (32)	81.6	180	BS 4825/ASME BPE	-	-	-
	-	-	ISO (for pipe ISO 4200)	38.4	43.5	50.5
	-	-	SMS 3017/ISO 2852	-	-	-
1 1/2" (40)	85.4	200	BS 4825/ASME BPE	34.8	43.5	50.5
	81.6	161.0	ISO (for pipe ISO 4200)	44.3	56.5	64.0
	-	-	SMS 3017/ISO 2852	35.6	43.5	50.5
2" (50)	91.5	230	BS 4825/ASME BPE	47.5	56.5	64.0
	85.4	192.0	ISO (for pipe ISO 4200)	55.1	70.5	77.5
	-	-	SMS 3017/ISO 2852	48.6	56.5	64.0
2 1/2" (65)	-	-	BS 4825/ASME BPE	60.2	70.5	77.5
	-	-	ISO (for pipe ISO 4200)	-	-	-
	91.5	216.0	SMS 3017/ISO 2852	60.3	70.5	77.5

Insertion fitting dimensions (continued)

Flange
Stainless steel (316L - 1.4404)
DIN 2633
ANSI B16-5-1988
JIS 10K

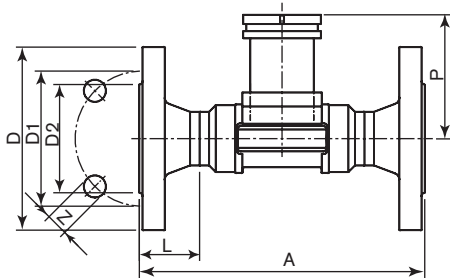

Note: short sensor version

Orifice	P	A			L	Z	D2	D1	D
[DN]	[mm]	DIN/ANSI	JIS	NORM	[mm]	[mm]	[mm]	[mm]	[mm]
1/2" (15)	80.3	130.0	152.0	ANSI DIN JIS	23.5	4x15.8 4x14.0 4x15.0	34.9 45.0 51.0	60.3 65.0 70.0	89.0 95.0 95.0
3/4" (20)	77.8	150.0	178.0	ANSI DIN JIS	28.5	4x15.8 4x14.0 4x15.0	42.9 58.0 56.0	69.8 75.0 75.0	99.0 105.0 100.0
1" (25)	78.0	160.0	216.0	ANSI DIN JIS	28.5	4x15.8 4x14.0 4x19.0	50.8 68.0 67.0	79.4 85.0 90.0	108.0 115.0 125.0
1 1/4" (32)	81.6	180.0	229.0	ANSI DIN JIS	31.0	4x15.8 4x18.0 4x19.0	63.5 78.0 76.0	88.9 100.0 100.0	117.0 140.0 135.0
1 1/2" (40)	85.4	200.0	241.0	ANSI DIN JIS	36.0	4x15.8 4x18.0 4x19.0	73.0 88.0 81.0	98.4 110.0 105.0	127.0 150.0 140.0
2" (50)	91.5	230.0	267.0	ANSI DIN JIS	41.0	4x15.8 4x18.0 4x19.0	92.1 102.0 96.0	120.6 125.0 120.0	152.0 165.0 155.0

True union nut with solvent or fusion spigot
PVC, PP, PVDF

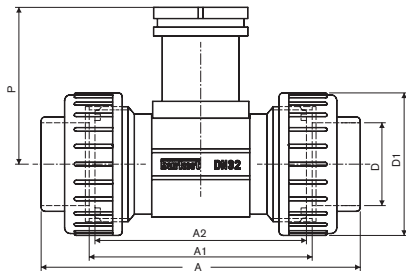

Note: short sensor version

Orifice	P	D1	A			D			A2	A1
[DN]	[mm]	[mm]	DIN	ANSI	JIS	(DIN)	(ANSI)	(JIS)	[mm]	[mm]
1/2" (15)	80.4	43	128	130.0	129	20	21.3	18.40	90	96
1/2" (15)*	81.4	74	148	-	-	20	-	-	110	116
3/4" (20)	77.8	53	144	145.6	145	25	26.7	26.45	100	106
3/4" (20)*	81.4	74	154	-	-	25	-	-	110	116
1" (25)	78.0	60	160	161.4	161	32	33.4	32.55	110	116
1" (25)*	81.4	74	160	-	-	32	-	-	110	116
1 1/4" (32)	81.4	74	168	170.0	169	40	42.2	38.60	110	116
1 1/2" (40)	85.2	83	188	190.2	190	50	48.3	48.70	120	127
2" (50)	91.5	103	212	213.6	213	63	60.3	60.80	130	136

* Analysis version fitting

Solvent or fusion spigot
PVC, PP, PVDF

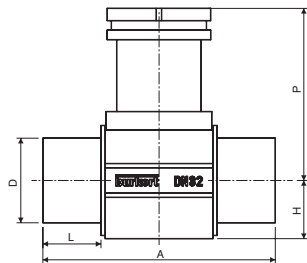

Note: short sensor version

Orifice	P	H	A		D			L	
[DN]	[mm]	[mm]	PVC	PP/PVDF	(DIN)	(ANSI)	(JIS)	PVC	PP/PVDF
1/2" (15)	80.4	17.5	90	85	20	21.3	18.40	16.5	14
3/4" (20)	77.8	17.5	100	92	25	26.7	26.45	20.0	16
1" (25)	78.0	21.5	110	95	32	33.4	32.55	23.0	18
1 1/4" (32)	81.4	27.5	110	100	40	42.2	38.60	27.5	20
1 1/2" (40)	85.2	31.5	120	106	50	48.3	48.70	30.0	23
2" (50)	91.5	39.5	130	110	63	60.3	60.80	37.0	27

Welding tab with radius
Stainless steel (316L - 1.4404)

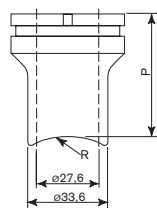

Note:
 Sensor version:
 - short for 2" (DN 50) - 8" (DN 200)
 - long for 10" (DN 250) - 14" (DN 350)

Orifice (DN)	P [mm]	R [mm]
2" (50)	56.55	30.15
2 1/2" (65)	54.52	36.65
3" (80)	53.07	44.45
4" (100)	50.71	57.15
5" (125)	48.24	70.65
6" (150)	45.73	84.15
8" (200)	41.01	109.55
10" (250)	73.64	136.55
12" (300)	67.83	161.95
14" (350)	63.94	177.80

Insertion fitting dimensions

Fusion spigot
PE, PP, PVDF

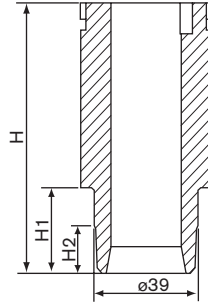

Note:

Sensor version:

- short for 2 1/2" (DN 65) – 4" (DN 100)
- long for 6" (DN 150) – 16" (DN 400)

DIA. [DN]	H [mm]	PE		PP		PVDF	
		H1 [mm]	H2 [mm]	H1 [mm]	H2 [mm]	H1 [mm]	H2 [mm]
2 1/2" (65)	72.5	13.0	---	13.0	---	10.4	---
3" (80)	72.5	15.6	---	15.6	---	12.5	---
4" (100)	72.5	19.0	5.0	19.0	5	15.2	6
6" (150)	102.0	27.7	10.0	27.7	10	---	---
8" (200)	102.0	38.9	16.0	38.9	16	---	---
10" (250)	102.0	48.4	21.0	48.4	21	---	---
12" (300)	102.0	61.3	28.0	61.3	28	---	---
14" (350)	102.0	61.3	28.0	61.3	28	---	---
16" (400)	102.0	69.1	31.5	---	---	---	---

Screw-on PVC, PP, PE
DN 100 to 400

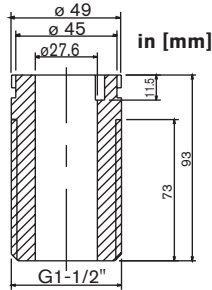

Note: long sensor version

Saddle- PVC

Body material: PVC, Seal material: BUNA

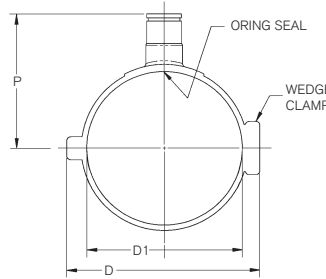

DIA.	D[mm]	P[mm]	D1[mm]
2 1/2" (65)	129	115.0	75.0
3" (80)	144	119.0	90.0
4" (100)	163	107.0	114.0
6" (150)	219	168.0	168.0
8" (200)	272	191.0	218.0

Note: short sensor version required up to 4". Long sensor version required 6"-8"

Saddle – carbon steel

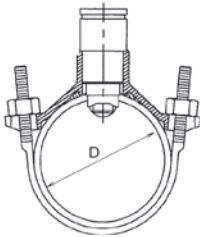

Item no.	Pipe size [in.]	D [in.]
98146031	2"	2.35 – 2.56
98146024	3"	2.97 – 3.54
98146025	4"	4.14 – 4.80
98146026	6"	5.94 – 6.90
98146027	8"	7.69 – 9.05
98146028	10"	10.64 – 12.12
98146029	12"	12.62 – 14.32
98109612	14"	14.73 – 15.65

Note: Vertical mounting is recommended for best overall performance. Mount at a maximum of 45° when air bubbles are present. Do not mount on the bottom of the pipe when sediments are present. D = I.D. of the Saddle.

Weldolet – carbon steel

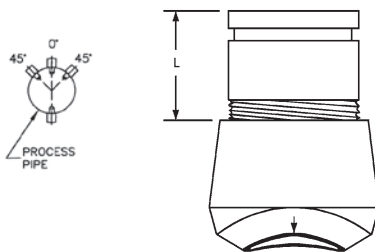

Pipe Size [in.]	L [in.]
2"	2.61
2 1/2"	2.53
3"	2.47
4"	2.38
6"	2.19
8"	2.00
10"	1.80
12"	1.62
14"	1.50

Note: Vertical mounting is recommended for best overall performance. Mount at a maximum of 45° when air bubbles are present. Do not mount on the bottom of the pipe when sediments are present.

Remote universal transmitter Type 8025 (for connection to Burkert sensor or other sensor types...)

The remote universal transmitter

is available in two versions:

– Panel-mounted



– Wall-mounted



This flow transmitter can be associated with:

- a separate flow sensor 8020, 8030 with sinus or pulse signal (coil or hall transducer)
- or
- another flow sensor available from Burkert or the market.

General data	
Compatibility	Burkert flow sensor with frequency output (8020, 8030, 8030HT, 8040, 8041, 8031, 8070, 8071) and other sensors with compatible electrical data.
Materials	Housing, cover: PC (panel-mounted version); ABS (wall-mounted version) Front panel foil: Polyester Screws: Stainless Steel Cable plug / gland: PA
Electrical connections	Terminals (panel-mounted version) or terminals via gland (wall-mounted version)
Electrical data	
Power supply	Panel-mounted version: 12–30 VDC Wall-mounted version: 12–30 VDC; 115/230 VAC
Current consumption without sensor	Transmitter with relays: 100 mA Transmitter without relay: 60 mA
Sensor input	Frequency range: 0.5 Hz or 2.5 Hz up to 1400 Hz Open collector NPN (with 470 Ω or 2.2 kΩ resistance) or PNP, Coil, TTL, CMOS (with 100 kΩ resistance)
Sensor output	Voltage supply: 13...30 VDC; +12 V or +27V (with a 115/230V powered transmitter) Current consumption: max. current available from transmitter: 25 mA (version 115/230 VAC) 100 mA (version 13-30 VDC)
Output Transmitter	Signal current: 4–20 mA (3-wire with relays; 2-wire without relay) max. load: 1300 Ω at 30 V; 1000 Ω at 24 V; 550 Ω at 15 V; 400 Ω at 13 V; 1200 Ω at 115/230 VAC Pulse: Transistor open collector, NPN/PNP, 0...30 V; 100 mA, protected Relay (option): 2 relays, programmable, 3A, 230 V
Standards and approvals	
Protection class	IP65 (panel-mounted and wall-mounted version) IP20 (panel-mounted version, inside the cabinet)
Approval	CSA, UL listed

Dimensions [mm]

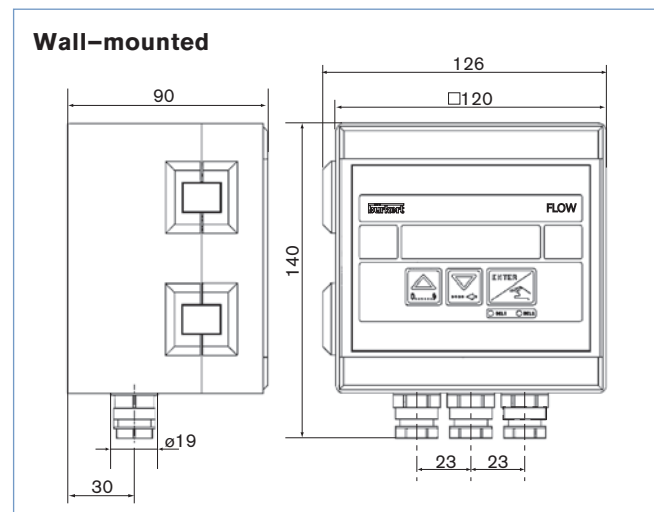
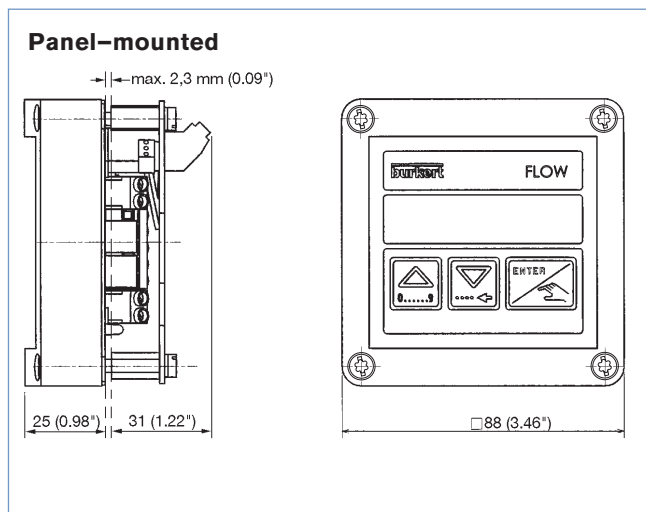

Remote transmitter Type 8025 (for connection to compact Burkert sensors)

The remote transmitter

is available in two versions:

– Panel-mounted



– Wall-mounted



A separate compact flow sensor 8020, 8030 or 8070 with sinus or pulse signal (coil or hall transducer) from Burkert can be associated with this flow transmitter.

General data	
Compatibility	Burkert flow sensor with frequency output 8020, 8030 or 8070 (sinus or pulse low power version).
Materials	Housing, cover Front panel foil Screws Cable plug / gland PC (panel-mounted version); ABS (wall-mounted version) Polyester Stainless Steel PA
Electrical connections	Terminals (panel-mounted version) or terminals via gland (wal-mounted version)
Electrical data	
Power supply	Transmitter Battery indicator/totalizer
	12–30 VDC; 115/230 VAC 9 VDC batteries, autonomy min. 3/4 years at 68°F (20°C) (lithium batteries)
Current consumption without sensor	
with relays	≤ 70 mA
without relay	≤ 20 mA
Sensor input	
Frequency range	2.5 Hz up to 300 Hz
Transmitter	Sinus or Pulse low power (open collector NPN)
Battery indicator/totalizer	Sinus only
Sensor output	
Voltage supply	12–36 VDC (Transmitter); None (Indicator / Totalizer)
Current consumption	max. current available from transmitter: 1 mA
Output	
Transmitter	
Signal current	4–20 mA (3-wire with relays; 2-wire without relay) max. load: 900 Ω at 30 V; 500 Ω at 24 V; 100 Ω at 15 V; 800 Ω with supply 230 VAC; Transistor open collector, NPN/PNP, 0...30 V; 100 mA, protected
Pulse	2 relays, programmable, 3A, 230 V
Relay (option)	None
Battery indicator/totalizer	None
Standards and approvals	
Protection class	IP65 (panel-mounted and wall-mounted version) IP20 (panel-mounted version, inside the cabinet)
Agreements	CE, CSA, UL listed

Dimensions [mm]

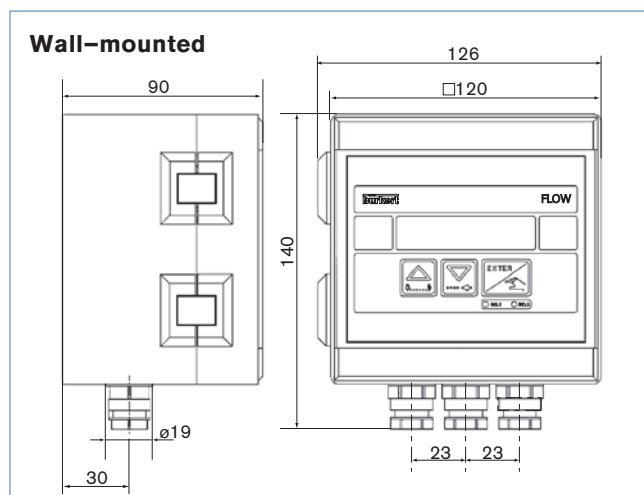
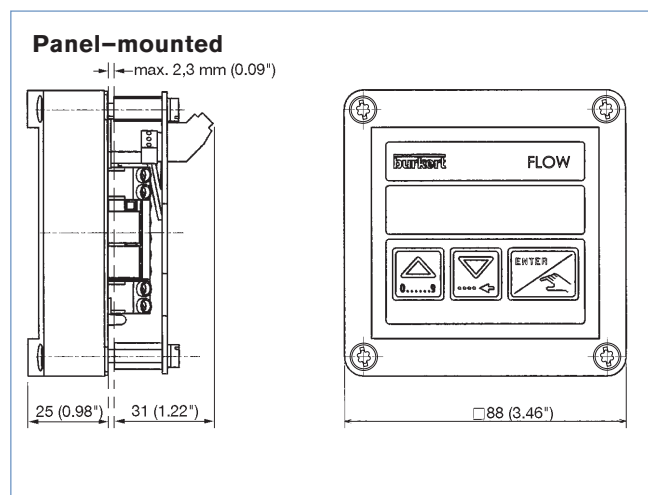

Ordering chart for compact transmitter Type 8025

Compact flow transmitter or indicator / totalizer with integrated paddle-wheel sensor

A compact flow transmitter or indicator / totalizer Type 8025 consists of:

- an insertion flow transmitter or indicator / totalizer 8025
- an insertion fitting S020 (1.2" – 16") (Refer to corresponding datasheet - has to be ordered separately)

Version	Specifications	Voltage supply	Output	Relays	Sensor version*	Electrical connection **	Item no.	
Compact	Standard output signal transmitter 2 totalizers	12-30 VDC	4-20 mA (2 wires) + pulse	None	Hall, short	cable grommet DIN plug	418 762	
						2 cable grommet glands	418802	
					Hall, long	cable grommet DIN plug	418 763	
						2 cable grommet glands	418 803	
					Coil, short	cable grommet DIN plug	418 764	
						2 cable grommet glands	418 804	
					Coil, long	cable grommet DIN plug	418 765	
						2 cable grommet glands	418 805	
					4-20 mA (2 wires) + pulse	Hall, short	2 cable grommet glands	418 778
							Hall, long	2 cable grommet glands
		Coil, short	2 cable grommet glands	418 780				
		Coil, long	2 cable grommet glands	418 781				
		115-230 VAC	4-20 mA (2 wires) + pulse	Hall, short	2 cable grommet glands	418 423		
					Hall, long	2 cable grommet glands	418 424	
				Coil, short	2 cable grommet glands	418 425		
				Coil, long	2 cable grommet glands	418 426		
			4-20 mA (3 wires) + pulse	Hall, short	2 cable grommet glands	418 431		
					Hall, long	2 cable grommet glands	418 432	
				Coil, short	2 cable grommet glands	418 433		
				Coil, long	2 cable grommet glands	418 434		
Indicator, 2 totalizers	9 VDC Batteries	---	None	Coil, short	None	418 403		
				Coil, long	None	418 405		

* Note:

FKM gasket is standard; 1 Kit including a black EPDM gasket for the sensor, a plug for an M20x1.5 cable gland, a 2x6 mm multiway seal and a mounting instruction sheet is supplied with each transmitter.

** See 8025 accessories for 1/2" conduit kit or ring

Ordering chart for remote universal transmitter Type 8025

Remote universal transmitter Type 8025 low flow (panel- or wall-mounted)

A complete remote universal flow transmitter Type 8025 consists of:
 - a remote universal transmitter Type 8025 (wall-mounted or panel-mounted)
 - a Burkert flow sensor* or any (has to be ordered separately)

Version	Specifications	Voltage supply	Output	Relays	Sensor version*	Electrical connection	Item no.
Panel-mounted	8025 Low Flow Transmitter 2 totalizers	12-30 VDC	4-20 mA (3 wires) + pulse	None	see note	Terminal strip	419 538
				2	see note	Terminal strip	419 537
Wall-mounted	8025 Low Flow Transmitter 2 totalizers	12-30 VDC	4-20 mA (3 wires) + pulse	None	see note	3 cable grommet glands	419 541
				2	see note	3 cable grommet glands	419 540
		115-230 VAC	4-20 mA (3 wires) + pulse	None	see note	3 cable grommet glands	419 544
				2	see note	3 cable grommet glands	419 543

* See the chart about compatible and recommended interconnection possibilities with Burkert sensors.

Ordering chart for remote transmitter Type 8025

Remote transmitter, batch controller indicator / totalizer Type 8025 (for panel or wall mounting) for connection to Burkert sensor only

A complete remote transmitter, indicator / totalizer Type 8025 consists of:
 - a remote transmitter Type 8025 (wall-mounted or panel-mounted)
 - an insertion flow sensor Type 8020 or INLINE flow sensor SE30 (pulse or sinus version) (Refer to corresponding datasheet -has to be ordered separately)
 - an insertion fitting S020 (DN15 -DN 400) or INLINE fitting S030 (DN6 - DN65) (Refer to corresponding datasheet -has to be ordered separately)

Version	Specifications	Voltage supply	Output	Relays	Sensor version*	Electrical connection	Item no.	
Panel-mounted	Transmitter 2 totalizers	12-30 VDC	4-20 mA (2 wires) + pulse	None	8020/8030	Terminal strip	418 992	
	Transmitter 2 totalizers, agreements CSA, UL listed	12-30 VDC	4-20 mA (2 wires) + pulse	None	8020/8030	Terminal strip	552 725	
			4-20 mA (3 wires) + pulse	2	8020/8030	Terminal strip	552 726	
Batch controller 2 totalizers, 1 flow	12-30 VDC			2	8020/8030	Terminal strip	419 536 P	
Wall-mounted	Transmitter 2 totalizers	12-30 VDC	4-20 mA (2 wires) + pulse	None	8020/8030	3 cable glands	418 397	
		115-230 VAC	4-20 mA (2 wires) + pulse	None	8020/8030	3 cable glands	418 400	
	Indicator, 2 totalizers	9 VDC Batteries	None	None	8020/8030	1 cable gland	418 402	
	Batch controller 2 totalizers, 1 flow	12-30 VDC			2	8020/8030	3 cable glands	433 740 D
		115-230 VAC			2		3 cable glands	433 741 S

* See the chart about compatible and recommended interconnection possibilities with Burkert sensors.

Ordering chart for accessories for transmitter Type 8025 (has to be ordered separately)

Specifications	Item No.
1/2" NPT conduit ring for converting cable grommet DIN plug	014 132 F
1/2" NPT conduit kit for converting cable grommet gland entry	551 782 S
Set with 2 cable glands M20x1.5 + 2 neoprene flat seals for cable gland or plug + 2 screw-plugs M20x1.5 + 2 multiway seals 2x6 mm	449 755
Set with 1 stopper for unused cable gland M20x1.5 + 1 multiway seal 2x6 mm for cable gland or plug + 1 black EPDM gasket for the sensor + 1 mounting instruction sheet	551 775
Ring	619 205
PC- Nut	619 204
Set with 1 green FKM + 1 black EPDM gaskets	552 111
Cable plug Type 2509 - UR and UL approval	162 673

Ordering chart for insertion fitting S020

Brass – T-fitting

Port connection	Specification		Item no. / Orifice						
	Seal	Standards	1/2" (DN 15)	3/4" (DN 20)	1" (DN 25)	1 1/4" (DN 32)	1 1/2" (DN 40)	2" (DN 50)	2 1/2" (DN 65)
Internal thread	FKM	NPT	428 718	428 719	428 720	428 721	428 722	428 723	---
		G	428 712	428 713	428 714	428 715	428 716	428 717	---
		Rc (ISO7)	428 724	428 725	428 726	428 727	428 728	428 729	---
External thread	FKM	G	428 730	428 731	428 732	428 733	428 734	428 735	---

Stainless steel – T-fitting

Port connection	Specification		Item no. / Orifice						
	Seal	Standards	1/2" (DN 15)	3/4" (DN 20)	1" (DN 25)	1 1/4" (DN 32)	1 1/2" (DN 40)	2" (DN 50)	2 1/2" (DN 65)
Internal thread	FKM	NPT	428 742	428 743	428 744	428 745	428 746	428 747	---
		G	428 736	428 737	428 738	428 739	428 740	428 741	---
		Rc (ISO7)	428 748	428 749	428 750	428 751	428 753	428 754	---
External thread	FKM	G	428 754	428 755	428 756	428 757	428 758	428 759	---
	EPDM	SMS 1145	---	---	443 317	---	443 318	443 319	---
Weld ends	FKM	EN ISO 1127/ISO 4200	---	428 760	428 761	428 762	428 763	428 764	428 765
	EPDM	BS4825 / ASME BPE	---	443 734	443 735	443 736	443 942	443 943	443 944
		SMS 3008	---	---	443 309	---	443 310	443 311	443 312
Tri-Clamp®	FKM	EN ISO 1127/ISO 4200	---	428 766	428 767	428 768	428 769	428 770	428 771
	EPDM	BS4825/ASME BPE	---	443 965	443 966	---	443 967	443 968	443 969
		SMS3017/ISO2852	---	---	443 313	---	443 314	443 315	443 316
		BS4825/ASME BPE* SMS3017/ISO2852*	---	443 970 ---	443 971 ---	---	443 972 443 958	443 973 443 959	443 974 443 960
Flange	FKM	ANSI B16-5-1988	428 778	428 779	428 780	428 781	428 782	428 783	---
		DIN 2633	428 772	428 773	428 774	428 775	428 776	428 777	---
		JIS 10K	431 053	431 054	431 055	431 056	431 057	431 058	---

* internal surface finish Ra = 0.8 µm

Stainless steel – welding tab with radius

Specification	2" (DN 50)	2 1/2" (DN 65)	3" (DN 80)	4" (DN 100)	5" (DN 125)	6" (DN 150)	8" (DN 200)	10" (DN 250)	12" (DN 300)	14" (DN 350)
Weld tabs	418 111	418 112	418 113	418 114	418 115	418 116	418 117	418 756	720 070	416 637

Carbon steel saddles – (requires long finger sensor)

Specification	2" (DN 50)	3" (DN 80)	4" (DN 100)	5" (DN 125)	6" (DN 150)	8" (DN 200)	10" (DN 250)	12" (DN 300)	14" (DN 350)
	98146031	98146024	98146025	---	98146026	98146027	98146028	98146029	98109612

Carbon steel weldolet – (requires long finger sensor)

Specification	2" (DN 50)	2 1/2" (DN 65)	3" (DN 80)	4" (DN 100)	5" (DN 125)	6" (DN 150)	8" (DN 200)	10" (DN 250)	12" (DN 300)
	98146032	98146034	98146035	98146020	---	98146021	98146022	98146023	98146036

PVC – T-fitting

Port connection	Specification		Item no. / Orifice					
	Seal	Standards	1/2" (DN 15)	3/4" (DN 20)	1" (DN 25)	1 1/4" (DN 32)	1 1/2" (DN 40)	2" (DN 50)
True union - solvent spigot	FKM	ASTM	428 682	428 683	428 684	428 685	428 686	428 687
		ISO	428 670	428 671	428 672	428 673	428 674	428 675
		JIS	429 078	429 079	429 080	429 081	429 082	429 083
Solvent ends	FKM	ISO	428 676	428 677	428 678	428 679	428 680	428 681
For Analysis: True union- solvent spigot	FKM	ISO	430 837	430 838	460 839	428 673	428 674	4428 675

Ordering chart for insertion fitting S020

PVC saddle – (long finger required for 6" & 8" saddle)

Specification	Item no. / Orifice				
	2" (DN 50)	3" (DN 80)	4" (DN 100)	6" (DN 150)	8" (DN 200)
	413 469 W	413 470 T	98146019	98146017	98146030

PVC – Screw-on fitting

Specification	Item no. / Orifice									
	2 1/2" (DN 65)	3" (DN 80)	4" (DN 100)	5" (DN 125)	6" (DN 150)	8" (DN 200)	10" (DN 250)	12" (DN 300)	14" (DN 350)	16" (DN 400)
	---	---	418 170	418 170	418 170	418 170	418 170	418 170	418 170	418 170

PP – T-fitting

Port connection	Specification			Item no. / Orifice					
	Seal	Standards		9/16" (DN 6)	3/4" (DN 20)	1" (DN 25)	1 1/4" (DN 32)	1 1/2" (DN 40)	2" (DN 50)
True union - solvent spigot	FKM	ISO		428 688	428 689	428 690	428 691	428 692	428 693
Solvent ends	FKM	ISO		428 694	428 695	428 696	428 697	428 698	428 699
For Analysis: True union- solvent spigot	FKM	ISO		430 840	430 841	460 842	428 691	428 692	428 693

PP – Fusion spigot or Screw-on fitting

Specification	Item no. / Orifice									
	2 1/2" (DN 65)	3" (DN 80)	4" (DN 100)	5" (DN 125)	6" (DN 150)	8" (DN 200)	10" (DN 250)	12" (DN 300)	14" (DN 350)	16" (DN 400)
Fusion spigot	418 650	418 651	418 652	---	418 653	418 654	418 655	418 656	418 657	---
Screw-on	---	---	436 488	436 488	436 488	436 488	436 488	436 488	436 488	436 488

PVDF – T-fitting

Port connection	Specification			Item no. / Orifice					
	Seal	Standards		3/4" (DN 20)	1" (DN 25)	1 1/4" (DN 32)	1 1/2" (DN 40)	2" (DN 50)	2 1/2" (DN 65)
True union - solvent spigot	FKM	ISO		428 700	428 701	428 702	428 703	428 704	428 705
Solvent ends	FKM	ISO		428 706	428 707	428 708	428 709	428 710	428 711
For Analysis: True union- solvent spigot	FKM	ISO		430 843	430 844	460 845	428 703	428 704	428 705

PVDF – Fusion spigot or Screw-on fitting

Specification	Item no. / Orifice									
	2 1/2" (DN 65)	3" (DN 80)	4" (DN 100)	5" (DN 125)	6" (DN 150)	8" (DN 200)	10" (DN 250)	12" (DN 300)	14" (DN 350)	16" (DN 400)
Fusion spigot	418 658	418 659	418 660	---	---	---	---	---	---	---

PE – Fusion spigot or Screw-on fitting

Specification	Item no. / Orifice									
	2 1/2" (DN 65)	3" (DN 80)	4" (DN 100)	5" (DN 125)	6" (DN 150)	8" (DN 200)	10" (DN 250)	12" (DN 300)	14" (DN 350)	16" (DN 400)
Fusion spigot	418 642	418 643	418 644	---	418 645	418 646	418 647	418 648	418 649	418 598
Screw-on	---	---	436 489	436 489	436 489	436 489	436 489	436 489	436 489	436 489

DTS 1000094824 EN Version: A Status: RL (released | freigegeben | validé) printed: 09.02.2010

Interconnection with other Burkert products

Sensor Type	Remote universal transmitter		Transmitter version		Battery indicator / totalizer - Wall
	Panel	Wall	Remote transmitter Panel	Remote transmitter Wall	
8020 – Frequency output with Hall (pulse) signal (open collector, NPN, PNP) – (short or long)	X	X	-	-	-
8020 – Frequency output with low power Hall (pulse) signal (open collector, NPN) – (short or long)	X	X	X	X	-
8020 – Frequency output with coil (sinusoidal) signal – (short or long)	X	X	X	X	X
8030/8070 – Frequency output with Hall (pulse) signal (open collector, NPN, PNP) – (short or long)	X	X	-	-	-
8030/8070 – Frequency output with low power Hall (pulse) signal (open collector, NPN) – (short or long)	X	X	X	X	-
8030 – Frequency output with coil (sinusoidal) signal – (short or long)	X	X	X	X	X
8030 High temperature – Frequency output with Hall (pulse) signal (open collector, NPN, PNP)	X	X	-	-	-
8030 High temperature – Frequency output with coil signal	X	X	-	-	X
8031 – Frequency output with pulse signal (NPN)	X	X	-	-	-
8040 – Frequency output with pulse signal (NPN)	X	X ¹⁾	-	-	-
8041 – Frequency output with pulse signal (NPN)	X	X ¹⁾	-	-	-
8071 – Frequency output with pulse signal (NPN)	X	X	-	-	-

X = compatible or recommended interconnection possibilities.

¹⁾ except ID# 419543

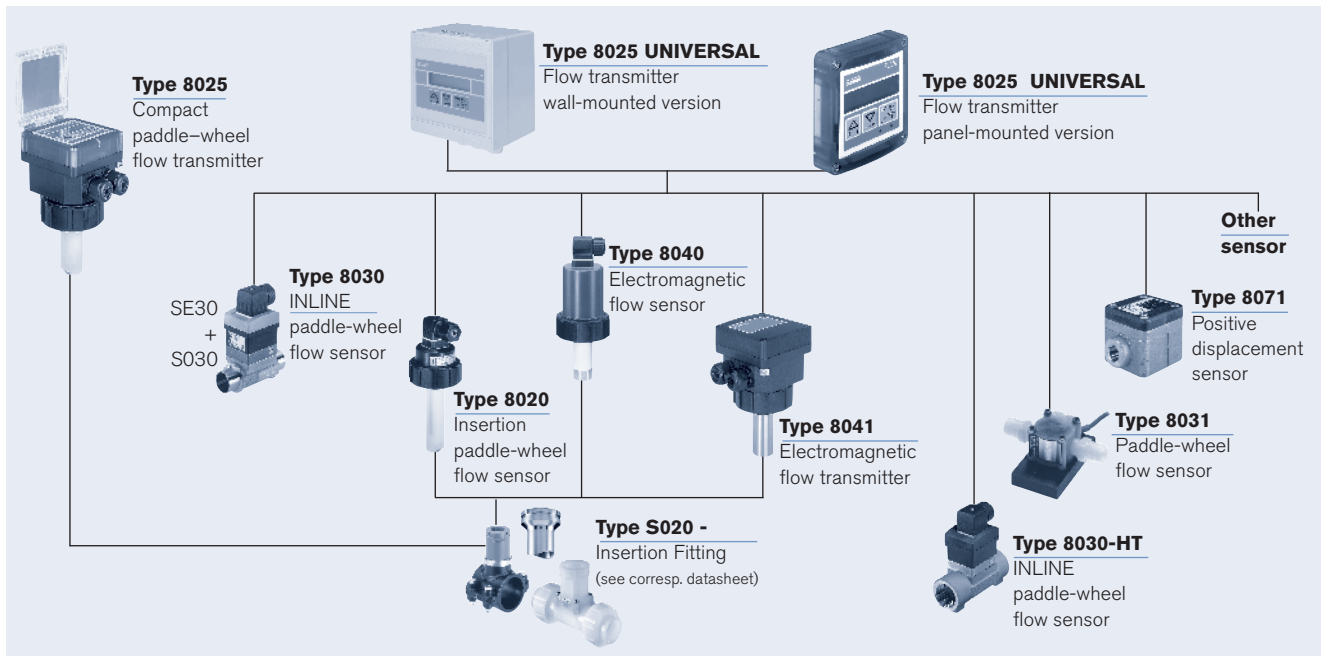

Available Fitting DN	T-fitting S020	1/2" (DN 15)		2 1/2" (DN65)	
		Short sensor			
Welding tab S020		2" (DN50)		8" (DN200) 14" (DN350)	
		Short sensor		Long sensor	
Fusion spigot S020		2 1/2" (DN65)		4" (DN100) 16" (DN400)	
		Short sensor		Long sensor	
Screw-on S020		4" (DN100)		16" (DN400)	
		Long sensor			
Saddle S020		2" (DN50)		8" (DN200)	
		Long sensor			

In case of special application conditions, please consult for advice.

We reserve the right to make technical changes without notice.

0911/5_US-en